

# Power Block 2000

One Platform, Infinite Possibilities

Site Design Guide for Europe



# IMPORTANT SAFETY INSTRUCTIONS

## SAVE THESE INSTRUCTIONS

This manual contains important instructions for ChargePoint® products that shall be followed during installation, operation and maintenance of each product.

### WARNING:



1. **Read and follow all warnings and instructions before servicing, installing, or operating the ChargePoint® product.** Install and operate only as instructed. Failure to do so may lead to death, injury, or property damage, and will void the Limited Warranty.
2. **ChargePoint recommends that installation, commissioning, and break-fix services be performed by a licensed electrician who is also a ChargePoint-certified technician.** These systems operate at high voltage, and without strict adherence to safety protocols, proper protective equipment, and ChargePoint technical guides, there is significant risk to people, equipment, and the environment. Please ensure full compliance with all applicable local and national buildings, electrical, and safety codes.
3. **Always ground the ChargePoint product.** A touch current of >3.5 mA AC RMS is possible in case of a fault condition of loss of electrical continuity of the earthing conductor. Failure to ground the product can lead to risk of electric shock. The product must be connected to a grounded, metal, permanent wiring system, or an equipment grounding conductor shall be run with circuit conductors and connected to the equipment grounding terminal or lead on the Electric Vehicle Supply Equipment (EVSE). Connections to the EVSE shall comply with all applicable codes and ordinances.
4. **Install the ChargePoint product using a ChargePoint-approved method.** Failure to install on a surface that can support the full weight of the product can result in death, personal injury, or property damage. Inspect the product for proper installation before use.
5. **The product is not suitable for use in Class 1 hazardous locations, such as near flammable, explosive, or combustible vapors or gases.**
6. **Supervise children near this device.**
7. **Do not put fingers into the electric vehicle connector or connector adapter. Do not touch fingers to charging rails.**
8. **Do not use this product if any cable is frayed, has broken insulation, or shows any other signs of damage.**
9. **Do not use this product if the enclosure, the flexible output cable, the vehicle inlet, the electric vehicle connector, or the electric vehicle connector adapter is broken, cracked, open, or shows any other signs of damage. Do not use this product if internal parts are accessible, including wiring.**
10. **Wire and wire terminal information are provided in the ChargePoint product Site Design Guide and Installation Guide.**

11. **Torques for installation of wire terminals are provided in the ChargePoint product Installation Guide.**
12. **The ChargePoint product maximum operating temperature is 50 °C (122 °F).**
13. **Do not use an electric vehicle connector adapter with any charger or EV that is capable of exceeding the adapter's rated voltage of current capacity. Some EVs and EVSE combinations are capable of multiple voltages or limited durations of current overloading designed for normal EVSE-to-EV connections. Use of an electric vehicle connector adapter in these situations could result in unsafe conditions such as fire, burns, or exposure of high voltage.**



**IMPORTANT:** Under no circumstances will compliance with the information in a ChargePoint guide such as this one relieve the user of the responsibility to comply with all applicable codes and safety standards. This document describes approved procedures. If it is not possible to perform the procedures as indicated, contact ChargePoint. ChargePoint is not responsible for any damages that may result from custom installations or procedures not described in this document or that fail to adhere to ChargePoint recommendations.

## Warranty Implication



**IMPORTANT:** Please be advised that all installation, commissioning, and break-fix services must be performed by a ChargePoint-certified technician. Engaging non-certified personnel for these services will result in warranty implications, as doing so constitutes a breach of policy.

## Support Services

<https://www.chargepoint.com/legal/support-services>

For more information about ChargePoint's training and certification program, visit <https://www.chargepoint.com/partners/training-certification>

## Product Disposal

To comply with Directive 2012/19/EU of the European Parliament and of the Council of 4 July 2012 on waste electrical and electronic equipment (WEEE), devices marked with this symbol may not be disposed of as part of unsorted domestic waste inside the European Union. Enquire with local authorities regarding proper disposal. Product materials are recyclable as marked.



## Document Accuracy

The specifications and other information in this document were verified to be accurate and complete at the time of its publication. However, due to ongoing product improvement, this information is subject to change at any time without prior notice. For the latest information, see our documentation online at [ChargePoint Product Reference Documentation](#).

## Copyright and Trademarks

©2013-2026 ChargePoint, Inc. All rights reserved. This material is protected by the copyright laws of the United States and other countries. It may not be modified, reproduced, or distributed without the prior, express written consent of ChargePoint, Inc. ChargePoint and the ChargePoint logo are trademarks of ChargePoint, Inc., registered in the United States and other countries, and cannot be used without the prior written consent of ChargePoint.

## Symbols

This guide and product use the following symbols:



**DANGER:** Risk of electric shock



**WARNING:** Risk of personal harm or death



**CAUTION:** Risk of equipment or property damage



**IMPORTANT:** Critical detail that must be followed to achieve intended results



**NOTE:** Important contextual details or procedural clarifications



**REINSTALL NOTE:** Essential instructions to follow when reinstalling a part or component



Read the manual for instructions



Ground/protective earth

## Illustrations Used in This Document

The illustrations used in this document are for demonstration purposes only and may not be an exact representation of the product. However, unless otherwise specified, the underlying instructions are accurate for the product.

# Contents

- IMPORTANT SAFETY INSTRUCTIONS ..... i
- Revision History ..... v
  
- 1 Introduction ..... 1**
  - About This Guide ..... 1
  - Power Block 2000 Overview ..... 1
  - Product Guides ..... 7
  - Questions ..... 7
  
- 2 Site Planning and Placement ..... 8**
  - Initial Site Guidelines ..... 8
  - Plan for Future Charging Capacity ..... 8
  - System Placement ..... 9
  
- 3 Civil and Mechanical Design ..... 10**
  - Dimensions ..... 10
  - Weights ..... 13
  - Mount Specifications ..... 14
  - Drainage ..... 19
  - Flood Plane ..... 19
  - Clearances ..... 20
  - Bollards ..... 24
  - Ventilation ..... 24
  - Signage ..... 25
  
- 4 Electrical Design ..... 26**
  - Electrical Supply Requirements ..... 26
  - Grounding Requirements ..... 28
  - Soft Shutdown ..... 29
  - Safety Hub ..... 29
  - Wiring and Conduit Requirements ..... 30
  
- 5 Connectivity ..... 39**
  - Signal Strength and Quality ..... 39
  - Repeaters ..... 41

# Revision History

This page provides a summary of revisions made, listing the month and year of each update along with a brief description of the changes made.

Month & Year	Description
Apr 2026	Early access draft, initial release.

# Introduction 1

This section defines the purpose of this guide and provides an introduction to the ChargePoint® Power Block 2000.

## About This Guide

This guide provides guidelines and best practices for designing project sites that will host the ChargePoint Power Block 2000. It covers electrical infrastructure requirements, capacity planning, conduit and concrete work, site layout considerations, and cellular signal requirements needed to prepare a site for installation.

This guide is intended for site designers, electrical engineers, project planners, architects, and construction professionals responsible for preparing a site for Power Block 2000 deployment.



**IMPORTANT:** You must be a licensed electrician and complete online training to become a ChargePoint certified installer. If you do not complete training, you cannot access the ChargePoint network to complete installation. Find online training at: <https://www.chargepoint.com/partners/training-certification>. If the charging station is not installed by a ChargePoint certified installer, using a ChargePoint approved method, it is not covered under warranty and ChargePoint is not responsible for any malfunctions.

## Power Block 2000 Overview

Power Block 2000 is a product within the ChargePoint Express DC fast charging platform. Power Block 2000 is a power cabinet, responsible for AC grid connection, power conversion, and DC power distribution to downstream EVSEs such as external Power Link charging dispensers.

For information on Power Link charging dispensers and other EVSEs in the ChargePoint Express platform, refer to the Express platform documents at [ChargePoint Product Reference Documentation](#).

## Exterior Parts

The following shows an exterior view of a single-cabinet Power Block 2000:

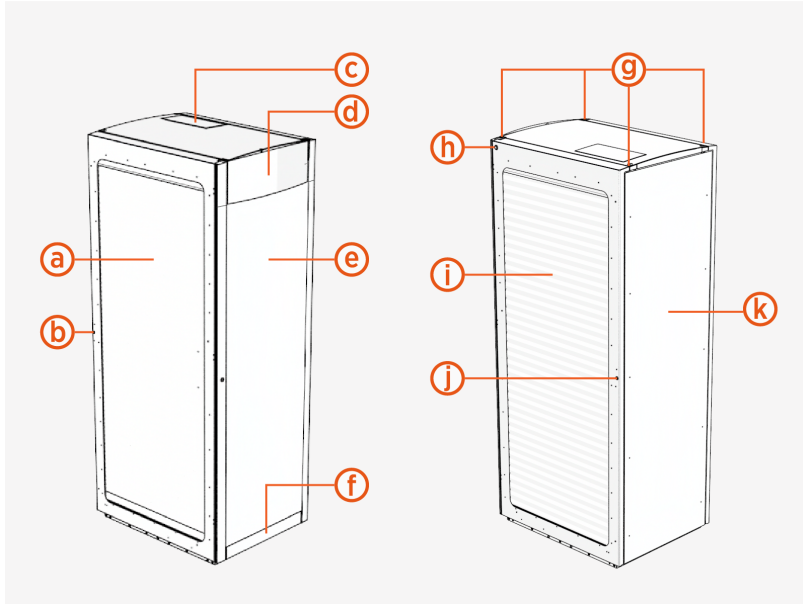

Ref	Part	Ref	Part
(a)	Exhaust (left) door with airflow vents	(g)	Lifting points
(b)	Exhaust door lock	(h)	Status LED
(c)	Smart Antenna (optional)	(i)	Intake (right) door with airflow vents
(d)	Logo plate (customizable)	(j)	Intake door lock
(e)	Front panel (with customizable vinyl)	(k)	Rear panel
(f)	Front bottom plate		

# Cabinet Configurations

Power Block 2000 is available in single-, double-, or triple-cabinet configurations, as shown below. The double- and triple-cabinet models ship as a single integrated unit, with the cabinets factory-bolted together.

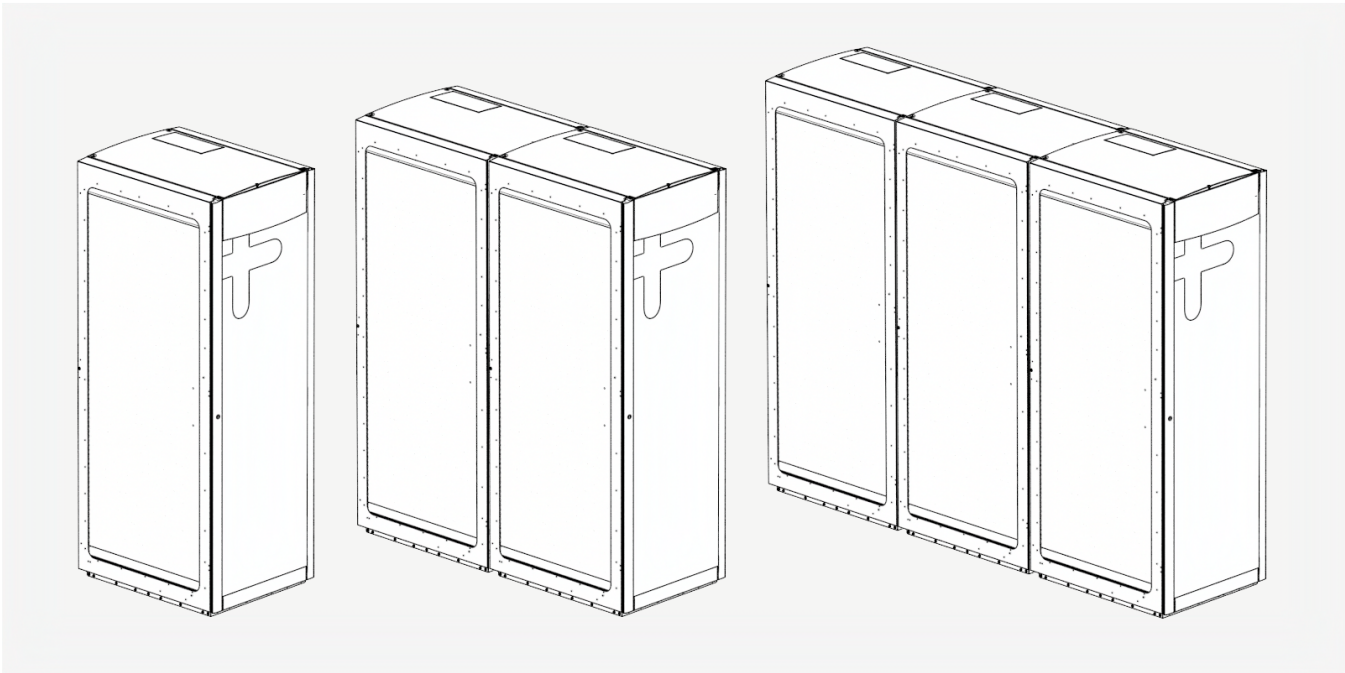

The side doors for each cabinet section swing open towards the front of the unit.

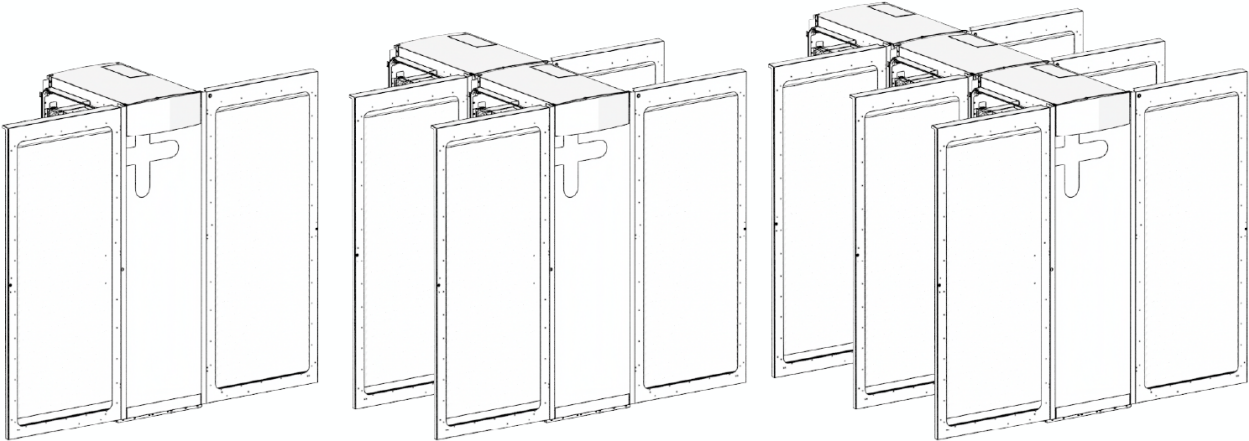

# Interior Parts

The following shows the interior views of the single-cabinet Power Block 2000:

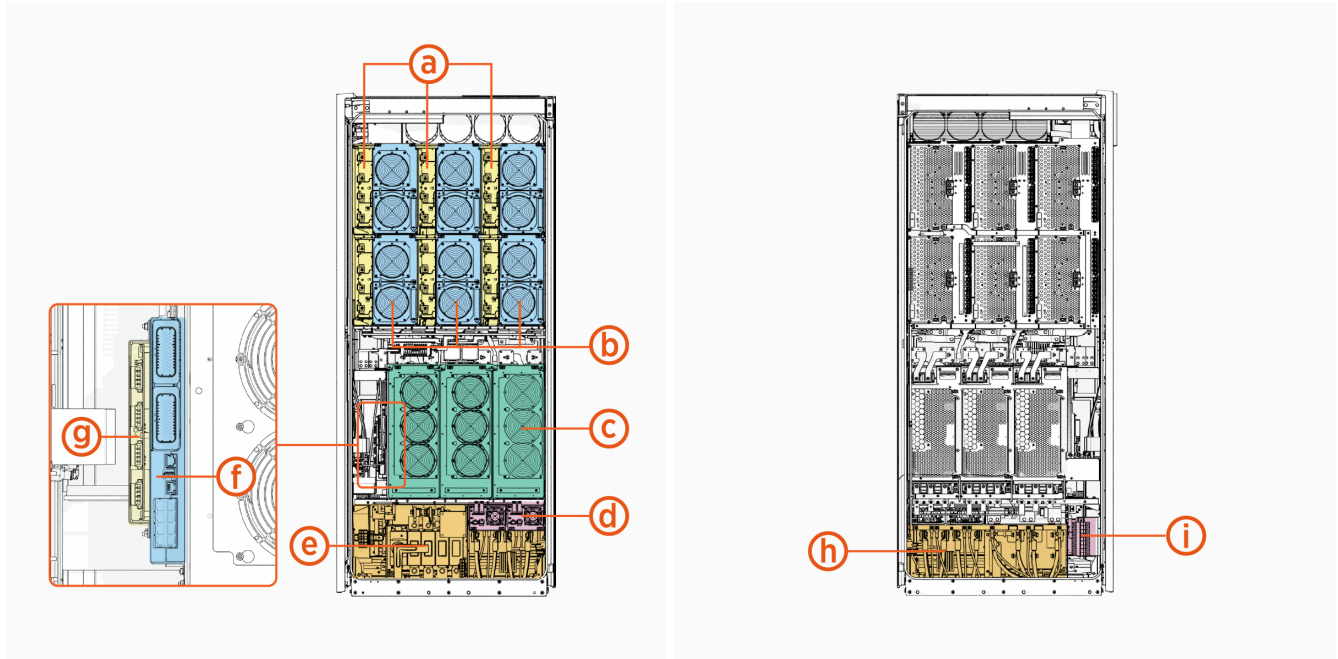

**Intake (Right) Side**

**Exhaust (Left) Side**

Ref	Part	Ref	Part
(a)	Contactor matrix	(f)	Power Management Controller (PMC)
(b)	DC power modules	(g)	Safety Hub Board (SHB)
(c)	AC power modules	(h)	Wire terminals and bus bars, exhaust side
(d)	Aux power supply (AUX PS) modules	(i)	48 V DC fuse block
(e)	Wire terminals and bus bars, intake side		

The interior parts shown above are present in each cabinet of the double- and triple-cabinet Power Block 2000.

---

## System Description

The Power Block 2000 intakes 3-phase AC grid power and performs power conversion with two types of modules:

- **AC Power Module** – The AC power module converts AC input power to DC output power. Up to three modules can be installed into each Power Block 2000 cabinet to scale total power capacity.
- **DC Power Module** – The DC power module is an isolated, bidirectional DC/DC converter that conditions power for delivery to downstream EVs.

The Power Block 2000 has two separate DC power distribution buses:

- **DC Grid Bus** – The DC Grid Bus is a non-isolated DC bus (up to 950 V depending on region and application). Multi-cabinet Power Block 2000s can ship with their DC Grid Buses interconnected for power sharing. DC Grid functionality is supported only on 480 V AC and 400 V AC Power Block 2000 models; 600 V AC models do not support DC Grid.
- **DC Output Bus** – The DC Output Bus is an isolated DC bus (100–1000 V) that delivers regulated output power to connected EVs. Power flow from the DC Output Bus is routed through the Contactor Matrix, which selectively connects to a set of discrete external DC outputs.

The Power Block provides the following external DC outputs:

- Power Block 2000 is available with four, eight, or twelve external DC outputs per cabinet, designated EXT A, EXT B, EXT C, and so on through EXT L.
- Each output can supply power to a single input power path of a Power Link charging dispenser.

The Power Block 2000 is equipped with an Auxiliary Power Supply (APS) system:

- **Auxiliary Power Supply (AUX PS) Modules** – Each cabinet includes AUX PS modules that generate 48 V DC power for internal electronics and sub-assemblies within the unit.
- **48 V DC Output** – Each Power Block 2000 cabinet provides 48 V DC outputs for supplying power to connected Power Link charging dispensers.

The Power Block 2000 features an integrated system that facilitates safe and reliable communication and control:

- **Power Management Controller (PMC)** – The PMC controls power flow within the system. It communicates with the power converters and the contactor matrix to manage the delivery of power to the external DC outputs. The PMC supports Ethernet ports for communication with various components like connected Power Link charging dispensers and interconnected Power Block 2000 cabinets to ensure seamless operation. In the event of a fault, the PMC can instruct the power converters to stop power delivery and open the contactors to isolate the power source.
- **Contactor Matrix** – The contactor matrix receives commands from the PMC to open or close the contactors as needed.
- **Safety Hub Board (SHB)** – In addition to processing fault reports from the Neutron, the SHB supports four dispenser ports for performing continuous electrical isolation monitoring of connected Power Link charging dispensers. Any faults detected are reported to the PMC.



**NOTE:** Safety Hub monitoring is not required for all models of Power Link. Contact [ChargePoint](#) for details.

# System Interfaces and Sample Architecture

The following provides a high-level overview of the electrical interfaces of a Power Block 2000. The diagram also illustrates the interconnections required for an example architecture in which the Power Block 2000 provides DC output power to the input power paths (A and B) of two Power Link 2000s. The Power Link 2000s are each equipped with two charging cables (L and R). Note that Power Link 2000 does not require Safety Hub (SH) monitoring.

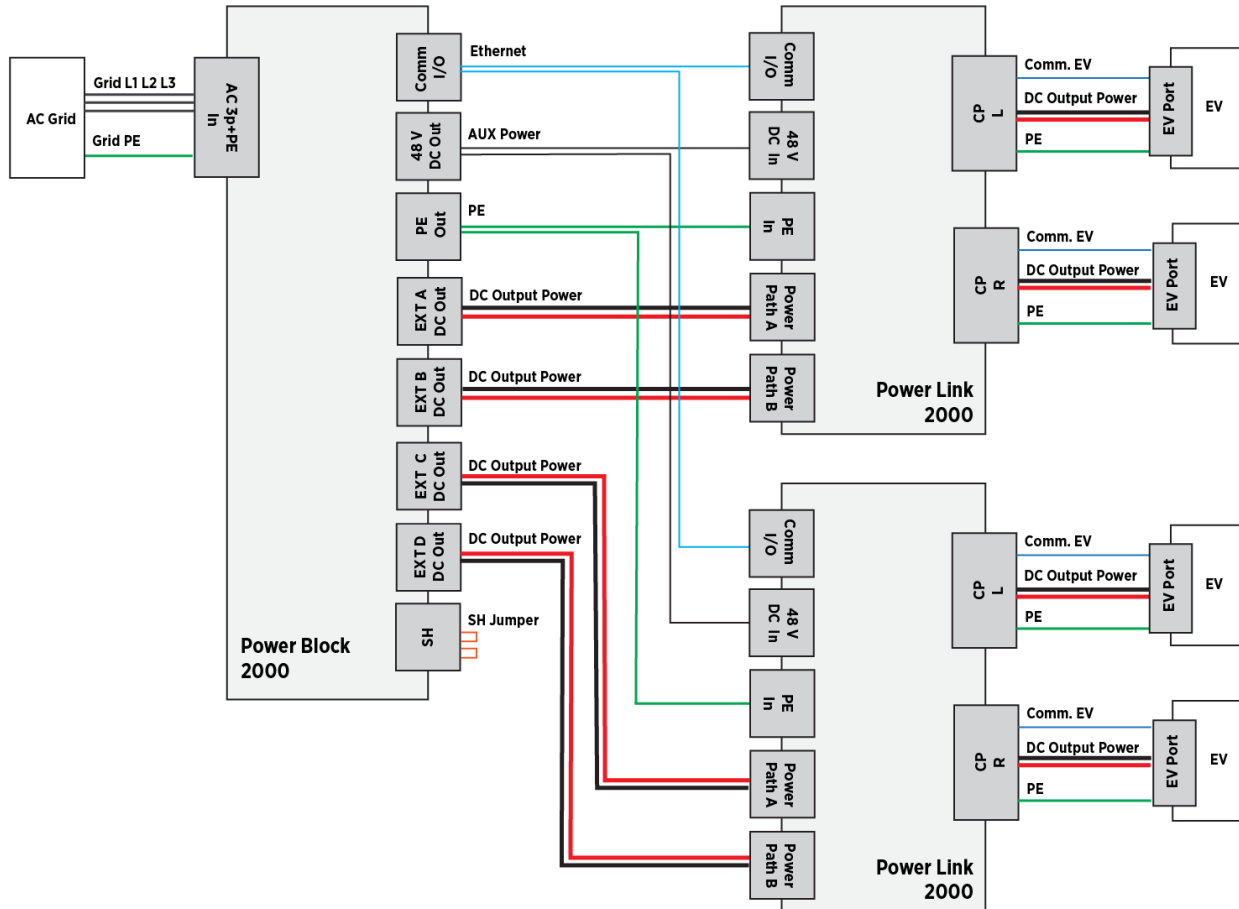

**IMPORTANT:** Power Block 2000 can be configured in many different system architectures, only one of which is shown above. The actual architecture for each site will vary depending on the number of stations, the charging capacity required at each charging station, charging requirements, and other criteria. If you are a site designer, contact a ChargePoint representative for the ChargePoint-approved wiring architecture for your specific project. Systems configured with non-approved wiring between Power Block 2000 and paired stations may not function as expected. If you are an installer, see the site plan for the architecture specific to the site installation project.

## Product Guides

A full suite of guides is available for Power Block 2000, as summarized below.

Document	Content	Primary Audiences
Datasheet	Full station specifications	Site designer, installer, and station owner
Site Design Guide	Civil, mechanical, and electrical guidelines to scope and construct the site	Site designer or engineer of record
Construction Signoff Form	Checklists used by contractors to ensure the site is correctly completed and ready for product installation	Site construction contractor
Installation Guide	Anchoring, wiring, and powering on	Installer
Operation and Maintenance Guide	Operation and preventive maintenance information	Station owner, facility manager, and technician
Service Guide	Component replacement procedures, including optional components	Service technician
Declaration of Conformity	Statement of conformity with directives	Purchasers and public

Access ChargePoint documents at [ChargePoint Product Reference Documentation](#).

## Questions

For assistance, go to [chargepoint.com/support](https://chargepoint.com/support) and contact technical support using the appropriate region-specific number.

# Site Planning and Placement **2**

This section outlines general planning and placement requirements for Power Block 2000 sites.

## Initial Site Guidelines

The site designer must perform an onsite evaluation to determine conduit and wiring requirements from the panel to the proposed charging locations, and to measure cellular signal levels and identify suitable locations for any required cellular signal-booster equipment.

If you have pre-existing infrastructure or are using your own preferred electrical contractor to prepare your site, a *Power Block 2000 Construction Signoff Form* completed by a ChargePoint Operations and Maintenance (O&M) partner is required to certify compliance with electrical code and to ensure everything was prepared to ChargePoint specifications.

## Plan for Future Charging Capacity

Designing electrical infrastructure to support current and future needs for EV charging helps avoid costly upgrades later as demand for EV charging grows.

Consider these methods to prepare a site for future charging stations in a later phase of work:

- Add extra capacity if electrical panels are being upgraded now.
- Use sub-panels as a way to shorten electrical paths.
- Maximize the conduit and conductor sizes (to product specifications) between the main electrical panel and future stations, to prevent needing to re-pull wire later.
- Below-ground wiring can be pre-staged if the correct site construction is performed in advance. Allowed terminations include a distribution unit, junction box, or plugged conduit. This eases cable pulls for future stations.
- Consider locations and spaces where it will be easy to add future stations.

# System Placement

The placement of Power Block 2000 must meet the following requirements:

- Power Block 2000 is not ATEX rated shall not be installed in an explosive area.
- Site conditions must be compatible with the following specifications listed in the *Power Block 2000 Datasheet*:
  - Operational altitude
  - Operating temperature
  - Operating humidity
  - Enclosure rating
- Power Block 2000 must be installed on a level concrete surface rated for the weight of the station.



**WARNING:** The charging station must be installed on a level concrete base rated for the weight of the station. Asphalt cannot support the full weight of the station. Failure to install the station on a suitable surface may cause the station to tip over, resulting in death, personal injury, or property damage.

Layout considerations:

- Determine appropriate ground anchoring locations where concrete exists or can be installed.
- Consider locations where it will be easy to add future stations.
- If using conduits to pull wires, determine the best conduit layout to minimize linear conduit costs to multiple parking spaces. If possible, avoid or minimize trenching requirements, especially more costly trenching to run conduit under asphalt surfaces.
- Determine if the existing utility service and electrical panel capacity is sufficient. Identify costs for any necessary upgrades and/or a new dedicated electrical panel. ChargePoint recommends using a licensed electrician to evaluate available capacity and identify any upgrades that may be required.
- If a dedicated EV electrical panel is required, choose a panel located close to the existing electrical supply.
- Measure cellular signal levels to ensure adequate cellular coverage at the station locations. To ensure adequate signal strength in underground or enclosed parking structures, cellular repeaters may be required. For more information, see [Connectivity](#).
- ChargePoint recommends avoiding locations under trees where sap, pollen, or leaves would fall on the charging station and increase the station owner's site maintenance workload.

# Civil and Mechanical Design 3

This section describes civil and mechanical site design guidelines for Power Block 2000.

## Dimensions



**NOTE:** Images given in this section are not to scale. Measurements appear in metric units (mm), followed by imperial equivalents (inches).

# Single-Cabinet

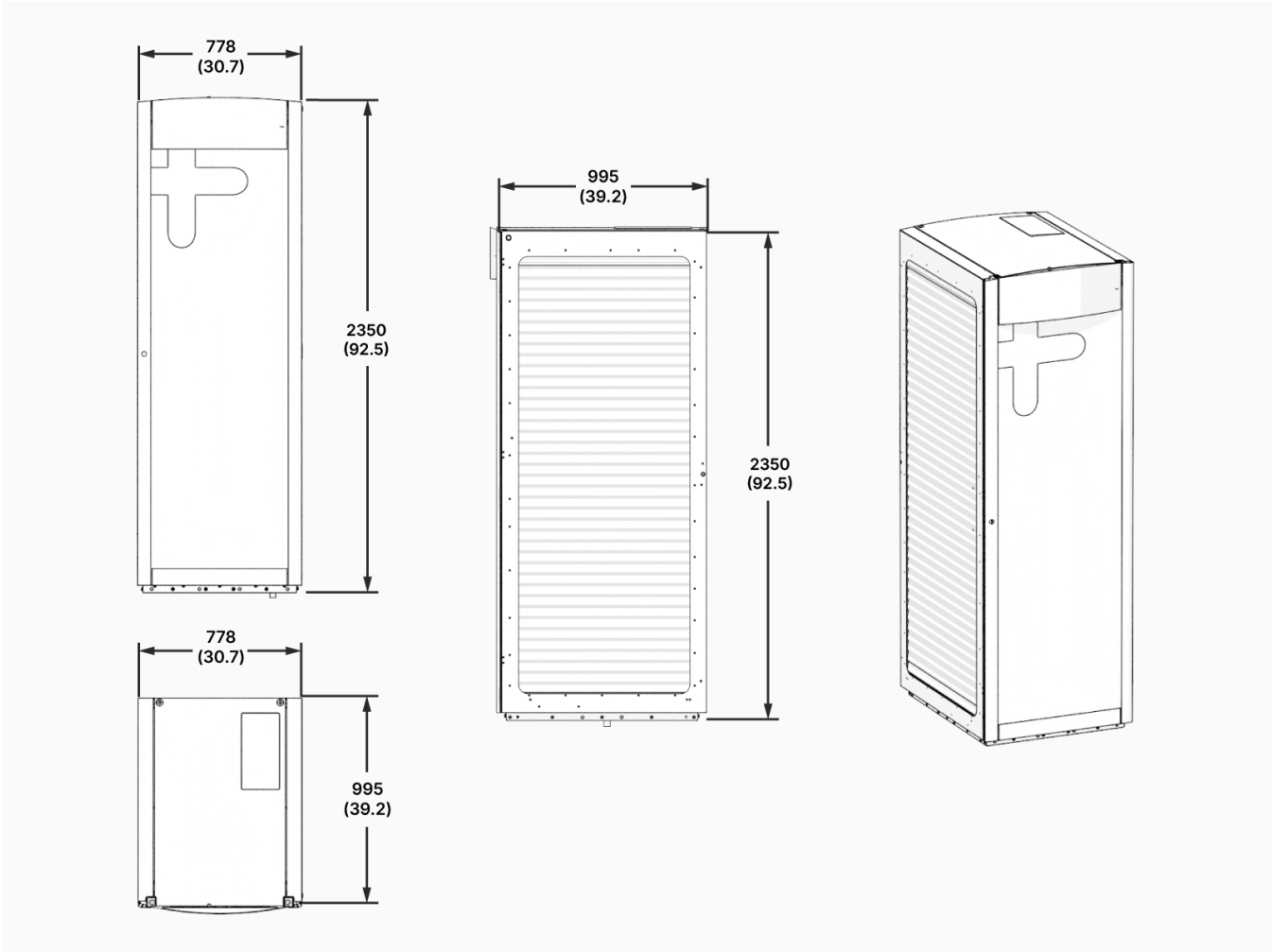

# Double-Cabinet

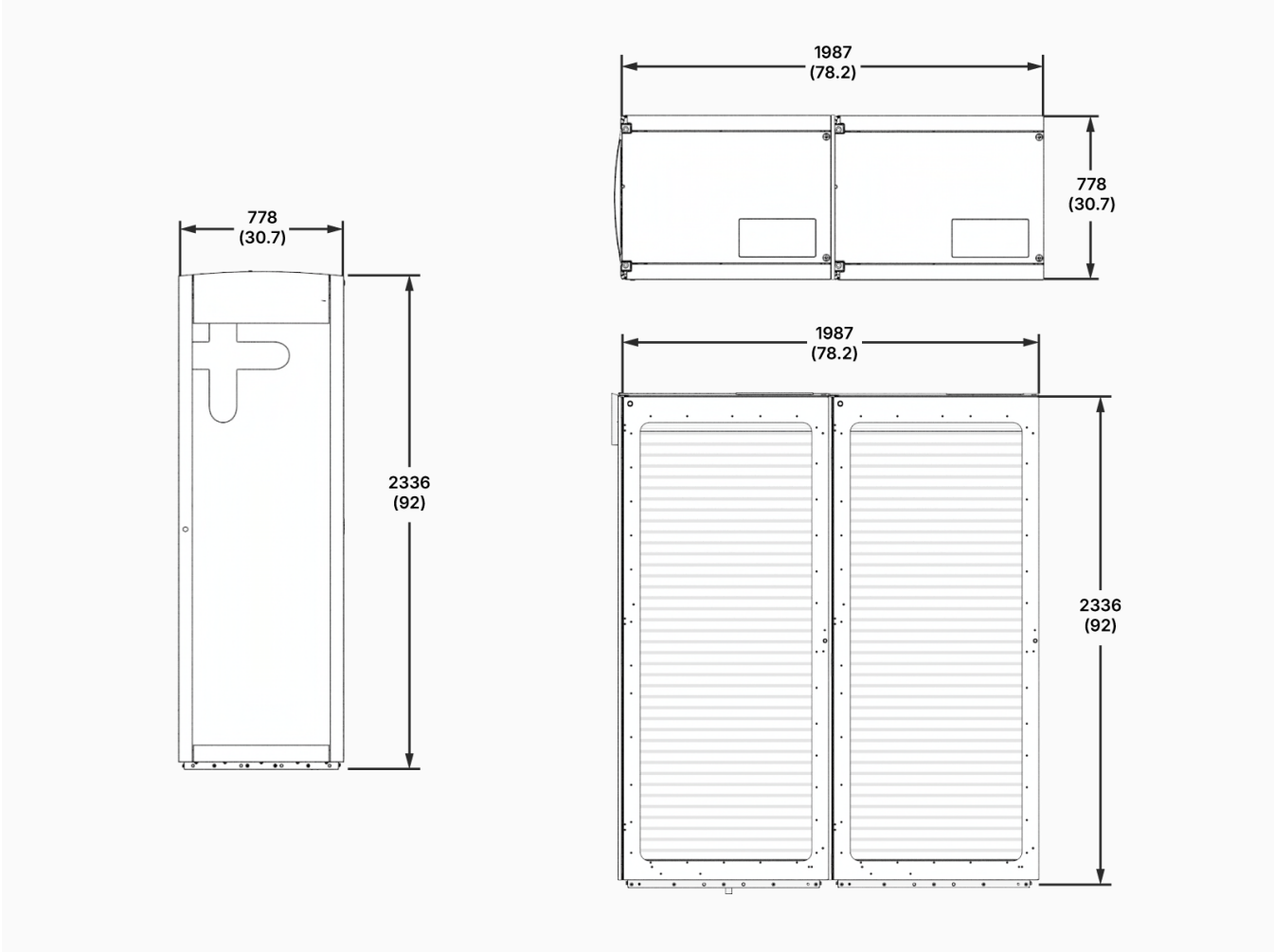

# Triple-Cabinet

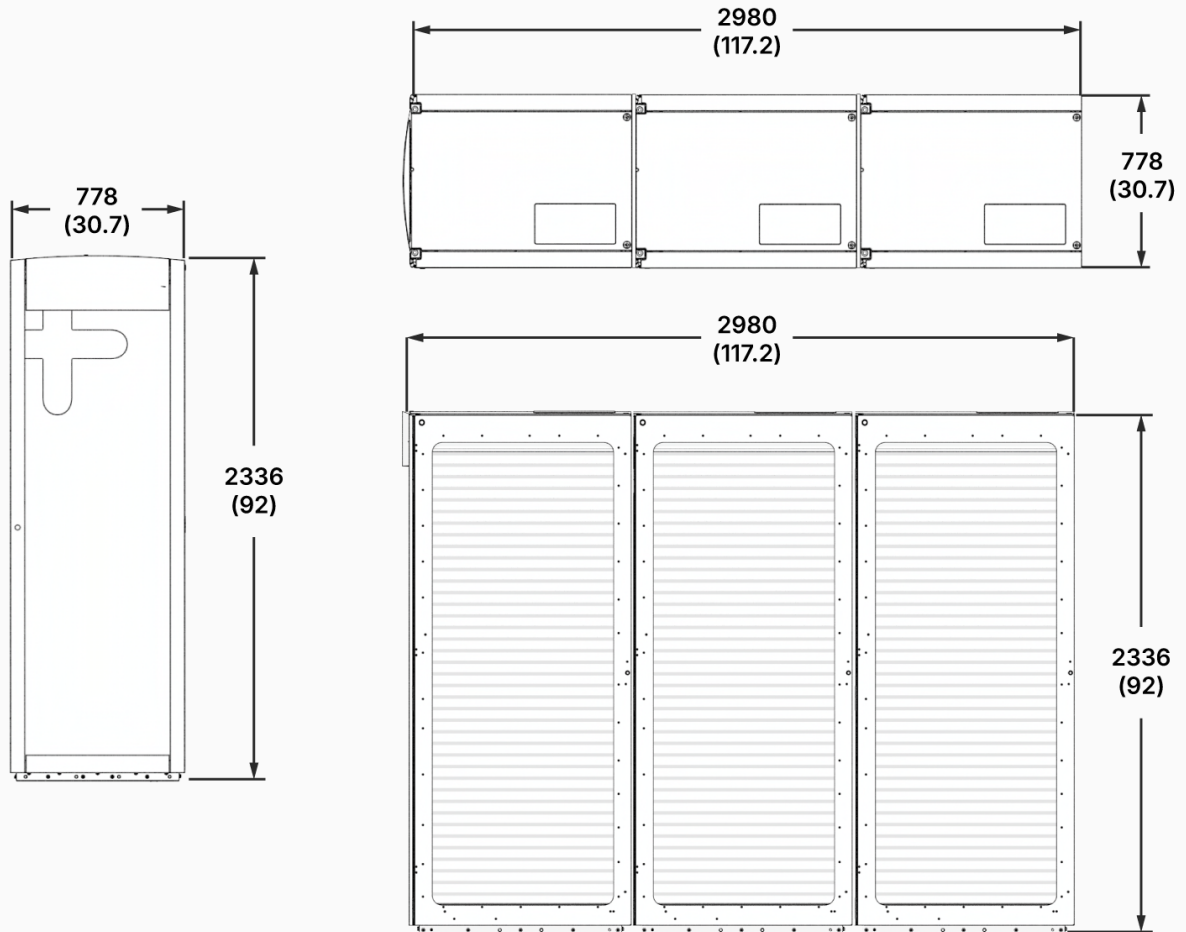

## Weights

The following enables calculation of the Power Block 2000 weight, depending on its configuration:

Component	Weight
Power Block 2000 – Single-cabinet (fully loaded)	1300 kg (2866 lb)
Power Block 2000 – Double-cabinet (fully loaded)	2600 kg (5732 lb)
Power Block 2000 – Triple-cabinet (fully loaded)	3900 kg (8598 lb)
AC power module (single module)	93 kg (205 lb)
DC power module (single module)	68.5 kg (151 lb)

# Mount Specifications



**WARNING:** If not installed correctly, ChargePoint charging components may pose a crushing hazard, leading to death, personal injury, or property damage. Always use a ChargePoint-approved mounting method to install the ChargePoint charging components, as described in this section. Always install in accordance with applicable codes and standards using licensed professionals. Non-approved installation methods are performed at the risk of the contractor and void the Limited One-Year Parts Exchange Warranty.

## Concrete Pad Specifications

Power Block 2000 must be installed on a concrete pad or engineered foundation. The concrete pad may be either newly poured or it may be an existing concrete surface.



**IMPORTANT:** The concrete surface must be smooth and level. If an existing concrete surface does not meet the level requirement, a localized leveling pad must be poured.

To design a site-specific new pad, submit the following parameters for a structural engineering analysis. The table consolidates all required inputs—whether provided directly here or defined elsewhere in the guide—so the structural engineer receives a complete and consistent set of values.

Parameter	Value
Weight	See <a href="#">Weights</a>
Height x width	See <a href="#">Dimensions</a>
Frontal area	Height x Width as given in <a href="#">Dimensions</a>
Center of gravity height	1349 mm (53.1 in)
Anchor bolts size and quantity	M20 (x4 per cabinet)
Anchor bolts pattern	See <a href="#">Anchor Bolt Pattern</a>

Alternatively, if installing on an existing pad, a structural engineer must:

- Inspect and approve the existing pad for use, based on the parameters listed above
- Verify the anchor bolt embedment for structural strength

For additional information on using an existing pad, see [Surface Mount](#).

# Anchor Bolt Pattern



**NOTE:** Images given in this section are not to scale. Measurements appear in metric units (mm), followed by imperial equivalents (inches).

Power Block 2000 mounts over anchor bolts embedded in a concrete pad with the anchor bolt pattern shown below. The image perspective is looking from the ground up at the bottom plate of the cabinets.

Single cabinet anchor bolt pattern:

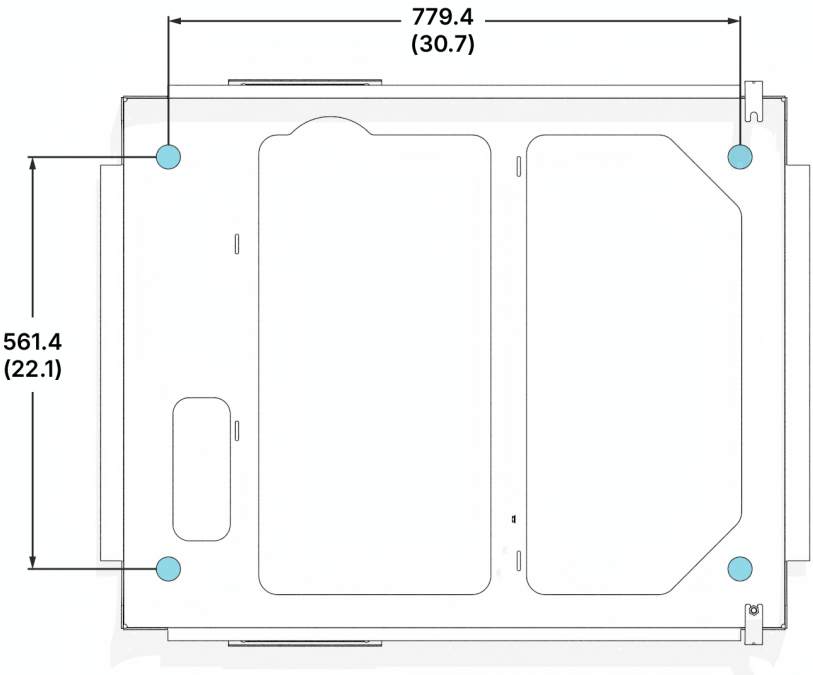

Multi-cabinet anchor bolt pattern:

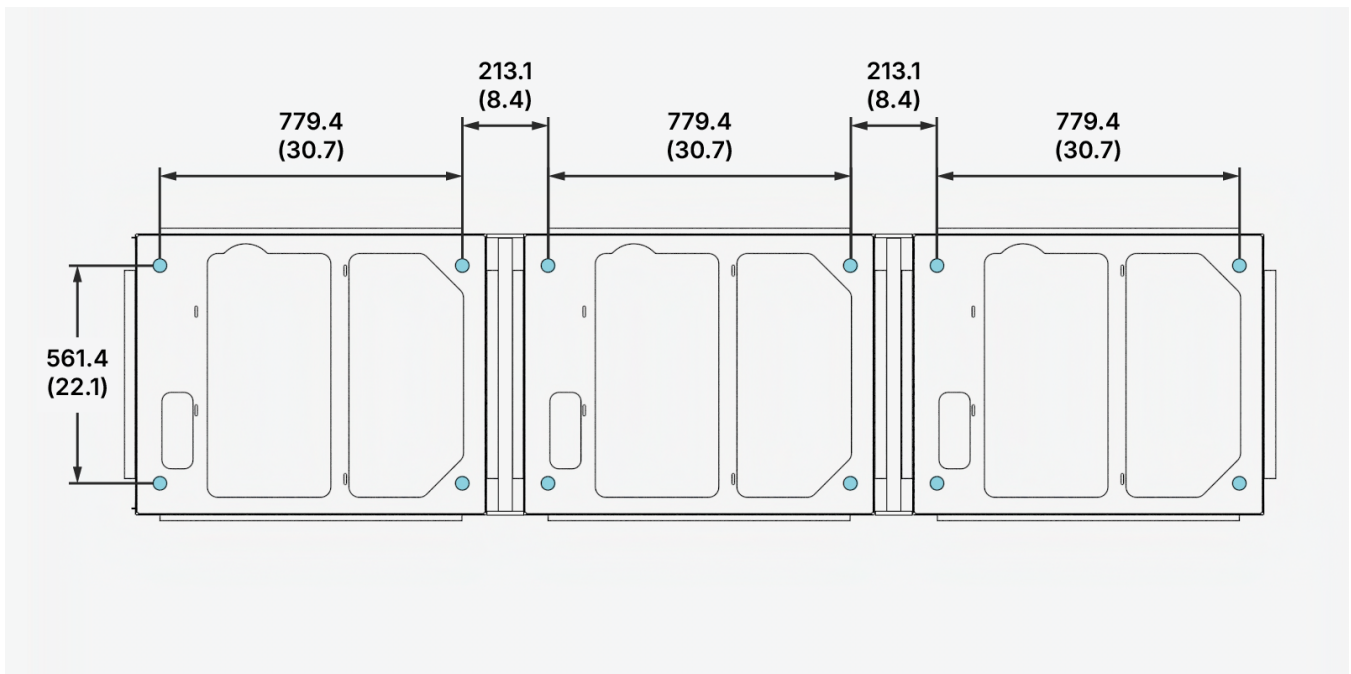

The distance from the center of each anchor bolt to its adjacent enclosure walls is 108 mm (4.25 in).

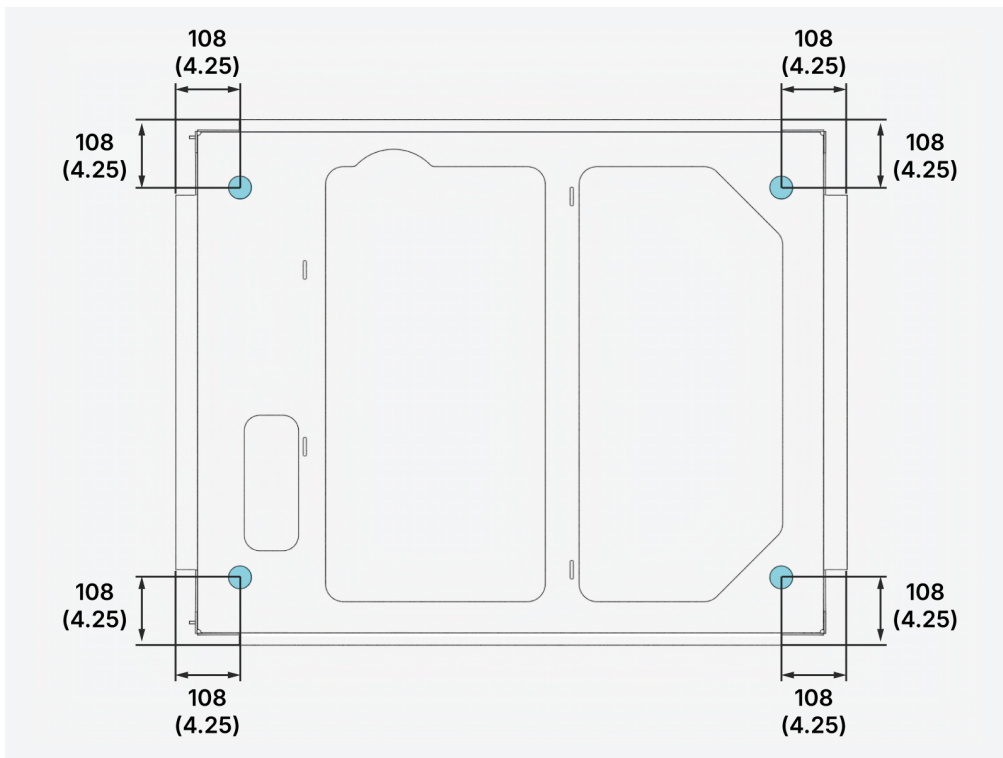

## Standard Mount

The most common mounting method for Power Block 2000 is a new pad installation using a Concrete Mounting Template (CMT) and conduit stub-up wire entry.

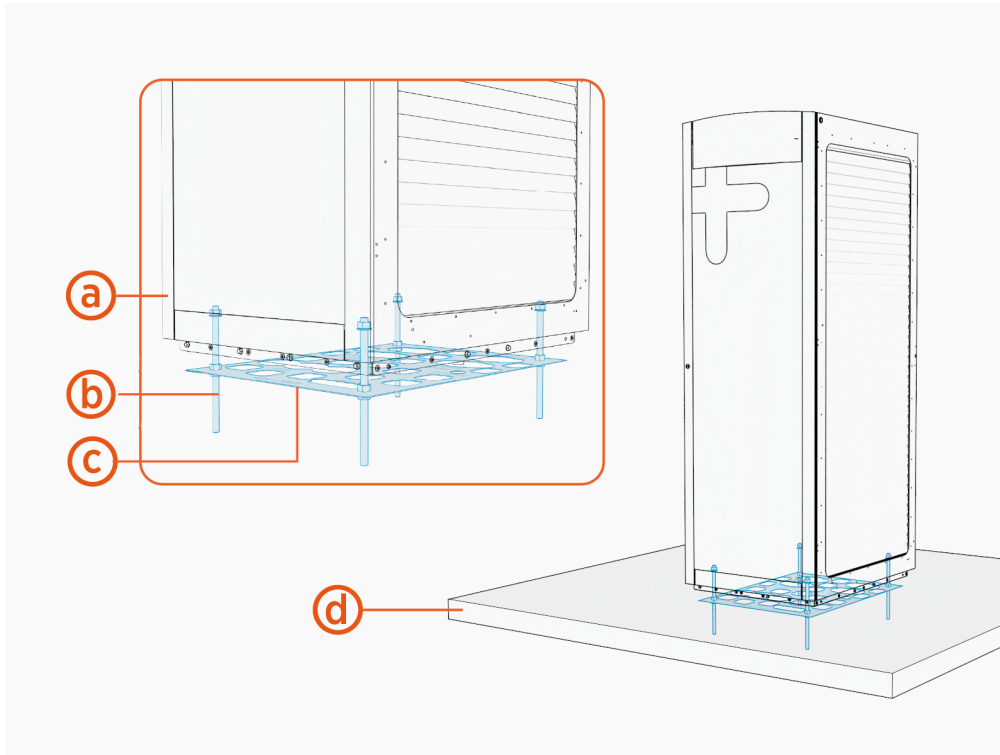

- The Power Block 2000 (a) mounts onto four M20 anchor bolts (b) exposed 127 mm (5 in) above the concrete pad.
- The CMT (c) is embedded into a newly poured concrete pad (d) to align anchor bolts and underground stub-up wiring conduits. (Conduits are not shown in illustration.)

### IMPORTANT:



- The CMT is shipped separately and must be assembled onsite before pouring the concrete pad.
- One CMT is required beneath each Power Block 2000 cabinet.
- The CMT must be embedded with its top panel positioned 51 mm (2 in) below the concrete surface.

## Concrete Mount Template

The concrete mount template (CMT) positions the anchor bolts and wire entry points as shown below.

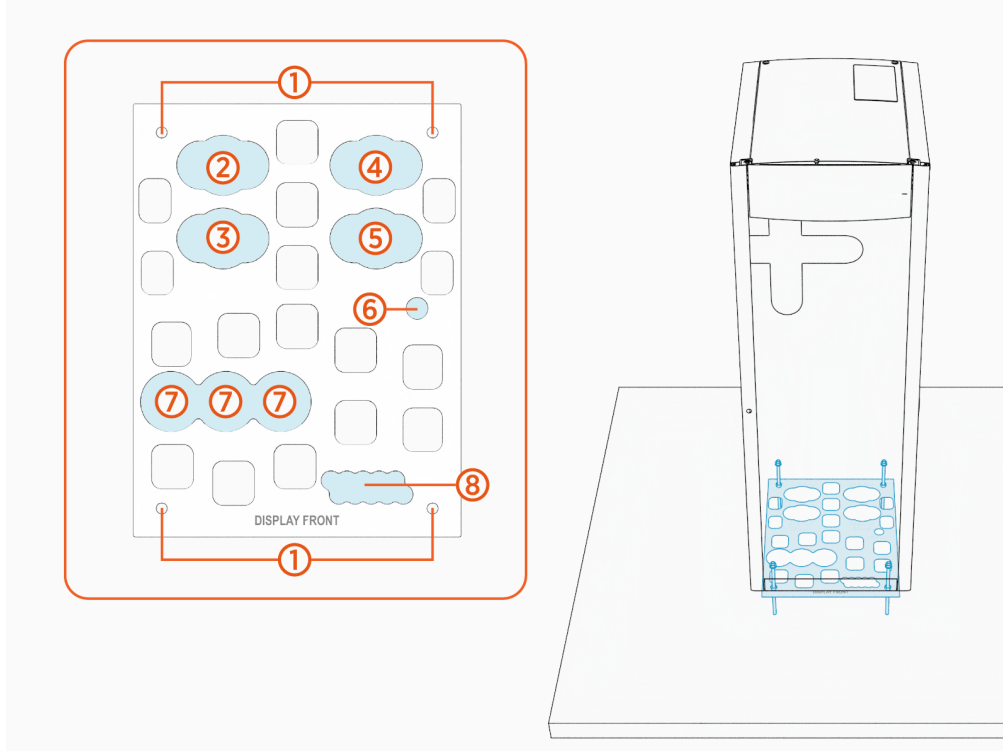

Ref	4 DC Output	8 DC Output
(1)	M20 anchor bolts	
(2)	EXT D wires	EXT G and EXT H wires
(3)	EXT C wires	EXT E and EXT F wires
(4)	EXT B wires	EXT C and EXT D wires
(5)	EXT A wires	EXT A and EXT B wires
(6)	Shunt trip wires	
(7)	AC input wires	
(8)	48 V DC output, Ethernet, and Safety Hub wires	

For conduit quantity and size requirements, refer to [Conduit Requirements](#).

## Surface Mount

Power Block 2000 may be installed on an existing concrete surface in accordance with the following guidelines:

- The concrete surface must be inspected and approved by a structural engineer using the structural parameters given in [Existing Pad Structural Analysis Parameters](#).



**IMPORTANT:** Verify the anchor bolt embedment for structural strength.

- The anchor bolts must be installed in the concrete surface as follows:
  - Anchor holes are drilled into the concrete using the anchor bolt pattern given in [Anchor Bolt Pattern](#). The holes are drilled to a depth so that 127 mm (5 in) of each anchor bolt is exposed above the concrete pad.
  - Anchor bolts are epoxied into the holes. Use an epoxy with a minimum bonding strength of 11.7 MPa, compressive strength of 82.7 MPa minimum, and tensile strength of 49.3 MPa minimum. Examples include Hilti HIT-RE 500 V3 (normal cure) or Hilti HIT-HY 200-A (fast cure).

### NOTE:



- Epoxy is required only if embedding anchor bolts into an existing concrete pad. It is not applicable for a new concrete pour with CMT.
- Different epoxy types have different cure times at various temperatures. Check local temperatures for the site in advance to help choose an appropriate epoxy.

- The anchor bolts must be hot dip galvanized. In coastal or other high-corrosion environments, consult a corrosion specialist to determine an appropriate bolt material and coating system.
- Surface mounted Power Block 2000 must utilize [surface conduit entry](#).

## Surface Conduit Entry

Power Block 2000 can be installed on a platform for surface conduit entry. [Contact ChargePoint](#) for more information.

## Drainage

Ensure any site slopes, walls, or fencing do not trap water around the installation site.

## Flood Plane

Power Block 2000 is designed for a 61 mm (2.4 in) flood plane. If the site has a flood plane greater than 61 mm (2.4 in) for a 100-year flood event, consider installing Power Block 2000 on a raised concrete pad.



**WARNING:** Exposing Power Block 2000 to over 61 mm (2.4 in) of standing water could create an electrocution, shock, or fire hazard.



If a Power Block 2000 has been exposed to standing water, cut power to the component and contact ChargePoint before the component is powered on.

## Clearances

Power Block 2000 has clearance requirements on its intake (right) and exhaust (left) sides for installation, service, maintenance, and ventilation.

The side doors can be swung open on their hinges, allowing for convenient access for service and maintenance. If needed, the doors may be removed from the cabinet for service access.

In some installation scenarios, an opened side door may obstruct access to the cabinet, such as shown below under Option 1. Installing the cabinet rotated 180 degrees (Option 2) allows full service access without door removal.

### Option 1

Service Access: Blocked (door removal required)

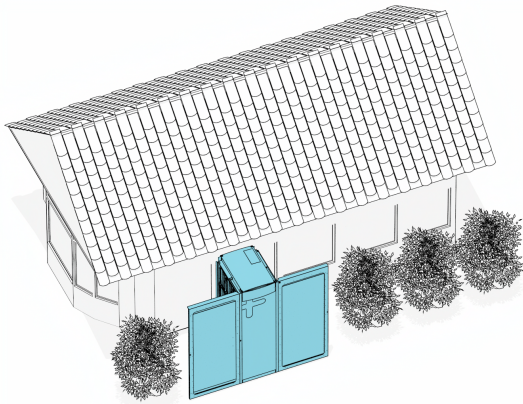

### Option 2

Service Access: Clear

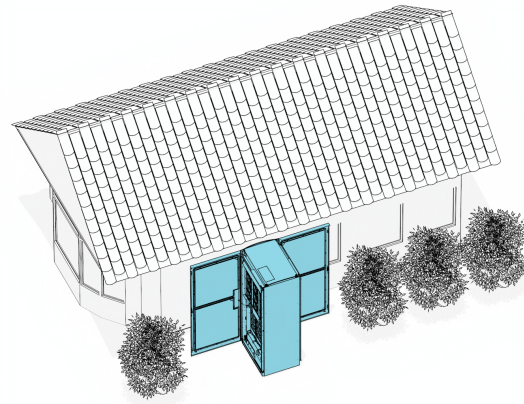

Mandatory and recommended clearance requirements for the single-cabinet Power Block 2000 are given below. The figure shows a top-down view of the Power Block 2000 cabinet overlaid on the CMT.



**NOTE:** Images given in this section are not to scale. Measurements appear in metric units (mm), followed by imperial equivalents (inches).

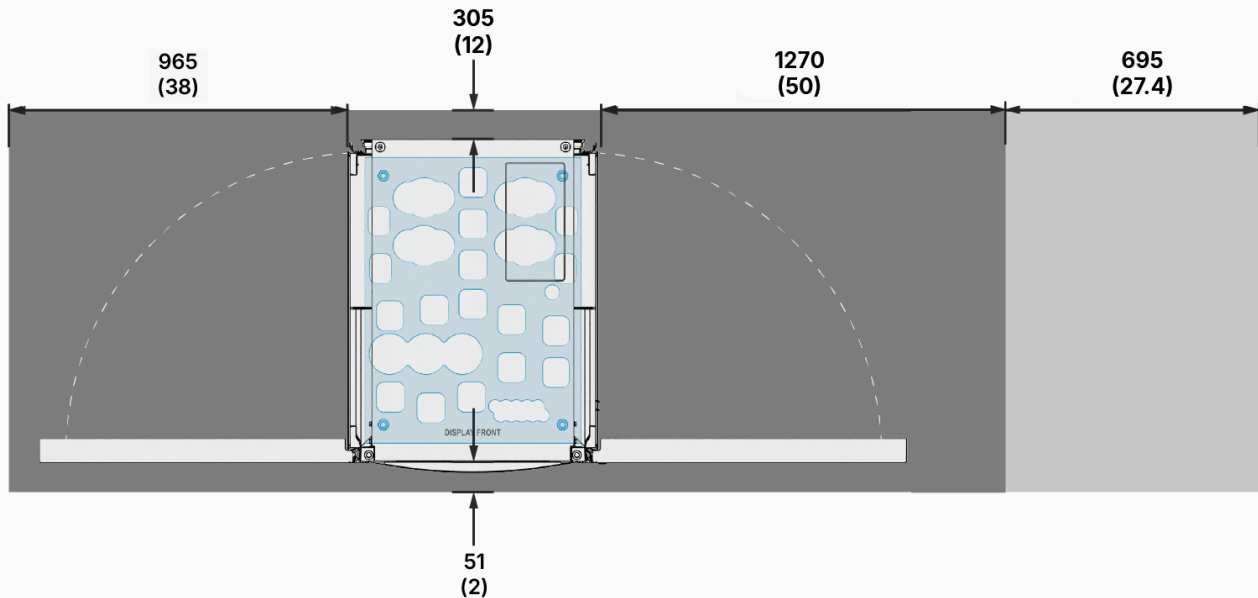

- Mandatory clearance area
- Recommended additional clearance area

The recommended additional clearance improves serviceability. If this clearance is not available, the door may need to be removed during service.



**IMPORTANT:** The ground within the defined mandatory clearance areas must be firm, stable, at grade (+/- 13 mm or 0.5 in), and free of any elevation changes. The same is required if the recommended clearance area is maintained. This ensures safe access when working with tools such as a module lifter, ladders, or similar equipment. Failure to maintain the required clearances or to ensure proper ground conditions may obstruct or prevent essential service operations or result in damage to the product.

Power Block 2000s installed side by side may share clearance areas, as shown below. When installing multiple rows of cabinets, orient the rows so that the air intakes face each other to ensure proper thermal management.

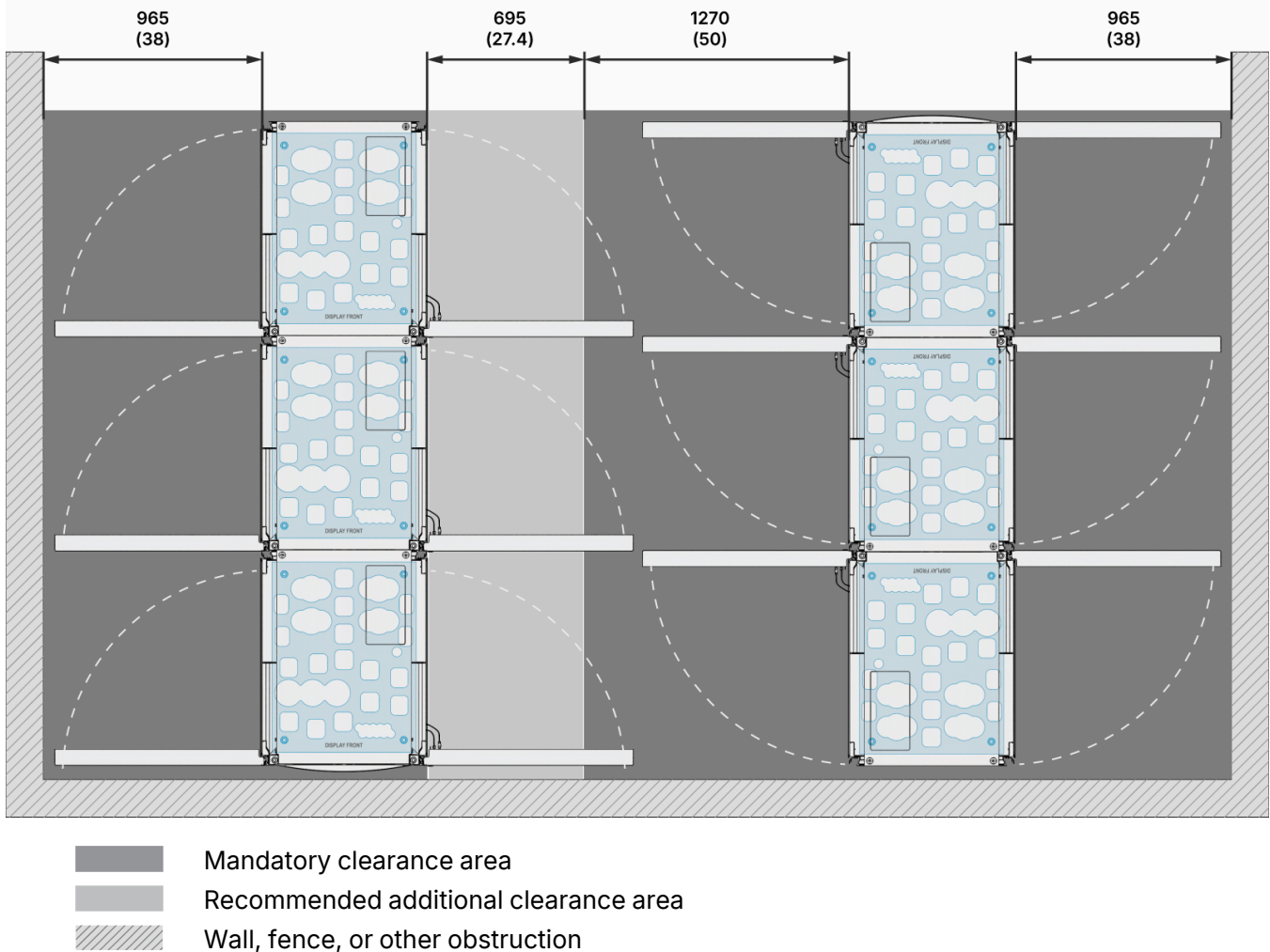

**NOTE:** When sharing side clearances, the recommended additional clearance area is highly advised.

The figure below shows the minimum footprint for two triple-cabinet Power Block 2000s installed side by side.

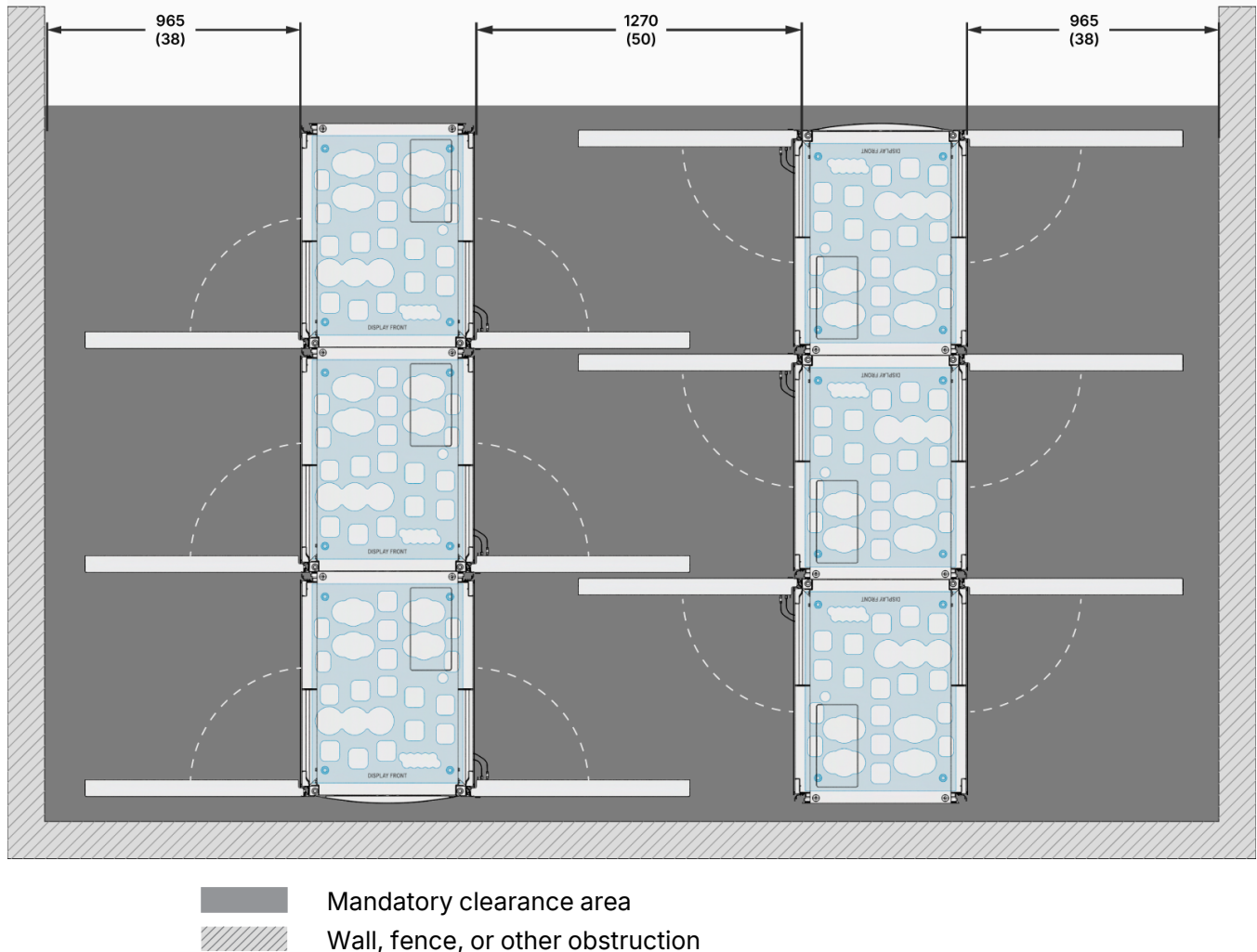

**NOTE:** In the minimum footprint layout shown above, the surrounding wall limits access, so the doors must be removed for service at two of the aisles.

Additionally, follow the clearance guidelines below:

- The status LEDs must not be obstructed from view. See [Exterior Parts](#) for the location of the status LEDs.
- After site make-ready, the only way to confirm that clearance requirements have been met is to inspect the position of the anchor bolts. See [Anchor Bolt Pattern](#) for the distance between the anchor bolts and the cabinet walls.
- Check local and regional codes for any additional clearance requirements regarding safety, high voltage equipment, and accessibility requirements.
- For any questions about allowable layouts, [contact ChargePoint](#).

## Bollards

Bollards are not explicitly required by ChargePoint. If applicable, ChargePoint recommends these best practices and considerations when designing bollards for the site:

- Permanent bollards must not encroach upon the clearance areas described in [Clearances](#).
- Removable bollards are allowed if service personnel have the ability to move them as needed.

Bollards and wheel stops each has advantages and disadvantages. Factors to consider include: cosmetics, usability, accessibility and vehicle types.

Wheels stops offer the following advantages:

- Clean look
- Less chance of cables getting tangled with bollards

Bollards offer the following advantages:

- Larger vehicles and sites with mixed vehicle sizes that have different overhangs (trucks vs. light duty vehicles)
- More visibility while backing up

## Ventilation

Intake vents are located on the right side of the Power Block 2000, and exhaust vents are on the left side when facing the front of the cabinet. When positioning multiple Power Block 2000s, position intake and exhaust sides of the cabinet to avoid recirculation.

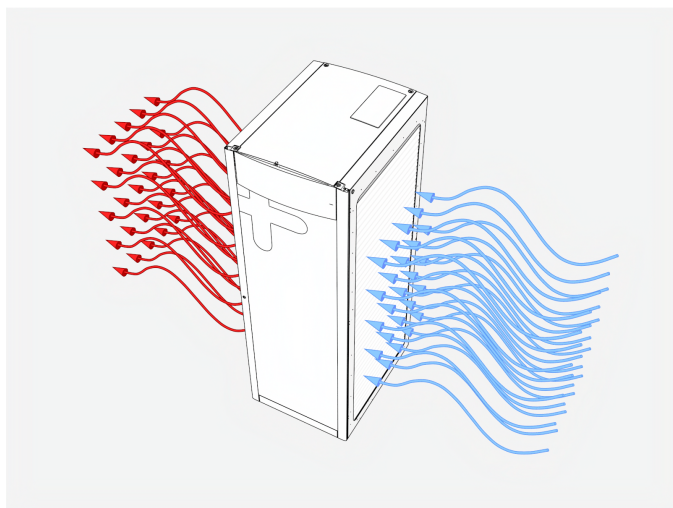

**NOTE:** Power Block 2000 requires 33 kW (112,600 BTU/hr) of heat rejection.

## Signage

Refer to local and regional code to design the following elements for the site:

- Any required re-stripping of parking spaces
- EV or Accessible EV signs
- EV or Accessible EV paint markings on and around the parking spaces

# Electrical Design 4

This section provides electrical design guidelines for Power Block 2000.

## Electrical Supply Requirements

EV charging equipment operates as a continuous load, drawing high current for extended periods. Branch-circuit conductors and protective devices must therefore be sized in accordance with applicable local electrical regulations for continuous-load operation.

When planning multiple EV charging stations, it is best practice to segment non-continuous and continuous loads, with all branch circuits for EV charging on a dedicated electrical panel assembly with adequate circuit breakers. When sizing new electrical panels dedicated for EV charging, all branch circuits must support continuous load.

Power Block 2000 is available in multiple power ratings: 350 kW, 500 kW, 525 kW

Each Power Block 2000 requires its own circuit breaker. Recommended breaker sizing is given below. Check with local code for breaker size requirements.

Recommended breaker size for the Europe region (400 V AC):

Max. Output Power	AC Nominal Input Current Rating	Recommended breaker size
Max. output power 350 kW	542 A	600 A
Max. output power 500 kW	789 A	800 A
Max. output power 525 kW	809 A	900 A



**IMPORTANT:** Power Block 2000 has a short circuit current rating of 100 kA.

Power Block 2000 is tested to IEC 61000-4-5, Level 5 (6 kV @ 3000 A) standards.

## Disconnect and Emergency Shutoff

Power Block 2000 ships with an AC disconnect switch for emergency shutoff. The switch is located on the intake side of the Power Block 2000 cabinet.

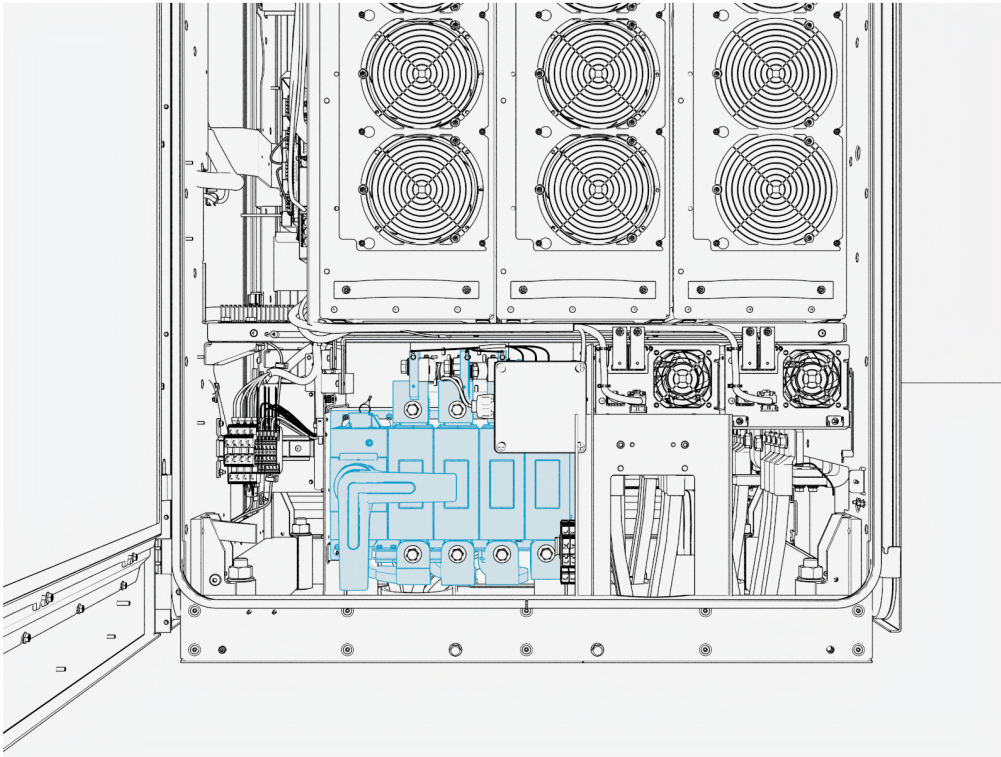

## Transformer Configuration

The table below provides the transformer configuration:

Parameter	Transformer Configuration
Input rating	400 V AC, 3-phase, 850 A, 50 Hz
Electrical service configuration	400 V AC 3-phase grounded WYE (Y) configuration  400 V AC 3-phase Delta (D) configuration (corner-grounded Delta transformer) is not acceptable
Product connection	Power Block 2000 must be connected to L1, L2, and L3 (neutral not required)

## Shunt Trip Wiring (optional)

Each cabinet of Power Block 2000 provides a set of unpowered (dry) contacts to connect to an optional shunt trip device. These contacts are rated to 240 VAC and 6 amps.

Wiring sections to and from Power Block 2000 are deactivated when unsafe conditions are detected, such as unintended cover panel removal. A breaker reset is required any time the shunt trip is activated.

If installed, each cabinet of the Power Block 2000 must be wired to the shunt trip unit of its own upstream circuit breaker. Upstream AC power must be shut off at the panel to remove shock risk inside the Power

Block 2000. All shunt trip behavior is already hard-coded into the Power Block 2000 and has no programmable variables.

Emergency stop devices are governed by local and regional codes and may be required in some sites. If one is required by code or by the site, confirm specifications with your ChargePoint representative.

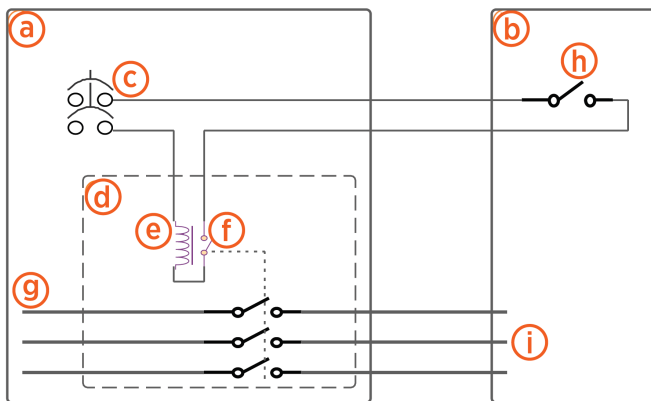

- (a) Electrical panel
- (b) Power Block 2000
- (c) Control voltage supply, maximum 240 VAC
- (d) Shunt trip circuit breaker
- (e) Shunt trip coil
- (f) Auxiliary contacts (closed when main contacts are closed)
- (g) 3-phase AC main
- (h) Power Block 2000 shunt trip contacts, Normally Open (inside the auxiliary power supply, accessible on field wiring terminal block)
- (i) 3-phase Power Block 2000 AC input

## Grounding Requirements

Power Block 2000 grounding requirements are given below:

- Power Block 2000 is categorized a class 1 equipment and therefore its chassis must be connected to a grounded, conductive, and permanent wiring system in accordance with IEC 60364 and/or applicable national standards.
- Provide a protective earth (PE) conductor sized according to local regulations.
- Power Block 2000 provides an isolated DC output. The DC positive and negative conductors must not be bonded to ground or protective earth. Grounding requirements apply to the equipment chassis only.
- Power Block 2000 is compatible with standard European earthing arrangements, including TN-S, TN-C-S, and TT systems. Installers must follow local code requirements for earthing and bonding.



**NOTE:** The leakage current from Power Block 2000 to the protective earth conductor can reach up to 200 mA.

# Soft Shutdown

The soft shutdown function is an optional feature that can be installed as a way to stop a charge session on a Power Block 2000. It is not meant to safely service the Power Block 2000 or take the place of a AC disconnect switch.

Each cabinet of a Power Block 2000 supports connection to a soft shutdown switch.

To use this feature, the installer must select and mount a physical soft shutdown switch (one per Power Block 2000 cabinet) with the following specifications:

- THHN insulation building wire rated to 600 V
- Normally Open (NO) configuration
- Switch current of 2 mA
- Switch voltage of 48 V
- Gold contacts suggested

When creating the site drawings, consider where any soft shutdown switches should be positioned. If applicable, consider disability and accessibility regulations for your region when choosing switch locations.



**NOTE:** Soft shutdown switch requires a dedicated wire conduit. For more information, refer to [Conduit Requirements](#).

When the switch is closed, the Power Block 2000 software ends the current charging session with a normal stop, then opens DC contactors in the Power Block 2000 cabinet. The station stays in this state regardless of station power, not allowing operation. Only a service technician can place the Power Block 2000 cabinet back into service after the switch is reset to Open.



**WARNING:** The external DC output wires from the Power Block 2000 could still be energized with the switch closed.

# Safety Hub

Safety Hub is a Power Block 2000 feature that provides continuous electrical-isolation monitoring to enhance system safety. When required, Safety Hub uses a dedicated twisted-pair connection routed from the Power Block 2000 Safety Hub Board to each associated Power Link. These conductors may share the same conduit as the 48 V DC and Ethernet wires serving the Power Links.

Safety Hub wiring requirements vary by Power Link model. Depending on the specific Power Link used in the installation, one of the following configurations will apply:

- Some Power Link models require a direct Safety Hub twisted-pair connection between the Power Block 2000 Safety Hub Board and the Power Link.
- Other Power Link models do not require a Safety Hub wire connection. For these models, a jumper wire must be installed on the Power Block 2000 Safety Hub Board instead of running twisted-pair wiring to the Power Link. This jumper is supplied with the Power Link and does not need to be sourced separately. Installation details are provided in the Power Block 2000 *Installation Guide*.

Because the wiring requirement depends on the exact Power Link model—and the models are identified by product part number—[contact ChargePoint](#) to determine whether your project requires a Safety Hub twisted-pair connection or a jumper installation.

# Wiring and Conduit Requirements

Refer to the *Power Block 2000 Datasheet* at [ChargePoint Product Reference Documentation](#) for full product specifications.

Ensure that the installation location is equipped with service wiring that support the station's power requirements.

Conduit and wire size are determined based on current. Service wiring in conduit or armored cable must be run as required to comply with local electrical codes. Consult national and local codes or a project engineer to determine the grade, quality, and size of the conduit or cable.

## NOTE:



- All wiring and conduit is supplied by the contractor unless otherwise indicated.
- For V2G and energy storage applications, [contact ChargePoint](#) for wire and conduit requirements.

## Wire Run Lengths

Wire run length guidelines are given below:

- The maximum total external DC output wire run length from a Power Block 2000 to a connected EVSE (such as a Power Link 2000) must not exceed 200 m (656 ft). Refer to the cluster configuration provided by ChargePoint for interconnect details.
- 48 V DC wire and Ethernet run length between Power Block 2000 and a Power Link must not exceed 200 m (656 ft).
- At minimum, there must be one 48 V DC wire pair connecting from the Power Block 2000 to each Power Link. If the distance between the Power Block 2000 and a Power Link exceeds 100 m (328 ft), then two 48 V DC wire pairs must be run to compensate for voltage drop.

## Ethernet Requirements

Ethernet requirements are given below:

- For Ethernet communications between any two nodes (for example, between a Power Block 2000 and a Power Link):
  - For distances up to 100 m (328 ft): use outdoor-rated Cat6 Shielded Twisted Pair (STP) cable. Lesser grades of cable do not provide the required noise immunity.
  - For distances between 100 m (328 ft) and 200 m (656 ft): use the Paige OSP Shielded GameChanger cable (see [paigedatacom.com/gamechanger](http://paigedatacom.com/gamechanger)) or other extended-reach cable rated for 200 m (328 ft).
- An Ethernet cable run between a Power Block 2000 and a Power Link must have the shield terminated only at the Power Block 2000 end, not at the Power Link end.

## Conduit Requirements

In regions that use conduits, wire conduits may enter Power Block 2000 through a Concrete Mount Template (CMT) or through a skid via conduit stub-ups. In regions that do not use conduits and/or use armored cables, the cables may be laid per the conduit layout defined by the CMT.

If using conduits:

- Conduits must be sealed to maintain a Pollution Degree 2 environment.
- Conduits must not have bell ends. Conduits with bell ends may interfere with tolerances inside the Power Block 2000.
- If using conduit stub-ups (ie., not using surface conduit entry), conduits must stub-up 13–25 mm (0.5–1 in) above the mounting surface.

Below is a sample depiction of wire entry via conduit stub-ups.



**IMPORTANT:** Conduit and wire size and quantity are shown for illustrative purposes only. The actual quantity and size of conduits and wires for your specific site may vary and shall depend on site specific requirements.

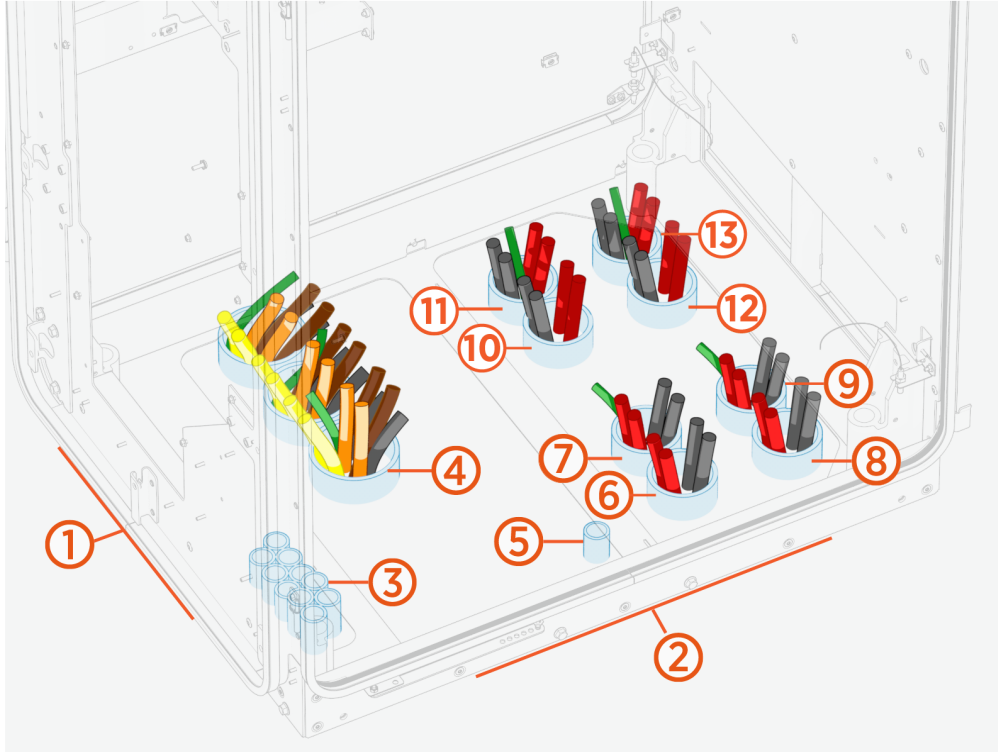

Ref	4 DC Output	8 DC Output
(1)	Cabinet front side	
(2)	Cabinet intake (right) side	
(3)	48 V DC, Ethernet, and Safety Hub	
(4)	AC input	
(5)	Shunt trip	
(6)	EXT A	EXT A
(7)		EXT B
(8)	EXT B	EXT C
(9)		EXT D
(10)	EXT C	EXT E
(11)		EXT F
(12)	EXT D	EXT G
(13)		EXT H



**IMPORTANT:** The following table provides the maximum size and quantity of conduits that can be installed on Power Block 2000 configured for standard wire entry. The actual conduit size and quantity must be chosen based on site specific wiring requirements. The outer diameter of the conduits must not exceed the maximum trade size specifications listed below.

Conduits For	Conduit Quantity x Trade Size
AC input	3 x 103 mm max.
External DC output (E.g. EXT A, EXT B, EXT C, EXT D)	1 x 103 mm max. per output or 2 x 78 mm max. per output
48 V DC, Ethernet, and Safety Hub *	1 x 27 mm to each Power Link 1 inch size conduit is required. The quantity of conduits will depend on the configuration.
Optional Features (Soft shutdown switch and shunt trip)	1 x 21 mm max. per feature

*\*48 V DC, Ethernet, and Safety Hub wires travel in the same conduit when connecting Power Block 2000 to a Power Link. Safety Hub wires are required for only for certain models of Power Link. [Contact ChargePoint](#) to determine if Safety Hub wiring is required for your specific project.*

## Wire Terminal and Bus Bar Locations



**NOTE:** This section illustrates terminal and bus bar locations for the Power Block 2000 in a 4 DC output configuration. Illustrations for 8 DC output and 12 DC output configurations will be provided in a future revision.

The following identifies the wire ports, terminals, and bus bars accessible from the intake side (right side) of each Power Block 2000 cabinet. (Safety shields are hidden from view.)

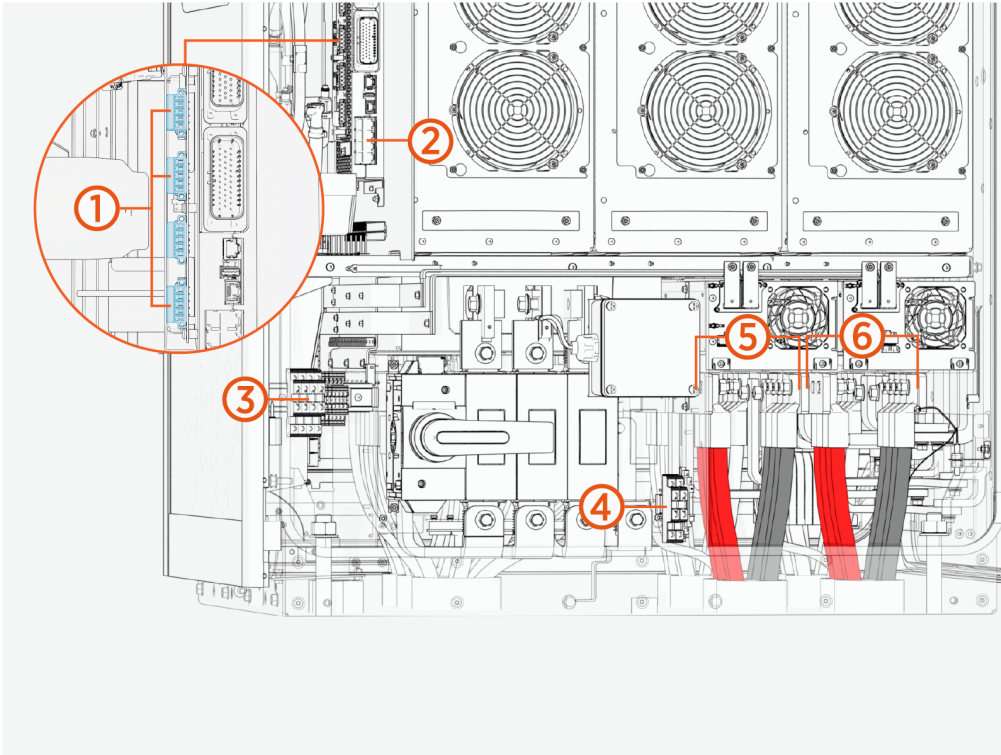

Ref	Part
(1)	Safety Hub ports
(2)	Ethernet ports
(3)	Terminal block for 48 V DC and soft shutdown switch wires
(4)	Shunt trip terminals
(5)	EXT A bus bars
(6)	EXT B bus bars

The following identifies the wire ports, terminals, and bus bars accessible from the exhaust side (left side) of each Power Block 2000 cabinet. (Safety shields are hidden from view.)

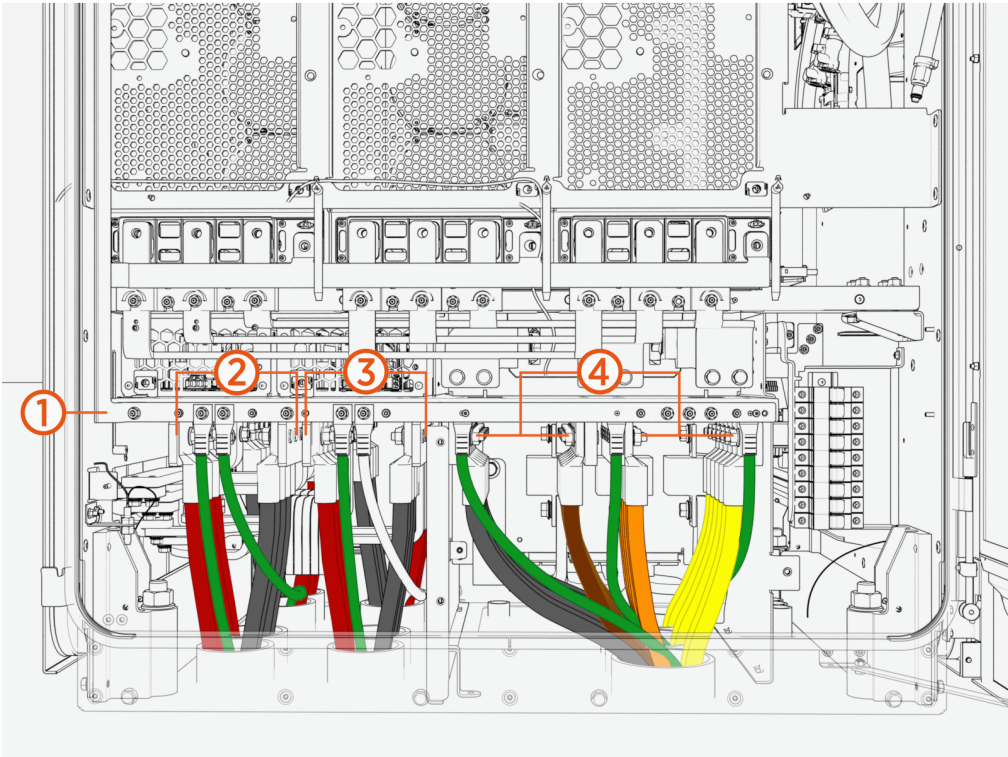

Ref	Part
(1)	Ground bar (with wire landing studs)
(2)	EXT D bus bars
(3)	EXT C bus bars
(4)	AC input (L1, L2, L3) and Neutral bus bars

## Wire Specifications

**IMPORTANT:** For AC input and external DC output (EXT A, EXT B, EXT C, EXT D, and so on) high current conductors, use copper or aluminum wires rated for 90 °C (194 °F).



- AC input conductors must be installed following international and/or national wiring codes such as IEC 60364 and be suitable for the installation environment (e.g., dry, damp, or wet locations).
- External DC output conductors (EXT A, EXT B, EXT C, EXT D, and so on) must use insulation suitable for at least 1000 V DC.
- Power Block 2000 is available in two factory configurations: with a Neutral landing or without one. A Neutral connection is not required for standard charging applications. However, some Vehicle-to-Grid (V2G) systems rely on phase-to-neutral voltage measurements for control functions. When planning a V2G deployment, [contact ChargePoint](#) to ensure the correct Power Block 2000 configuration is selected.
- For 48 V DC, shunt-trip, and Safety Hub wiring, use copper conductors only. Ensure the wire type is selected for suitability for the installation environment (e.g., dry, damp, or wet locations).
- Use shunt trip wiring that has a voltage rating equal to the voltage rating of the AC input wires selected for the site.
- For Safety Hub wires, use twisted wires with voltage rating equal to the voltage rating of the AC input wires selected for the site.
- All landing bus bars are nickel-plated. Use the proper type of lug based on the conductor and bus bar material.
- When using aluminum conductors, ChargePoint recommends applying an appropriate antioxidant compound when terminating into tin, nickel, or silver plated lugs, where required by local code or specified by the lug manufacturer.

**IMPORTANT:**



After pulling of wires, all AC input and external DC output wires must undergo insulation testing as outlined in the *High Voltage Wire Insulation Resistance Test Field Guide*.



**IMPORTANT:** Following are wire specifications for Power Block 2000, including the maximum quantity and size that the wire terminals can accommodate. All sizing assumes a maximum ambient temperature of 50 °C (122 °F). Where the maximum wire size is listed, the actual wire quantity and size must be chosen based on site-specific wiring requirements and in accordance with the maximum allowed conduit filling rate per local code.

Wire	Quantity	Size	Termination
AC Input	Max. 18 wires (six per phase)	Size based on max. current, <u>max conduit size</u> , and 200 mm wire bending space	Lug: Compression lug; short barrel and tongue with single hole sized for M12 stud Max. tongue width: 36 mm (1.3 in).
AC Ground (PE)	Max. 3 wires (1 per AC conduit)	Refer to local code for size	Lug: Short barrel and tongue with single hole sized for M6 stud
External DC outputs (E.g. EXT A, EXT B, EXT C, EXT D)	Max. 8 wires per output (four per pole)	Size based on max. current, <u>max conduit size</u> , and 200 mm wire bending space	Lug: Compression lug; short barrel and tongue with single hole sized for M12 stud. Max. tongue width: 36 mm (1.3 in).
High power ground	Max. 2 wires per DC output (1 per output conduit)	Refer to local code for size	Lug: Short barrel and tongue with single hole sized for M6 stud.
48 V DC output	Max 4 wires per connected Power Link (2 wire pairs; each pair has one wire per pole)	16 mm <sup>2</sup>	Stripped wire end
Ethernet	1 per connected Power Link 1 for hardwire Ethernet (if needed)	Outdoor-rated Cat6 STP*	RJ45 connector, shielded
Safety Hub	2 wires per connected Power Link**	2.5 mm <sup>2</sup>	Stripped wire end
Soft shutdown switch	2 wires	2.5 mm <sup>2</sup>	Stripped wire end
Shunt trip	2 wires	2.5 mm <sup>2</sup>	Stripped wire end

\*The required Ethernet cable type depends upon the cable run length. See [Ethernet Requirements](#).

\*\*Safety Hub is required only for certain models of Power Link.



**IMPORTANT:** The wire specifications above reflect what is supported by the Power Block 2000. When connecting to a Power Link charging dispenser, the actual wire gauges and quantities may be limited by the Power Link. Refer to the *Express Power Link Site Design Guide* for details.

For AC input, Power Block 2000 allows a maximum of 18 total current carrying conductors. If utilizing this wiring configuration, install spreader bars at the breaker or transformer to split the outputs across the high number of conductors.

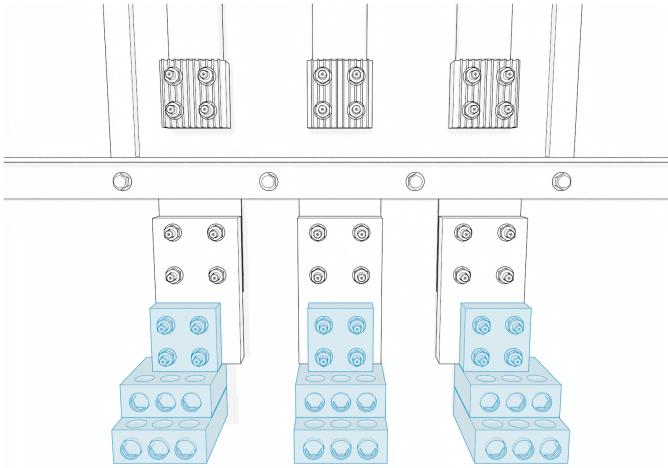

# Connectivity 5

A consistently strong cellular signal is needed before installers can activate the vehicle charging station. Weak or sporadic signal can affect crucial aspects of the charging station, including:

- Accuracy in reporting
- Ability for drivers to use the mobile app
- Ability for customer support to troubleshoot problems
- Support for advanced features such as Power Management or Waitlist

A strong signal is also required for the ChargePoint Assure maintenance and management programs.

ChargePoint stations use cellular data connections to reach ChargePoint Cloud Services. This allows secure, PCI-compliant data connections without requiring any other form of internet connectivity at an install site or imposing additional network management responsibilities on a site host.

Each station has its own cellular connection.

## Signal Strength and Quality

You must use a cellular signal detection device (such as a Siretta Snyder LTE or equivalent) to take signal strength readings at the exact proposed mounting location of the charging station. If the charging station does not have its own cellular connection, take the signal strength reading at the proposed mounting location of the gateway station.

In Europe, ChargePoint products all support LTE bands 1, 3, 7, 8, and 20. 900 and 1800 MHz are also supported for 2G fallback. Partners vary by country.

You must test the LTE signal strength at the proposed mounting location of every station and ensure the location meets the minimum RSRQ at -12.5 dB or better, for RSRP measured at -90 dBm or better. Refer to the graph for acceptable combinations.



**NOTE:** Cellular signal strength is measured in dBm, a logarithmic unit expressed as a negative number. Because dBm values are negative, a value closer to zero indicates a stronger signal. For example, -70 dBm represents a stronger signal than -85 dBm, while -90 dBm indicates a weaker signal than both.

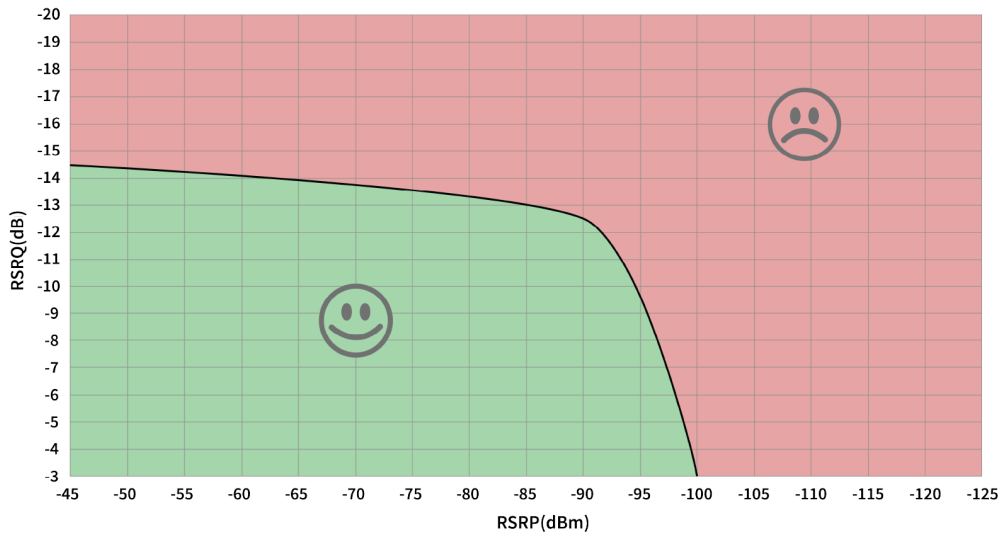

If the signal strength is weaker than this, take cellular readings at the location where any cellular signal booster antennas will be installed. Ensure enough signal exists for that repeater model. Install repeaters to boost the strength of the cellular signals. Repeaters are often required when installing charging stations in an underground garage or enclosed parking structure.

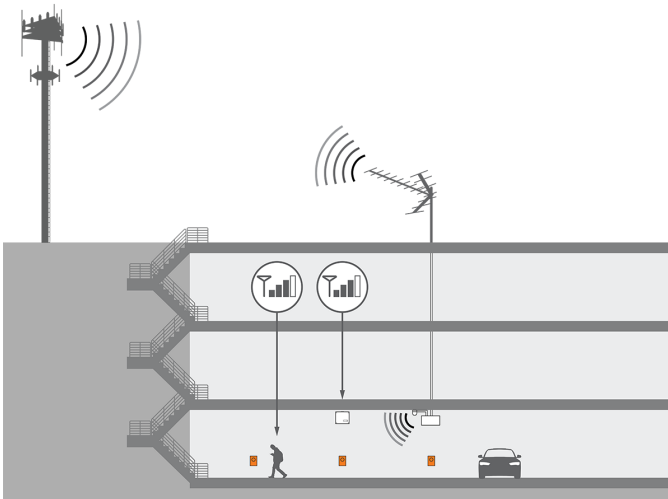
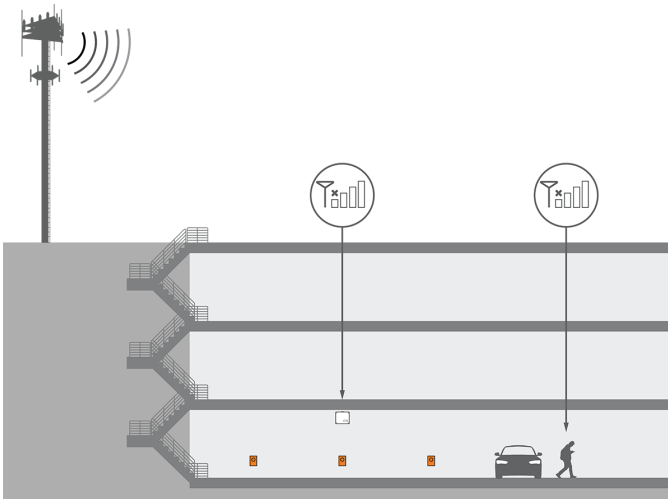

For other regions, or if the site does not have strong signal on these bands, contact your ChargePoint representative for additional solutions.

ChargePoint strongly recommends a consultation with a cellular connectivity specialist before all installations. A consultation can verify:

- Service with a supported carrier on a supported LTE band
- Available signal and local noise levels on applicable bands
- Site changes to correctly meet your needs, both for station bandwidth and other phone coverage for customer or tenant satisfaction

## Repeaters

Some sites require repeaters to ensure strong signal to all stations. If a repeater is required, look for a model with these features:

- Specifically LTE-compatible on the listed bands
- Multi-carrier
- Multi-band
- Not already dedicated to FirstNet or other first responder-specific networks
- Auto-gain recommended



**NOTE:** Do not rely on readings taken with a cell phone when conducting site surveys. Many signal boosters and network extenders may not be compatible with ChargePoint hardware, including certain types of Distributed Antenna Systems (DAS), micro/nano/pico/femto-cells, and carrier- or band-specific signal boosters.

Repeaters are not allowed in France. Contact the French service provider for more information.

## Limited Warranty Information and Disclaimer

The Limited Warranty you received with your charging station is subject to certain exceptions and exclusions. For example, your use of, installation of, or modification to, the ChargePoint® charging station in a manner in which the ChargePoint® charging station is not intended to be used or modified will void the limited warranty. You should review your limited warranty and become familiar with the terms thereof. Other than any such limited warranty, the ChargePoint products are provided "AS IS," and ChargePoint, Inc. and its distributors expressly disclaim all implied warranties, including any warranty of design, merchantability, fitness for a particular purposes and non-infringement, to the maximum extent permitted by law.

## Limitation of Liability

CHARGEPOINT IS NOT LIABLE FOR ANY DIRECT, INDIRECT, INCIDENTAL, SPECIAL, PUNITIVE OR CONSEQUENTIAL DAMAGES, INCLUDING WITHOUT LIMITATION LOST PROFITS, LOST BUSINESS, LOST DATA, LOSS OF USE, OR COST OF COVER INCURRED BY YOU ARISING OUT OF OR RELATED TO YOUR PURCHASE OR USE OF, OR INABILITY TO USE, THE CHARGING STATION, UNDER ANY THEORY OF LIABILITY, WHETHER IN AN ACTION IN CONTRACT, STRICT LIABILITY, TORT (INCLUDING NEGLIGENCE) OR OTHER LEGAL OR EQUITABLE THEORY, EVEN IF CHARGEPOINT KNEW OR SHOULD HAVE KNOWN OF THE POSSIBILITY OF SUCH DAMAGES. IN ANY EVENT, THE CUMULATIVE LIABILITY OF CHARGEPOINT FOR ALL CLAIMS WHATSOEVER RELATED TO THE CHARGING STATION WILL NOT EXCEED THE PRICE YOU PAID FOR THE CHARGING STATION. THE LIMITATIONS SET FORTH HEREIN ARE INTENDED TO LIMIT THE LIABILITY OF CHARGEPOINT AND SHALL APPLY NOTWITHSTANDING ANY FAILURE OF ESSENTIAL PURPOSE OF ANY LIMITED REMEDY.

## FCC Compliance Statement

Refer to the ChargePoint product nameplate to determine if your product is Class A or Class B.

- **Class A Statement:** This equipment has been tested and found to comply with the limits for a Class A digital device pursuant to Part 15 of the FCC Rules. These limits are designed to provide reasonable protection against harmful interference when the equipment is operated in a commercial environment. This equipment generates, uses, and can radiate radio frequency energy and, if not installed and used in accordance with the manufacturer's instruction manual, may cause harmful interference with radio communications. Operation of this equipment in a residential area is likely to cause harmful interference, in which case, you will be required to correct the interference at your own expense.

Important: Changes or modifications to this product not authorized by ChargePoint, Inc., could affect the EMC compliance and revoke your authority to operate this product.

Exposure to Radio Frequency Energy: The radiated power output of the 802.11 b/g/n radio and cellular modem (optional) in this device is below the FCC radio frequency exposure limits for uncontrolled equipment. The antenna of this product, used under normal conditions, is at least 20 cm away from the body of the user. This device must not be co-located or operated with any other antenna or transmitter by the manufacturer, subject to the conditions of the FCC Grant.

- **Class B Statement:** This equipment has been tested and found to comply with the limits for a Class B digital device, pursuant to part 15 of the FCC Rules. These limits are designed to provide reasonable protection against harmful interference when the equipment is operated in a residential installation. This equipment generates, uses, and can radiate radio frequency energy and, if not installed and used in accordance with the instruction manual, may cause harmful interference to radio communications.

Important: Changes or modifications to this product not authorized by ChargePoint, inc., could affect the EMC compliance and revoke your authority to operate this product.

Exposure to Radio Frequency Energy: The radiated power output of the 802.11 b/g/n radio and cellular modem (optional) in this device is below the FCC radio frequency exposure limits for uncontrolled equipment. The antenna of this product, used under normal conditions, is at least 20 cm away from the body of the user. This device must not be co-located or operated with any other antenna or transmitter by the manufacturer, subject to the conditions of the FCC Grant.

## ISED (formerly Industry Canada)

This device complies with the licence-exempt RSS standard(s) of Innovation, Science and Economic Development Canada (ISED). Operation is subject to the following two conditions: (1) this device may not cause interference, and (2) this device must accept any interference, including interference that may cause undesired operation of the device.

Cet appareil est conforme aux flux RSS exemptés de licence d'Innovation, Sciences et Développement économique Canada (ISDE). L'exploitation est autorisée aux deux conditions suivantes : (1) l'appareil ne doit pas produire de brouillage, et (2) l'utilisateur de l'appareil doit accepter.

Radiation Exposure Statement: This equipment complies with the IC RSS-102 radiation exposure limits set forth for an uncontrolled environment. This equipment should be installed and operated with a minimum distance of 20 cm between the radiator and your body.

Énoncé d'exposition aux rayonnements: Cet équipement est conforme aux limites d'exposition aux rayonnements ioniques RSS-102 Pour un environnement incontrôlé. Cet équipement doit être installé et utilisé avec un Distance minimale de 20 cm entre le radiateur et votre corps.

### **FCC/IC Compliance Labels**

Visit [chargepoint.com/labels](https://chargepoint.com/labels).