

Express Distro Power Link 2000

One Platform, Infinite Possibilities

Site Design Guide for North America



IMPORTANT SAFETY INSTRUCTIONS

SAVE THESE INSTRUCTIONS

This manual contains important instructions for ChargePoint® products that shall be followed during installation, operation and maintenance of each product.

WARNING:



1. **Read and follow all warnings and instructions before servicing, installing, or operating the ChargePoint® product.** Install and operate only as instructed. Failure to do so may lead to death, injury, or property damage, and will void the Limited Warranty.
2. **ChargePoint recommends that installation, commissioning, and break-fix services be performed by a licensed electrician who is also a ChargePoint-certified technician.** These systems operate at high voltage, and without strict adherence to safety protocols, proper protective equipment, and ChargePoint technical guides, there is significant risk to people, equipment, and the environment. Please ensure full compliance with all applicable local and national buildings, electrical, and safety codes.
3. **Always ground the ChargePoint product.** A touch current of >3.5 mA AC RMS is possible in case of a fault condition of loss of electrical continuity of the earthing conductor. Failure to ground the product can lead to risk of electric shock. The product must be connected to a grounded, metal, permanent wiring system, or an equipment grounding conductor shall be run with circuit conductors and connected to the equipment grounding terminal or lead on the Electric Vehicle Supply Equipment (EVSE). Connections to the EVSE shall comply with all applicable codes and ordinances.
4. **Install the ChargePoint product using a ChargePoint-approved method.** Failure to install on a surface that can support the full weight of the product can result in death, personal injury, or property damage. Inspect the product for proper installation before use.
5. **The product is not suitable for use in Class 1 hazardous locations, such as near flammable, explosive, or combustible vapors or gases.**
6. **Supervise children near this device.**
7. **Do not put fingers into the electric vehicle connector or connector adapter. Do not touch fingers to charging rails.**
8. **Do not use this product if any cable is frayed, has broken insulation, or shows any other signs of damage.**
9. **Do not use this product if the enclosure, the flexible output cable, the vehicle inlet, the electric vehicle connector, or the electric vehicle connector adapter is broken, cracked, open, or shows any other signs of damage. Do not use this product if internal parts are accessible, including wiring.**
10. **Wire and wire terminal information are provided in the ChargePoint product Site Design Guide and Installation Guide.**

11. **Torques for installation of wire terminals are provided in the ChargePoint product Installation Guide.**
12. **The ChargePoint product maximum operating temperature is 50 °C (122 °F).**
13. **Do not use an electric vehicle connector adapter with any charger or EV that is capable of exceeding the adapter's rated voltage of current capacity. Some EVs and EVSE combinations are capable of multiple voltages or limited durations of current overloading designed for normal EVSE-to-EV connections. Use of an electric vehicle connector adapter in these situations could result in unsafe conditions such as fire, burns, or exposure of high voltage.**



IMPORTANT: Under no circumstances will compliance with the information in a ChargePoint guide such as this one relieve the user of the responsibility to comply with all applicable codes and safety standards. This document describes approved procedures. If it is not possible to perform the procedures as indicated, contact ChargePoint. ChargePoint is not responsible for any damages that may result from custom installations or procedures not described in this document or that fail to adhere to ChargePoint recommendations.

Warranty Implication



IMPORTANT: Please be advised that all installation, commissioning, and break-fix services must be performed by a ChargePoint-certified technician. Engaging non-certified personnel for these services will result in warranty implications, as doing so constitutes a breach of policy.

Support Services

<https://www.chargepoint.com/legal/support-services>

For more information about ChargePoint's training and certification program, visit <https://www.chargepoint.com/partners/training-certification>

Product Disposal

Do not dispose of as part of unsorted domestic waste. Inquire with local authorities regarding proper disposal. Product materials are recyclable as marked.



Document Accuracy

The specifications and other information in this document were verified to be accurate and complete at the time of its publication. However, due to ongoing product improvement, this information is subject to change at any time without prior notice. For the latest information, see our documentation online at [ChargePoint Product Reference Documentation](#).

Copyright and Trademarks

©2013-2026 ChargePoint, Inc. All rights reserved. This material is protected by the copyright laws of the United States and other countries. It may not be modified, reproduced, or distributed without the prior, express written consent of ChargePoint, Inc. ChargePoint and the ChargePoint logo are trademarks of

ChargePoint, Inc., registered in the United States and other countries, and cannot be used without the prior written consent of ChargePoint.

Symbols

This guide and product use the following symbols:



DANGER: Risk of electric shock



WARNING: Risk of personal harm or death



CAUTION: Risk of equipment or property damage



IMPORTANT: Critical detail that must be followed to achieve intended results



NOTE: Important contextual details or procedural clarifications



REINSTALL NOTE: Essential instructions to follow when reinstalling a part or component



Read the manual for instructions



Ground/protective earth

Illustrations Used in This Document

The illustrations used in this document are for demonstration purposes only and may not be an exact representation of the product. However, unless otherwise specified, the underlying instructions are accurate for the product.

Contents

- IMPORTANT SAFETY INSTRUCTIONS i
- Revision History vi
- 1 Introduction 1**
 - About This Guide 1
 - Power Link 2000 Overview 1
 - Product Guides 12
 - Questions 12
- 2 Site Planning and Placement 13**
 - Initial Site Guidelines 13
 - Plan for Future Charging Capacity 13
 - System Placement 14
- 3 Civil and Mechanical Design 20**
 - Weights 20
 - Dimensions 21
 - Power Link 2000 Pedestal Mounting Specifications 27
 - Power Link 2000 Overhead Mounting Specifications 35
 - Drainage 39
 - Clearances 40
 - Wheel Stops and Bollards 41
 - Ventilation 42
 - Accessibility 43
 - Signage 43
- 4 Electrical Design 44**
 - Grounding Requirements 45
 - Power Link 2000 Soft Shutdown 45
 - DC Maintenance Switch 46
 - Sequential Charging Kit 46
 - Ethernet to USB Kit 46
 - Wiring and Conduit Requirements 46
 - Wire Terminal and Bus Bar Locations 49
 - Wire Specifications 52

5 Connectivity	54
Signal Strength and Quality	54
Repeaters	56

Revision History

This page provides a summary of revisions made, listing the month and year of each update along with a brief description of the changes made.

Month & Year	Description
June 2026	Early access draft - initial release.

Introduction 1

This section defines the purpose of this guide and provides an introduction to the ChargePoint® Power Link 2000.

About This Guide

This guide outlines the requirements and best practices for designing project sites that will host the ChargePoint Power Link 2000. It covers electrical infrastructure requirements, capacity planning, conduit and concrete work, site layout considerations, and cellular signal requirements needed to prepare a site for installation.

This guide is intended for site designers, electrical engineers, project planners, architects, and construction professionals responsible for preparing a site for Power Link 2000 deployment.



IMPORTANT: You must be a licensed electrician and complete online training to become a ChargePoint certified installer. If you do not complete training, you cannot access the ChargePoint network to complete installation. Find online training at: <https://www.chargepoint.com/partners/training-certification>. If the charging station is not installed by a ChargePoint certified installer, using a ChargePoint approved method, it is not covered under warranty and ChargePoint is not responsible for any malfunctions.

Power Link 2000 Overview

Power Link 2000 is a product within the Express DC fast charging platform. Power Link 2000 is a charging dispenser that delivers DC power to EVs through flexible, lightweight charging cables equipped with industry standard connectors such as CCS1, CCS2, CHAdeMO, MCS, and NACS. The Power Link 2000 can accommodate up to two charging cables to charge two electric vehicles simultaneously or sequentially.

Power Link 2000 requires input power from a power cabinet. For information on power cabinets and other modular EVSEs in the Express product family, refer to the Express platform documents at [ChargePoint Product Reference Documentation](#).

Cabinet Configurations

The Power Link 2000 is a vertical cabinet that is available in the following variants:

- **Pedestal-Mount Power Link 2000** – Designed for installation on a concrete ground surface. This variant includes charging cable holsters and an interactive display, and is available with either single or dual charging cables.
- **Overhead-Mount Power Link 2000** – Designed for installation on a wall or overhead structure (such as a gantry or ceiling-mounted support). This variant is also available with either single or dual charging cables.

Pedestal-Mount

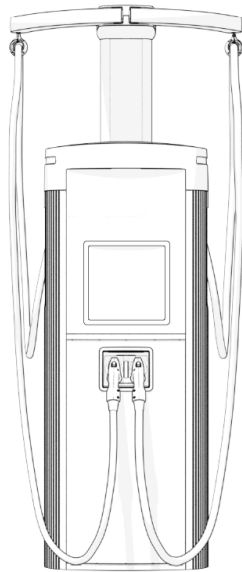

Overhead-Mount

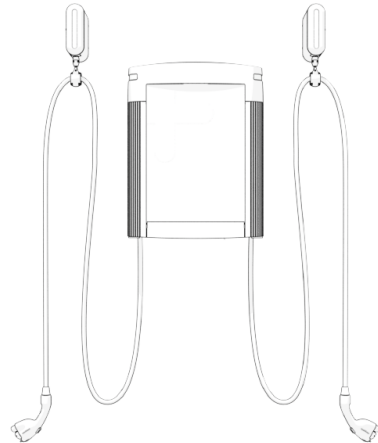

Charging Cable Type and Quantity

Depending on the charging speed and connectors required, pedestal-mount Power Link 2000s can be installed with one or two liquid-cooled cables (LCC) or non-liquid-cooled cables (non-LCC). The pedestal-mount Power Link 2000 with LCC comes with a liquid cooling system attached to the back of the enclosure.

Pedestal-Mount with Single or Dual LCC

Pedestal-Mount with Single or Dual Non-LCC

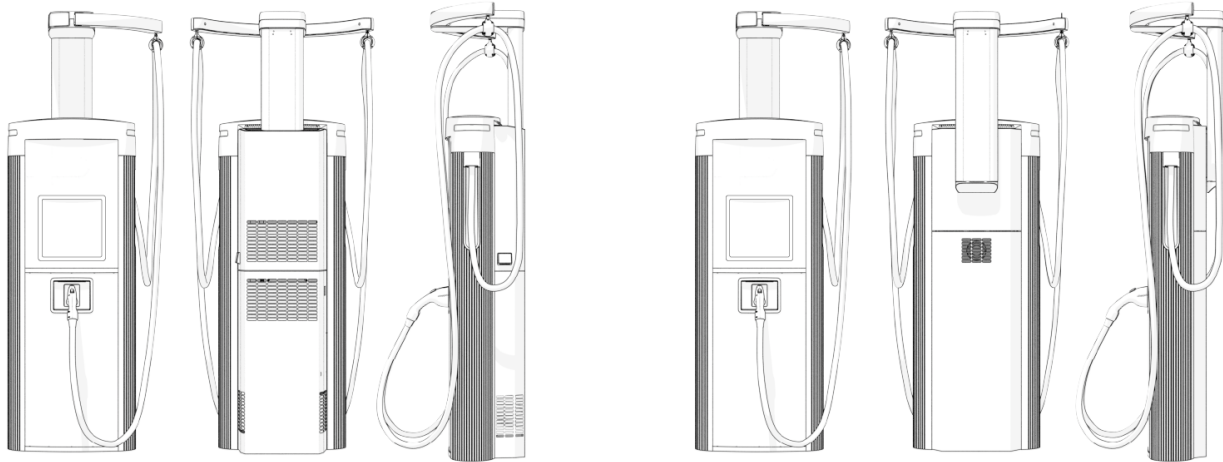

Charging Cable Length and Cable Management Kits

Depending on the required cable reach, the pedestal-mount Power Link 2000 can be installed with a standard cable management kit (CMK) to manage standard length (up to 5.8 m or 19 ft) charging cables, or with a tall CMK or overhead CMK to manage medium length (7.6 m or 25 ft) charging cables. The image below shows the CMK options installed with a pedestal-mount Power Link 2000.

Standard CMK

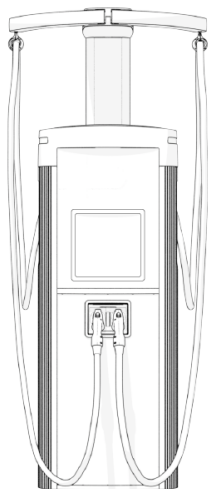

Tall CMK

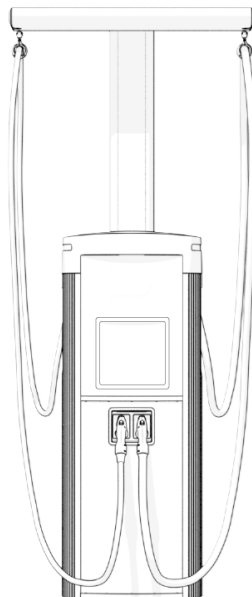

Overhead CMK

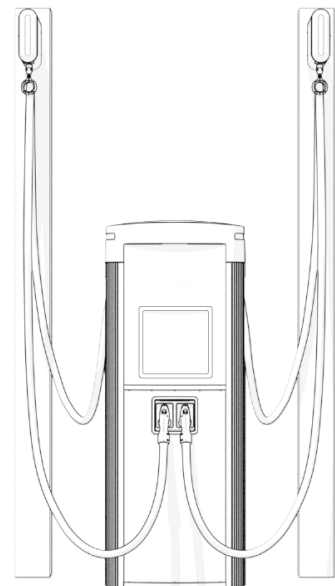

The CMKs function as follows:

- **Standard CMK** – Moveable arms on the CMK swing suspended charging cables out and forward for charging and retract cables to rest position between charges. The standard CMK is available with single or dual swing arms.

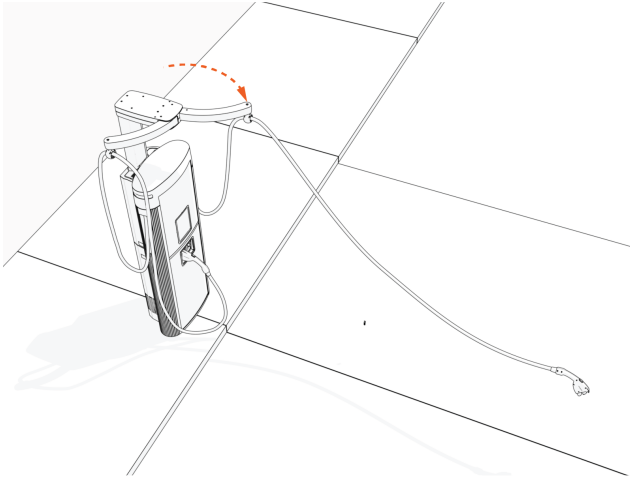

- **Tail CMK** – A tether cord extends out of the CMK as the suspended charging cable is pulled out and forward for charging. The tether cord retracts when the cable is returned, keeping the cable off the ground throughout use.

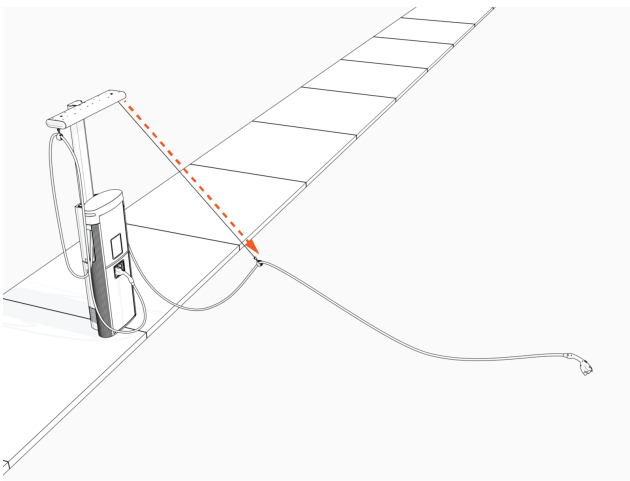

- **Overhead CMK** – The CMK suspends charging cables and uses a retractable tether cord to support the cable as it is pulled toward the vehicle and to lift it back to its rest position when released.

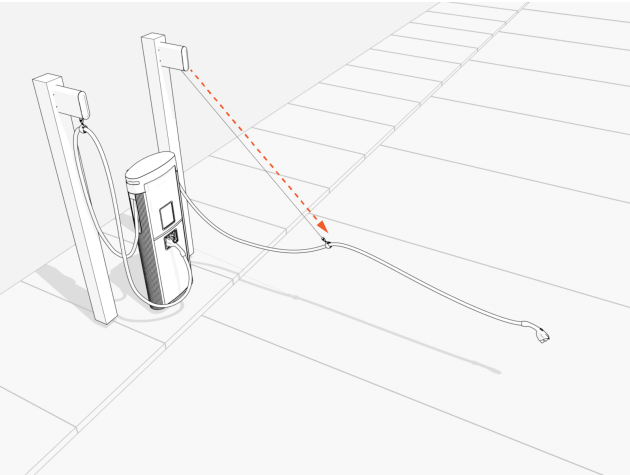

Exterior Parts

The following shows an exterior view of a Power Link 2000 equipped with a standard CMK.

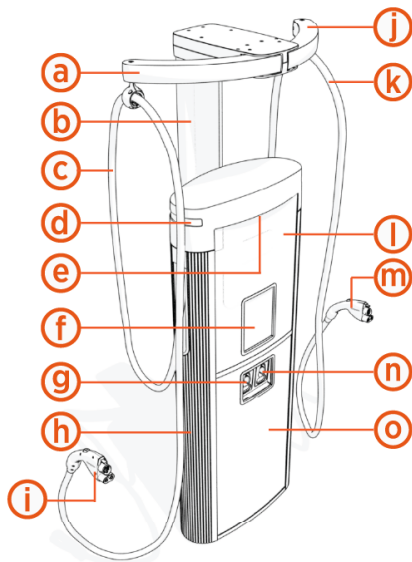

Front View

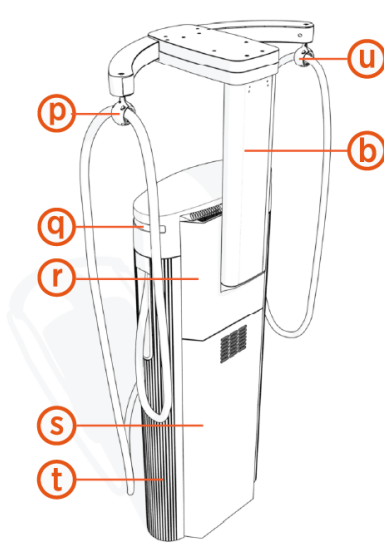

Rear View (non-LCC)

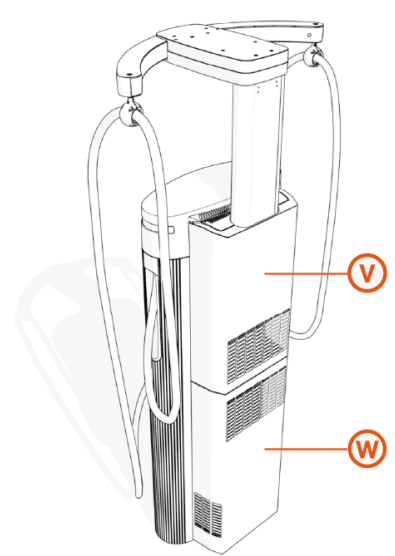

Rear View (LCC)

Ref	Part	Ref	Part
(a)	Standard CMK swingarm, left	(m)	Charging connector, right
(b)	Standard CMK mast	(n)	Holster, right
(c)	Charging cable, left	(o)	Lower cover and door (with customizable vinyl)
(d)	Status LED, left	(p)	Tetherball, right
(e)	Area downlight (front – illumination side)	(q)	Status LED, right
(f)	Display/CCOM assembly (display side)(*)	(r)	Upper rear cover (non-LCC)
(g)	Holster, left	(s)	Lower rear cover (non-LCC)
(h)	Side panel (side extrusion), left	(t)	Side panel (side extrusion), right
(i)	Charging connector, left	(u)	Tetherball, left
(j)	Standard CMK swingarm, right	(v)	Upper rear cover (LCC)
(k)	Charging cable, right	(w)	Lower rear cover (LCC)
(l)	Upper cover and door (with customizable vinyl)		



NOTE: (*) CCOM = Communications and Control Module

Interior Parts

The following shows an interior view of the Power Link 2000, with covers and panels removed.

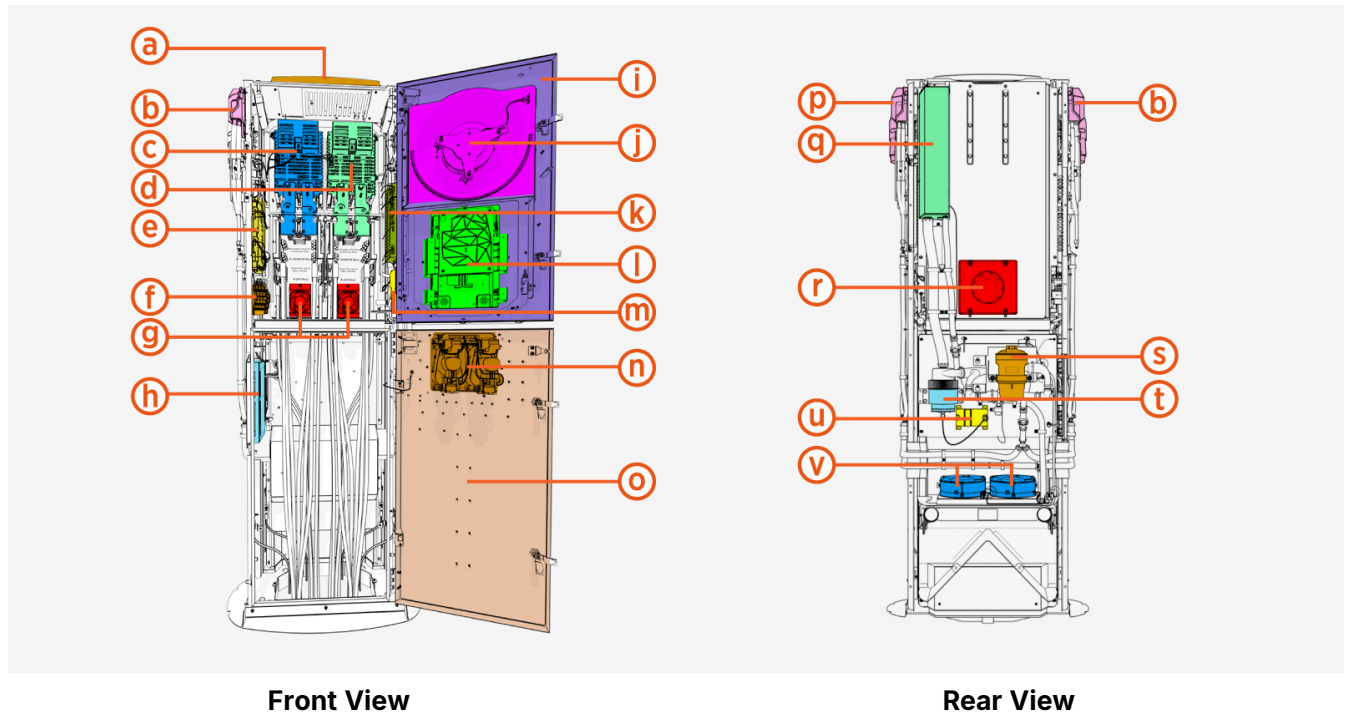

Ref	Part	Ref	Part
(a)	Smart antenna (option)	(l)	Display/CCOM Assembly (CCOM side)
(b)	Charging cable assembly, left	(m)	Smart Ethernet Switch
(c)	DC Input Power Path Assembly A(*)	(n)	Holsters, interior view
(d)	DC Input Power Path Assembly B(*)	(o)	Lower enclosure door
(e)	Power Link 2000 controller	(p)	Charging cable assembly, right
(f)	Terminal block (48 V DC and soft shutdown switch)	(q)	Coolant reservoir (LCC units only)
(g)	Internal fans	(r)	External fan
(h)	Cooling controller (LCC units only)	(s)	Ion filter (LCC units only)
(i)	Upper enclosure door	(t)	Pump (LCC units only)
(j)	Door fan	(u)	Pump controller (LCC units only)
(k)	Ethernet switch (SSLAN)	(v)	LCC fans (LCC units only)



NOTE: (*) Each power path assembly consists of a Proton module coupled with input/output bus bars.

System Description

The Power Link 2000 is a single-port or dual-port DC charging dispenser designed to interface with upstream ChargePoint Express power cabinets such as Express Solo or Power Block 2000.

The Power Link 2000 is equipped with up to two independent DC power paths:

- **Power Path A** – serves the left charging point
- **Power Path B** – serves the right charging point

Each power path may be configured to receive DC power from an upstream power cabinet and uses internal switching components to safely connect or disconnect power to each charging cable.

The Power Link 2000 also receives 48 V DC auxiliary power from the upstream cabinet's Auxiliary Power Supply (AUX PS). This power supports control electronics, communication hardware, UX systems, and sensor and safety circuits.

In addition, the Power Link 2000 maintains Ethernet communication with the upstream power cabinet for coordination, monitoring, and control.

The Power Link 2000 features an integrated control and safety system:

- **Power Link 2000 Controller** – An isolated power-control board with some auxiliary interface functions.
- **Protons** – Each power path utilizes a Proton module that contains switching elements for connecting or isolating the EV from the incoming DC supply. The Proton also provides integrated DC metering for monitoring voltage and current delivered to the EV. It enables the Power Link 2000 to safely energize the EV only after the charging handshake is complete, and it opens safely during faults, door-open events, or shutdown conditions. The Proton also allows for the same DC power to be connected to multiple power paths in sequential charging applications.
- **Control and Communication Module (CCOM)** – This module manages local user-experience hardware, communication interfaces, and connectivity functions within the dispenser. The CCOM supports the display, authentication hardware, status indicators, and other UX components, and it provides the communication link between the Power Link 2000 Controller and external systems.

The Power Link 2000 provides an integrated user interface for EV drivers, including a high visibility display, authentication hardware (e.g., RFID reader, credit card reader), LED status indicators, and a cable management system.

System Interfaces and Sample Architectures

This section provides a high-level overview of the electrical interfaces of a Power Link 2000. The interfaces are illustrated within the context of a few example architectures in which the Power Link 2000 is deployed with upstream power cabinets or in power pass-through configuration.

Below is an example architecture in which an Express Solo power cabinet serves a single Power Link 2000. For further details on Express Solo interfaces, refer to the *Express Solo Site Design Guide*.

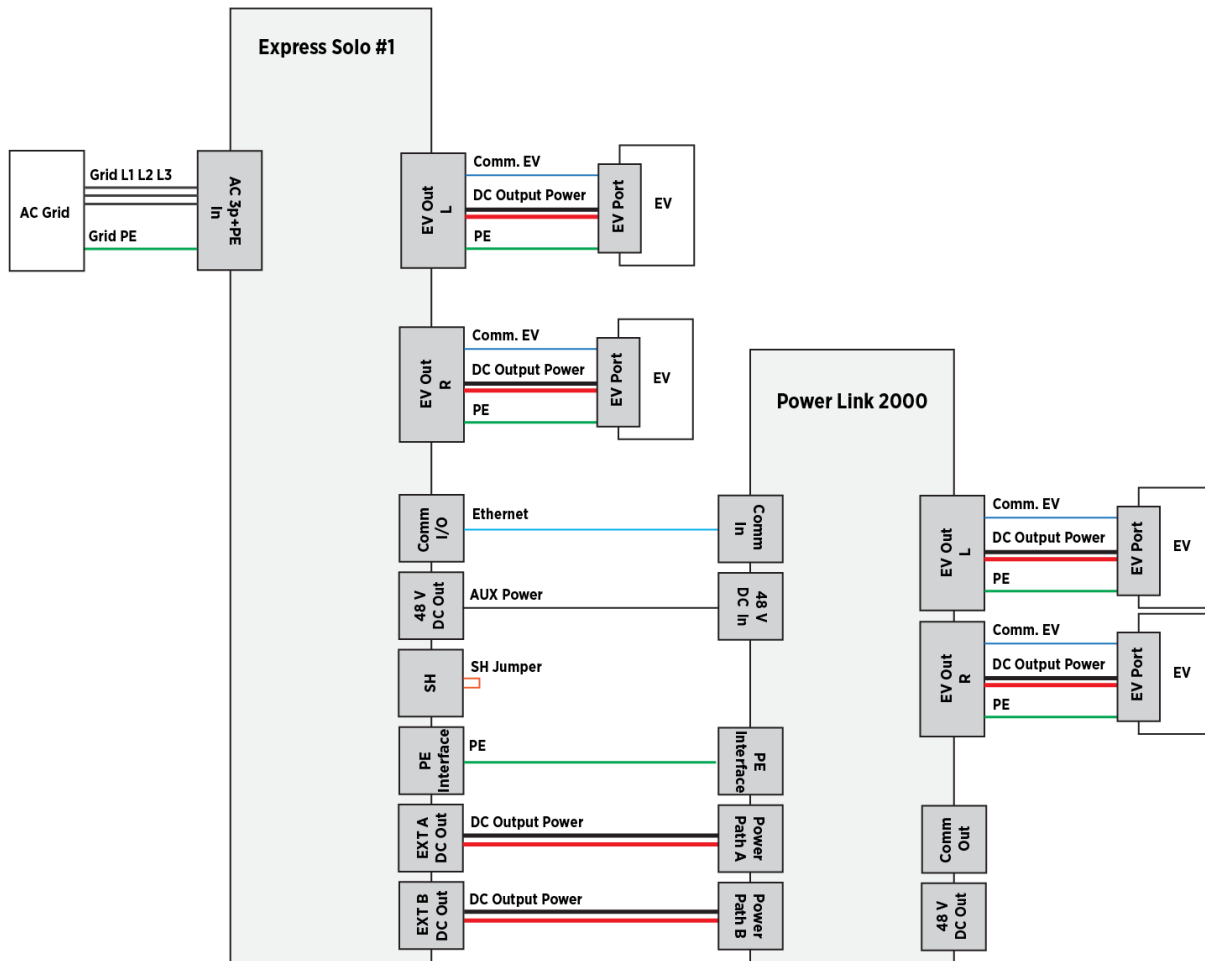

The next diagram shows a configuration in which a Power Block 2000 power cabinet supplies two Power Link 2000 dispensers. For further details on Power Block 2000 interfaces, refer to the *Express Distro Power Block 2000 Site Design Guide*.

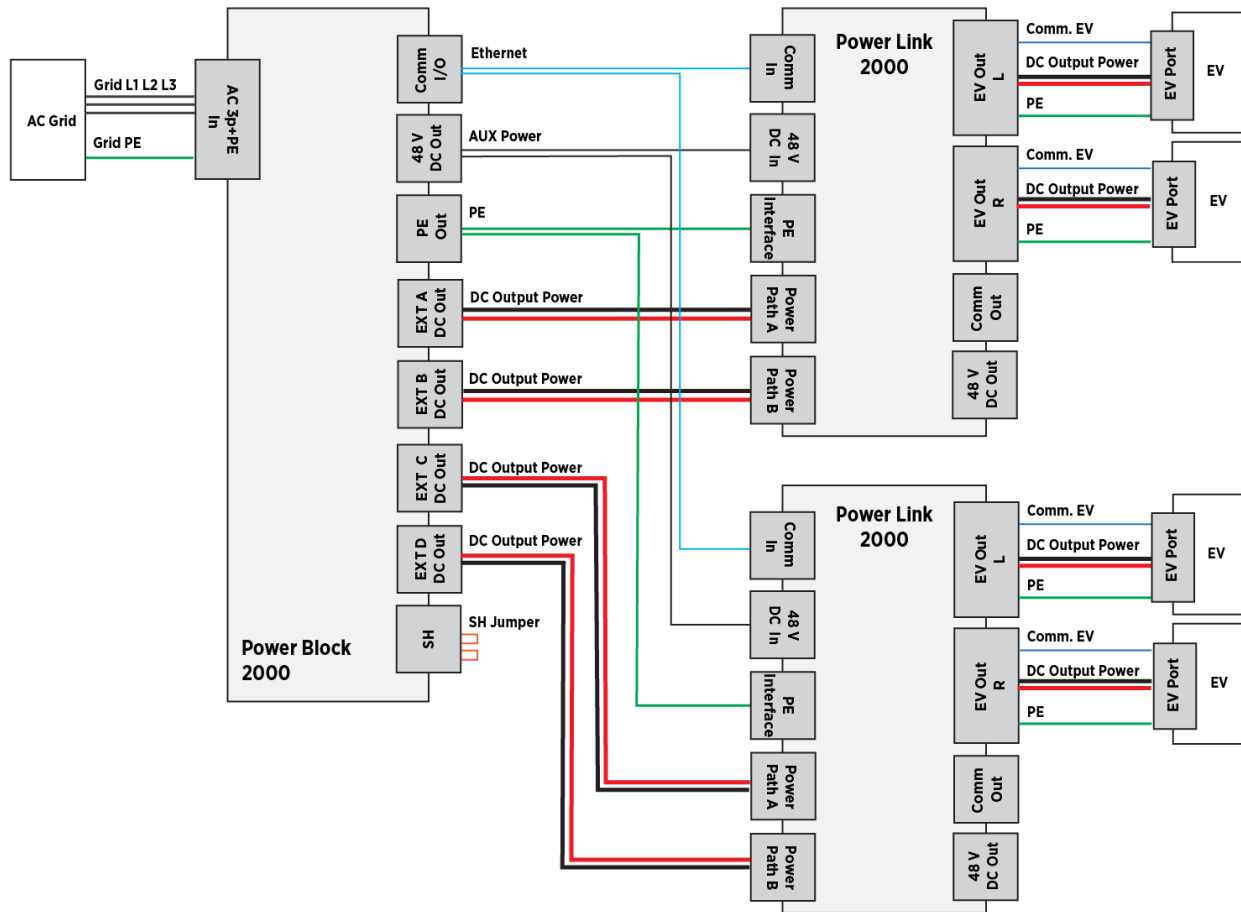

In certain system configurations, Ethernet and 48 V DC auxiliary power from an upstream power cabinet shall be connected from one Power Link 2000 to another, an arrangement known as daisy-chaining.

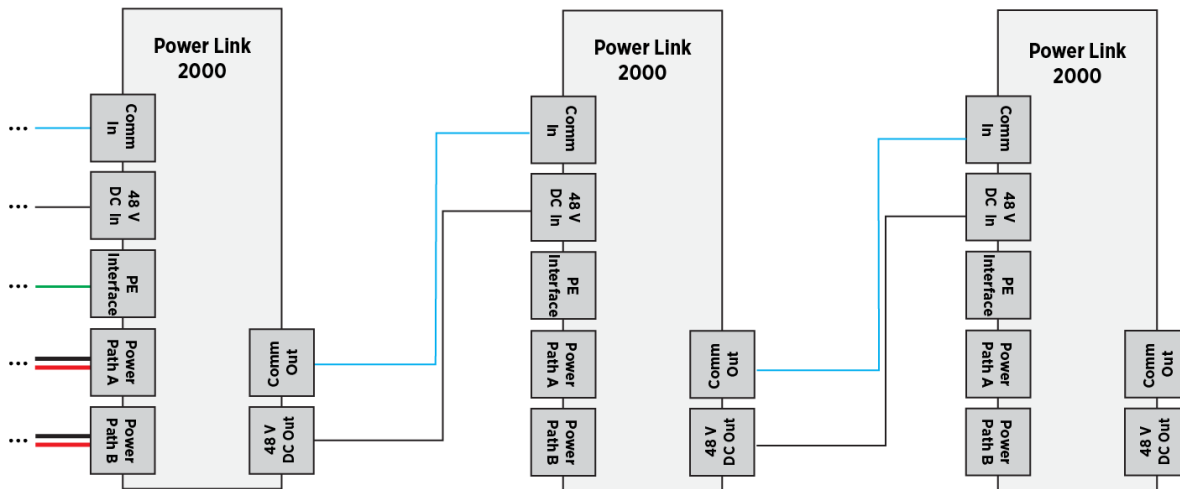

IMPORTANT: Power Link 2000 can be configured in many different system architectures, only a few of which are shown above. The actual architecture for each site will vary depending on the number of stations, the charging capacity required at each charging station, charging requirements, and other criteria. If you are a site designer, contact a ChargePoint representative for the ChargePoint-approved wiring architecture for your specific project. Systems configured with non-approved wiring between Power Link 2000 and connected EVSEs may not function as expected. If you are an installer, see the site plan for the architecture specific to the site installation project.

Product Guides

A full suite of guides is available for Power Link 2000, as summarized below.

Document	Content	Primary Audiences
Datasheet	Full station specifications	Site designer, installer, and station owner
Site Design Guide	Civil, mechanical, and electrical guidelines to scope and construct the site	Site designer, responsible engineer, contractors, installers
Construction Signoff Form	Checklists used by contractors to ensure the site is correctly completed and ready for product installation	Site construction contractor
Installation Guide	Anchoring, wiring, and powering on	Installer
Operation and Maintenance Guide	Operation and preventive maintenance information	Station owner, facility manager, and technician
Service Guide	Component replacement procedures, including optional components	Service technician
Declaration of Conformity	Statement of conformity with directives	Purchasers and public

Access ChargePoint documents at [ChargePoint Product Reference Documentation](#).

Questions

For assistance, go to chargepoint.com/support and contact technical support using the appropriate region-specific number.

Site Planning and Placement **2**

This section outlines general planning and placement requirements for Power Link 2000 sites.

Initial Site Guidelines

An onsite evaluation is needed to determine the wiring and conduit requirements from the electrical panel to the proposed parking spaces, as well as to measure cellular signal levels and identify suitable locations for any necessary cellular signal booster equipment.

If you have pre-existing infrastructure or are using your own preferred electrical contractor to prepare your site, a *Power Link 2000 Construction Signoff Form* completed by a ChargePoint Operations and Maintenance (O&M) partner is required to certify compliance with electrical code and to ensure everything was prepared to ChargePoint specifications.

Plan for Future Charging Capacity

Designing electrical infrastructure to support current and future needs for EV charging helps avoid costly upgrades later as demand for EV charging grows.

Consider these methods to prepare a site for future charging stations in a later phase of work:

- Add extra capacity if electrical panels are being upgraded now.
- Use sub-panels as a way to shorten electrical paths.
- Maximize the conduit and conductor sizes (to product specifications) between the main electrical panel and future stations to prevent needing to re-pull wires or trenching work if the site uses underground wiring.
- Underground service wiring conduits can be pre-staged if the correct site construction is performed in advance. Allowed terminations include a distribution unit, junction box, or plugged conduit. This eases cable pulls for future stations.

System Placement

The placement of Power Link 2000 must meet the following requirements:

- Do not install Power Link 2000 in a Class 1 hazardous location, as classified by NEC or local codes.
- Site conditions must be compatible with the following specifications listed in the *Express Power Link 2000 Datasheet*:
 - Operational altitude
 - Operating temperature
 - Operating humidity
 - Enclosure rating

To minimize costs, choose station locations that are close to the available electrical infrastructure. Selecting nearby locations help minimize long wire runs as well as any conduit or trenching work if the site uses underground wiring.



WARNING: Power Link 2000 must be installed on a structure that is rated to support its weight. A level concrete base is recommended for pedestal-mount Power Link 2000 and a flat wall or gantry is recommended for overhead-mount Power Link 2000. Asphalt cannot support the full weight of Power Link 2000. Failure to install the Power Link 2000 on a suitable structure may cause it to tip over, resulting in death, personal injury, or property damage.

Layout considerations:

- Determine appropriate ground anchoring locations where concrete exists or can be installed (no asphalt surfaces).
- Consider locations where it will be easy to add future stations.
- If using conduits to pull wires, determine the best conduit layout to minimize linear conduit costs to multiple parking spaces. If possible, avoid or minimize trenching requirements, especially more costly trenching to run conduit under asphalt surfaces.
- Determine if the existing utility service and electrical panel capacity is sufficient. Identify costs for any necessary upgrades and/or a new dedicated electrical panel. ChargePoint recommends using a licensed electrician to evaluate available capacity and identify any upgrades that may be required.
- If a dedicated EV electrical panel is required, choose a panel located close to the existing electrical supply.
- Measure cellular signal levels to ensure adequate cellular coverage at the station locations. To ensure adequate signal strength in underground or enclosed parking structures, cellular repeaters may be required. For more information, see [Connectivity](#).
- ChargePoint recommends avoiding locations under trees where sap, pollen, or leaves would fall on the charging station and increase the station owner's site maintenance workload.

Guidelines for Different Parking Arrangements

- Choose adjacent parking spaces in an area with adequate lighting.
- Consider how easily drivers can find the stations they need to access.
- Check local requirements for accessibility and pathway width, sometimes called “path of travel”, to ensure that station placement does not restrict sidewalk use.
- A pad built into the head of a parking space (instead of on the sidewalk) is allowed if local code allows it compared to the minimum parking space length, and the pad meets all pad requirements listed in this document.

Cable reach

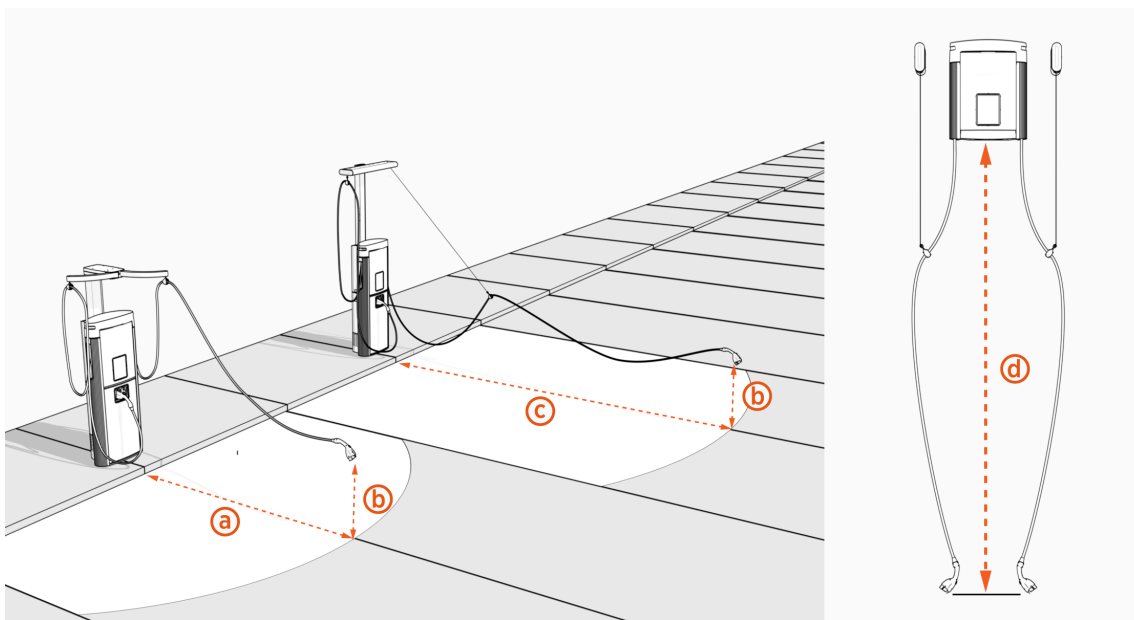

The following table provides the maximum cable reach from the station to charge port on a vehicle:



NOTE: The cable reach specifications for both the tall CMK and overhead CMK include the full extension of a tether cord from the CMKs, as depicted in the illustration above.

		Pedestal-mount Power Link 2000		Overhead-mount Power Link 2000
CMK		Standard CMK	Tall CMK	Overhead CMK
Cable length		LCC: 5 m (16.4 ft) Non-LCC: 5.8 m (19 ft)	7.6 m (25 ft)	7.6 m (25 ft)
Cable reach	Horizontal or vertical reach	3.76 m (12 ft 4 in) Horizontal (a)	6.09 m (20 ft) Horizontal (c)	4.57 m (15 ft) Vertical (d)
	Height above ground	0.6 m (2 ft) (b)		Not applicable

IMPORTANT:



- Diagonal stall parking is not recommended.
- Place each Power Link 2000 to maximize cable reach for the varied charge port locations on different EVs.

Commercial or Public Station Placement, Single or Dual Cable

For stall parking, ChargePoint recommends using perpendicular parking stalls that allow a vehicle to enter either front-first or rear-first, to better accommodate the varied locations of EV charge ports.



NOTE: While ChargePoint tests charging stations with a majority of upcoming vehicles, ChargePoint cannot guarantee the port locations of future vehicles and cannot warrant the configurations proposed will work for all vehicles.

This illustration depicts a charging station with a dual cable.

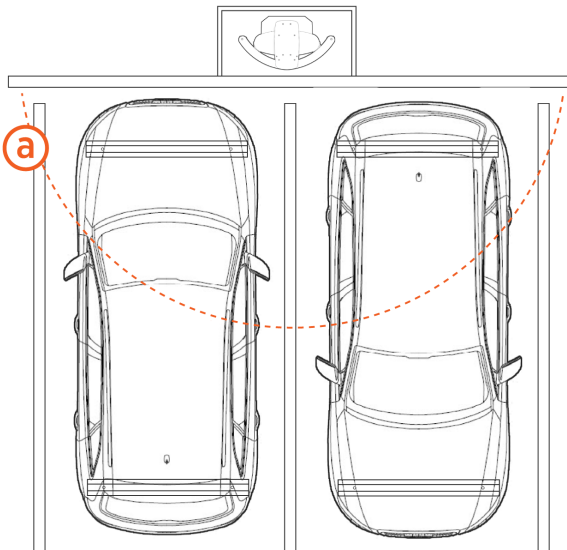

(a) Cable reach radius: 3.76 m (12 ft 4 in)

The following three illustrations depict charging stations with single cables.

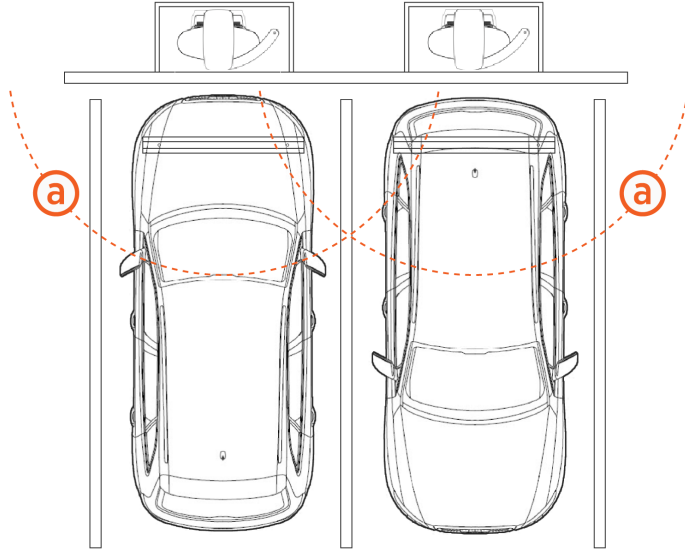

(a) Cable reach radius: 3.76 m (12 ft 4 in)

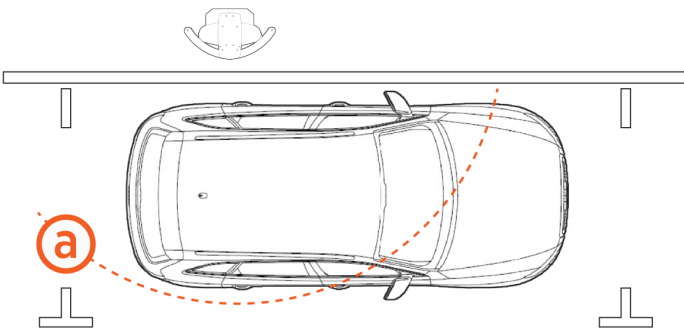
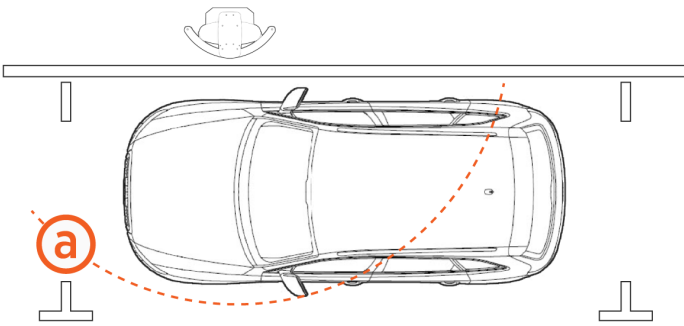

(a) Cable reach radius: 3.76 m (12 ft 4 in)

Fleet Parking Arrangement

- **Stall parking (Dual Charge Cable):** For installing dual charge cable Power Link 2000 stations, consider placing the station in front of every other parking space. Additionally, align the overhead CMK tether with the parking stripes on either side of the charging station.

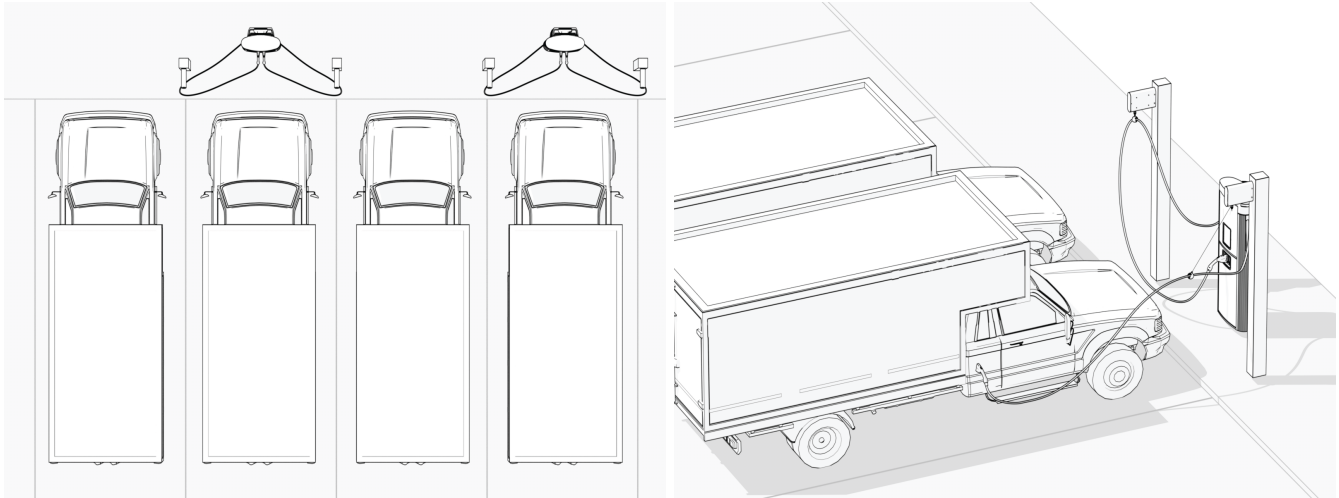

- **Stall parking (Single Charge Cable):** Power Link 2000s with single charging cables are always configured with the charging cable on the right side of the enclosure. Align the overhead CMK tether with the parking stall stripe adjacent to the vehicle's charging port. The illustrations below depict parking of the vehicles in relation to the charging stations, based on the side where the vehicle's charging port is located.

Vehicles with left-side charging ports

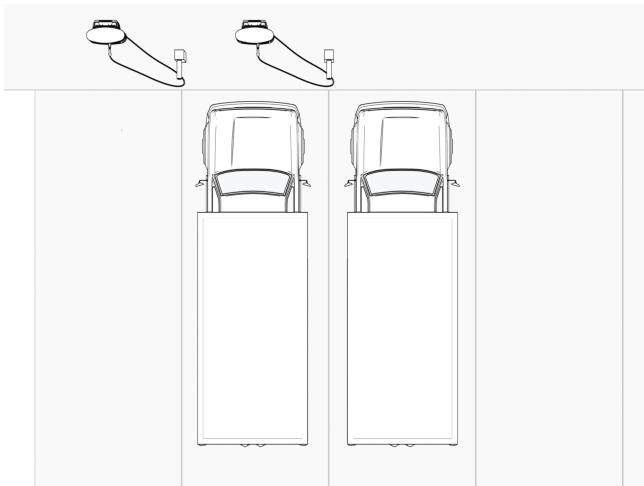

Vehicles with right-side charging ports

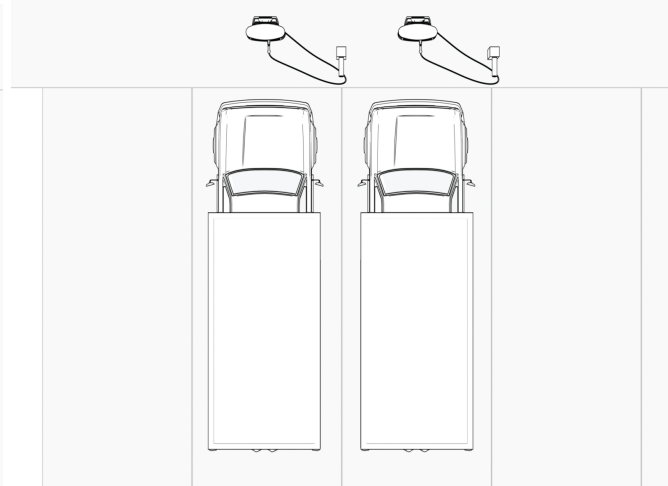

- **Island parking:** ChargePoint recommends placing a station in the center of the island facing away (station front is perpendicular to vehicles) in the same orientation. This allows the station to be accessible from both sides of the island.

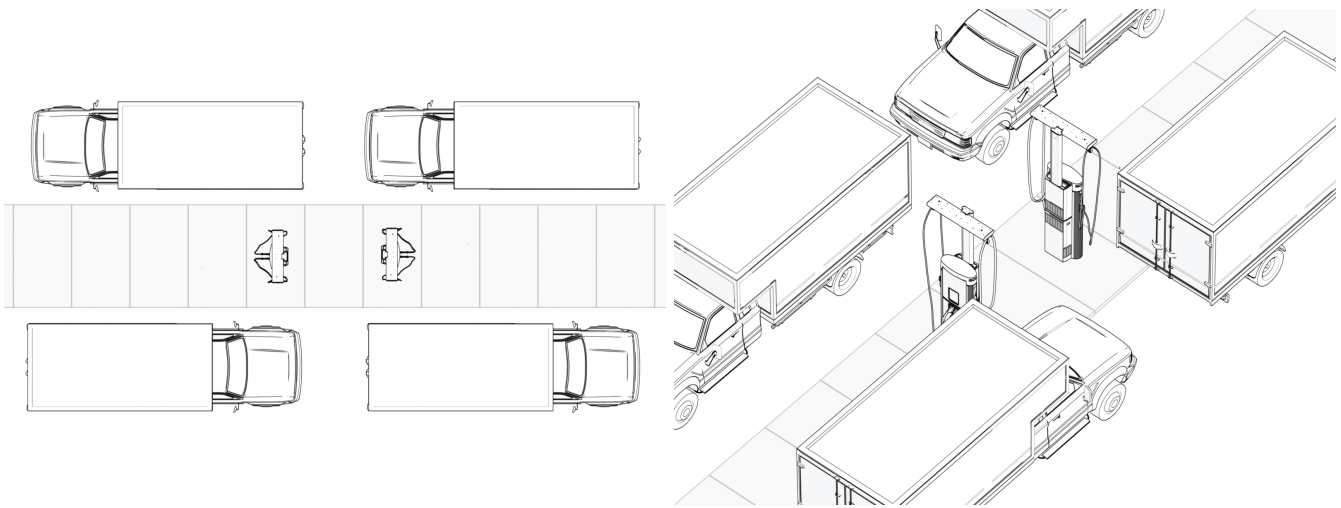

Civil and Mechanical Design 3

This section provides civil and mechanical site design information for Power Link 2000.

Weights

Component	Weight
Power Link 2000 - overhead-mount (excludes charging cables and CMK)	120 kg (265 lbs)
Power Link 2000 - pedestal-mount with LCC (excludes charging cables and CMK)	200 kg (441 lbs)
Power Link 2000 - pedestal-mount with non-LCC (excludes charging cables and CMK)	180 kg (400 lbs)
Charging cable	16 - 37 kg (35 - 82 lbs)
Standard CMK - dual	20 kg (44 lbs)
Tall CMK - dual	38.5 kg (85 lbs)
Overhead CMK	10 kg (22 lbs)
Packaging excluded from weights listed above	45 - 90 kg (100-200 lbs)

Dimensions

This section provides the dimensions of the Power Link 2000 in various configurations.

Pedestal-Mount Power Link 2000 With LCC, Single or Dual Cable, and Standard CMK



NOTE: Images are not to scale. Measurements appear in metric units (mm) followed by imperial equivalents (inches).

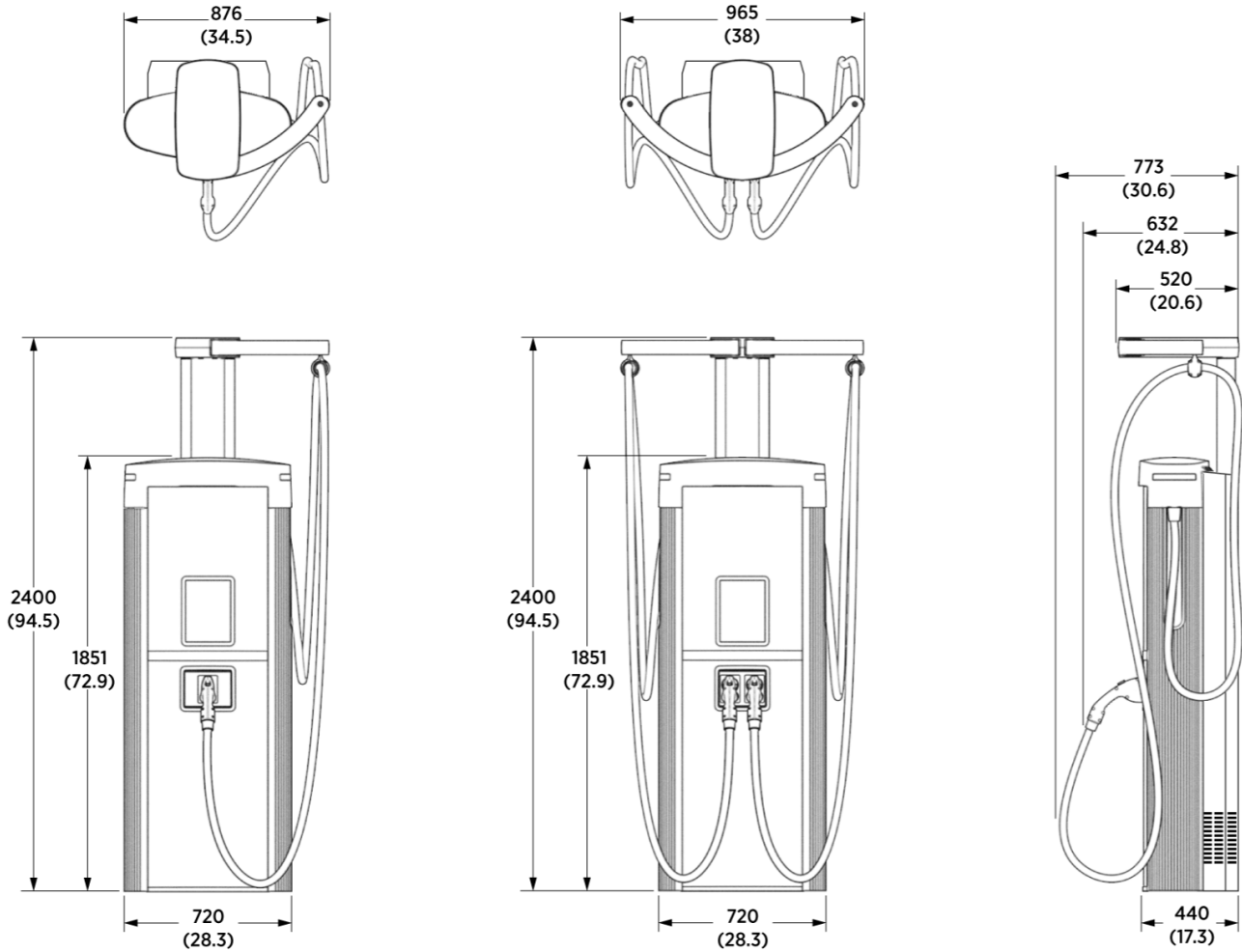

Pedestal-Mount Power Link 2000 With Non-LCC, Single or Dual Cable, and Standard CMK



NOTE: Images are not to scale. Measurements appear in metric units (mm) followed by imperial equivalents (inches).

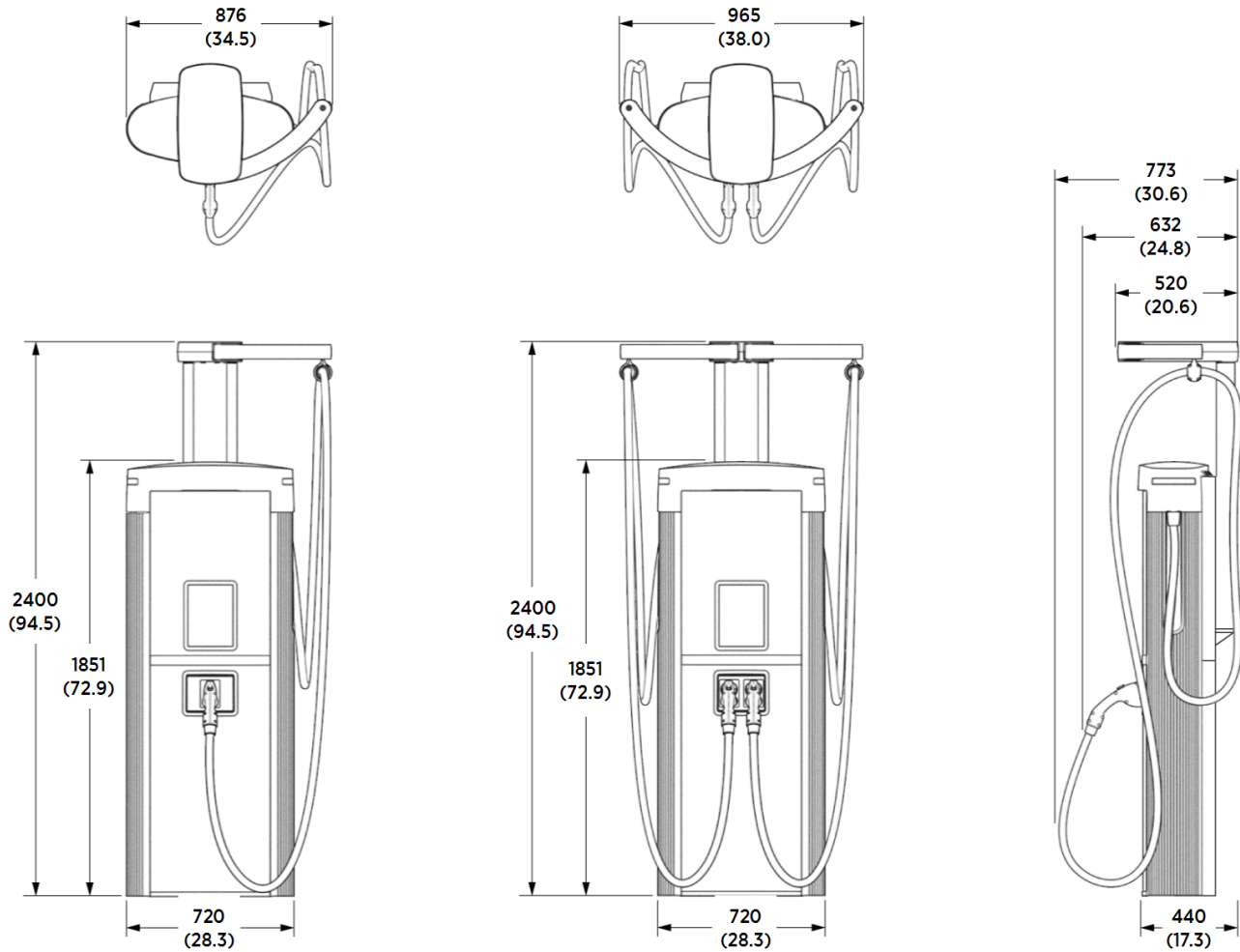

Pedestal-Mount Power Link 2000 With Non-LCC, Single or Dual Cable, and Tall CMK



NOTE: Images are not to scale. Measurements appear in metric units (mm) followed by imperial equivalents (inches).

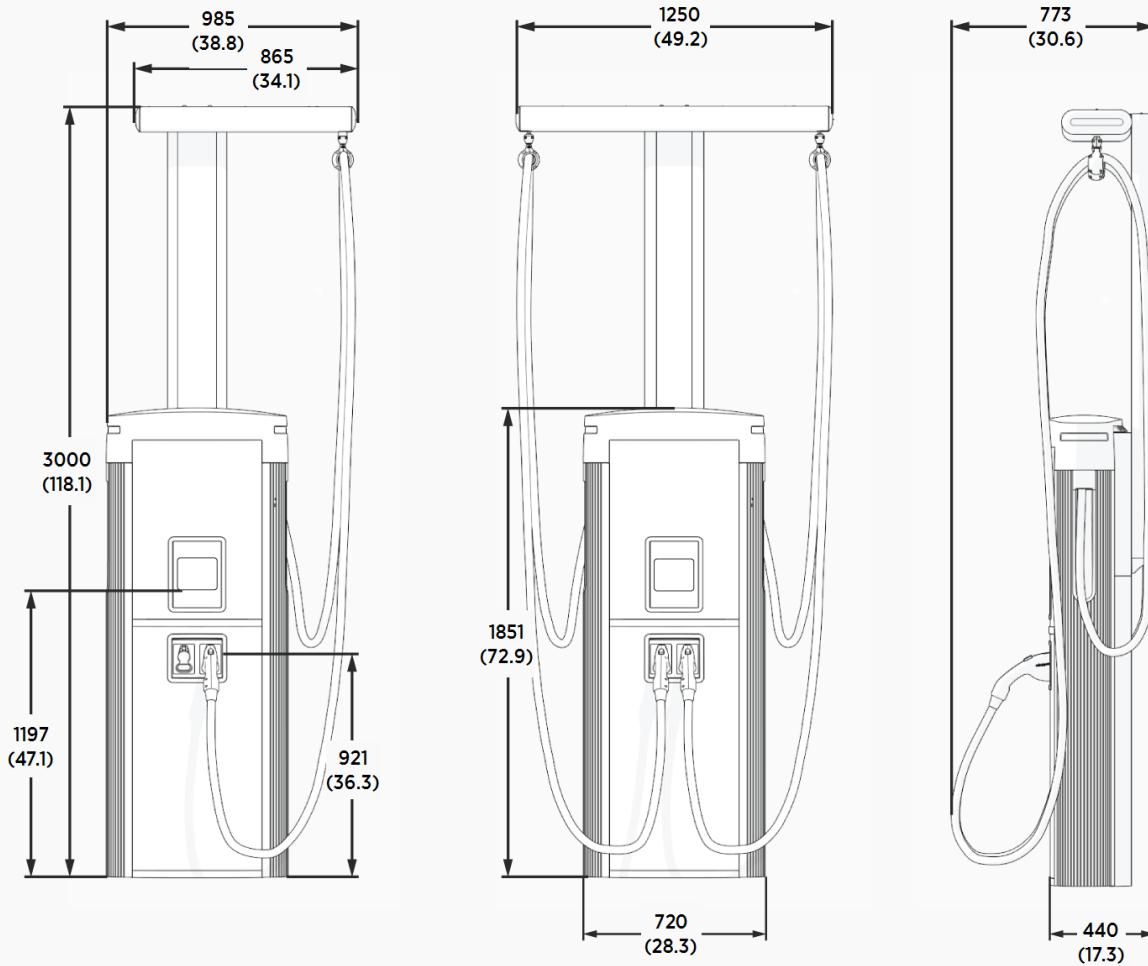

Pedestal-Mount Power Link 2000 With Non-LCC, Single or Dual Cable, and Overhead CMK



NOTE: Images are not to scale. Measurements appear in metric units (mm) followed by imperial equivalents (inches).

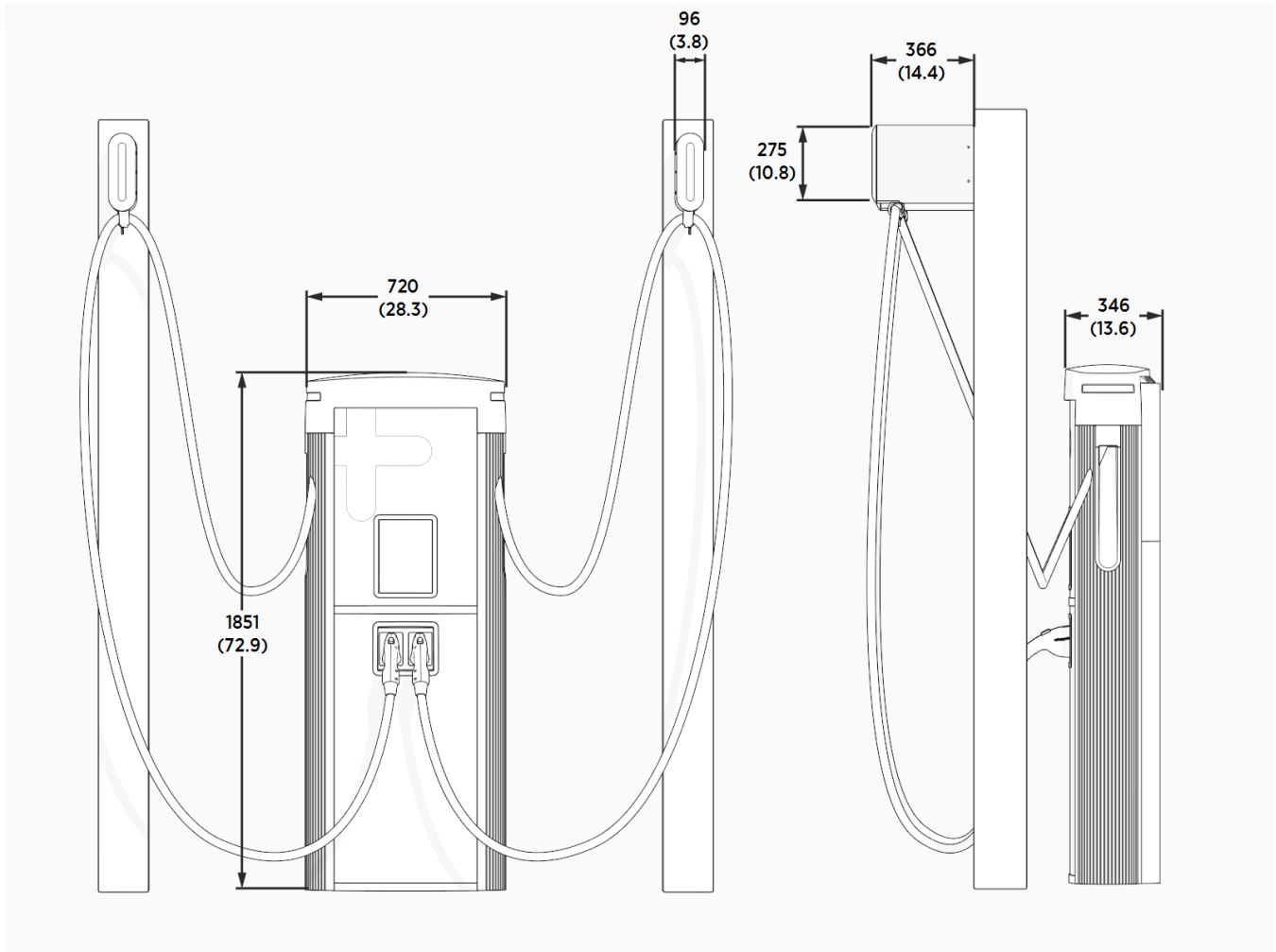

NOTE: The customer must provide the poles at the site for installing pedestal-mount (single or dual cable) Power Link 2000 enclosures with overhead CMK and tether ball extension. These are not provided by ChargePoint.

Overhead-Mount Power Link 2000 With Single or Dual Cable and Overhead CMK

The CMK might not fully retract certain charging cables due to their heavier weight. Adding a tether point and a tether hook kit reduces cable weight on the CMK, allowing the cable to retract fully.



NOTE: Images are not to scale. Measurements appear in metric units (mm) followed by imperial equivalents (inches).

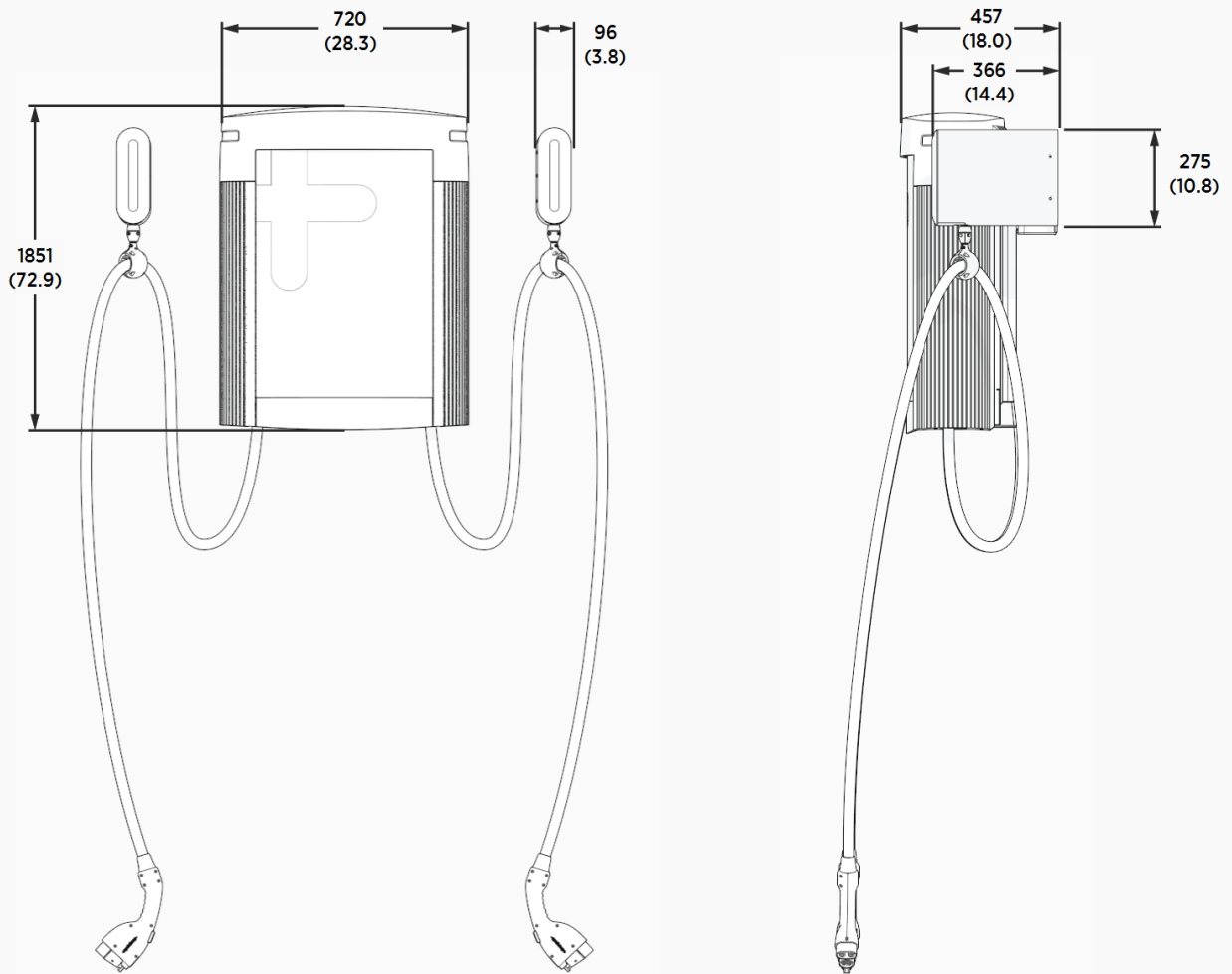

Overhead-Mount Power Link 2000 With Tether Hook

Use tether hooks as additional support for overhead CMKs or to enable the use of third party hoist or cable management solutions.

The tether hook (a) can be attached to either a fixed point or to an alternate cable management mechanism (b) such as a winch.

In the following image, the charge cable is held with a fixed tether hook (a) and a tool balancer (b). Adjust the tether hook or tool balancer location as necessary for site requirements.



NOTE: Images are not to scale. Measurements appear in metric units (mm) followed by imperial equivalents (inches).

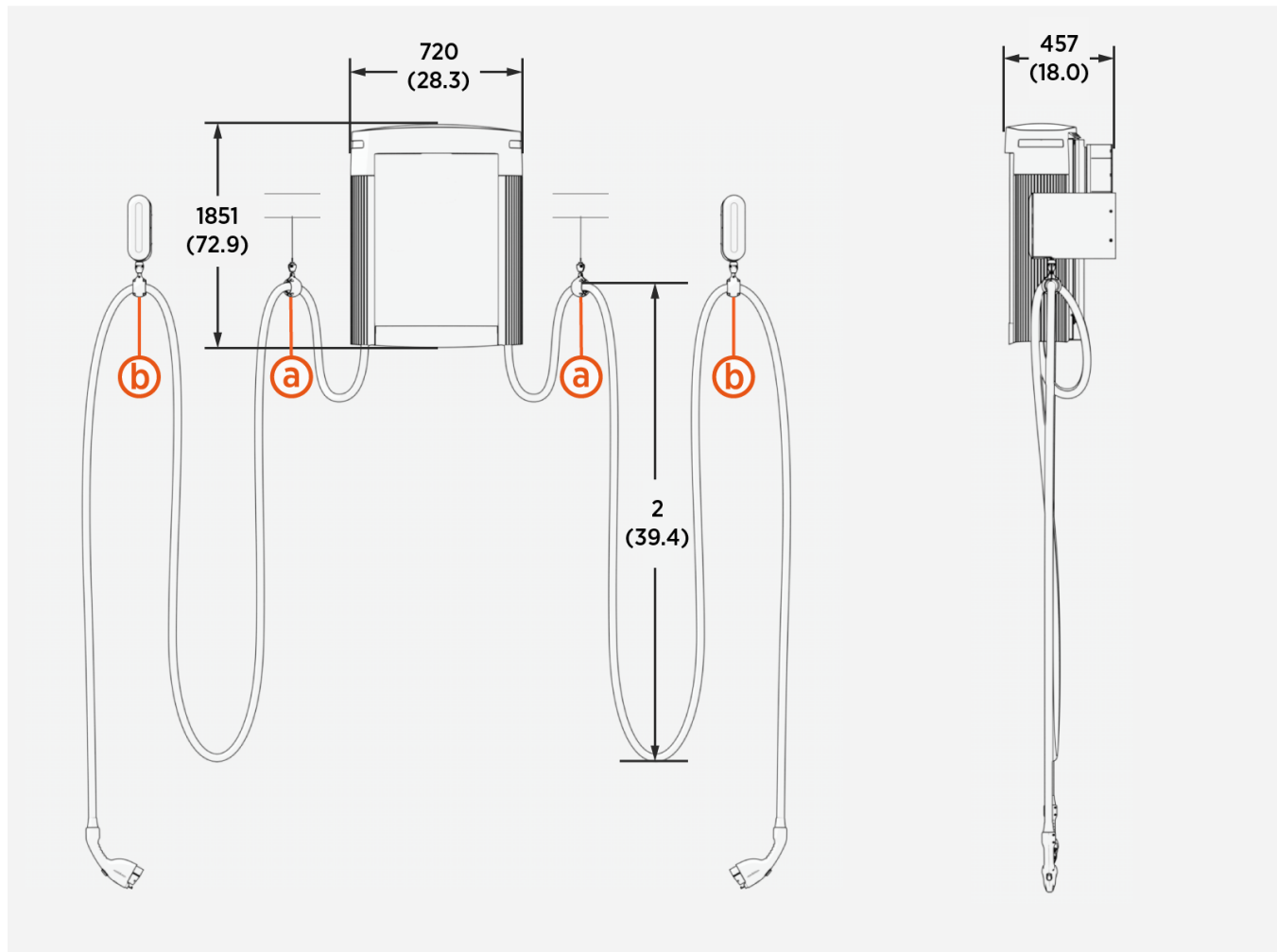

Tether hook dimensions are given in the following image.



NOTE: Images are not to scale. Measurements appear in metric units (mm) followed by imperial equivalents (inches).

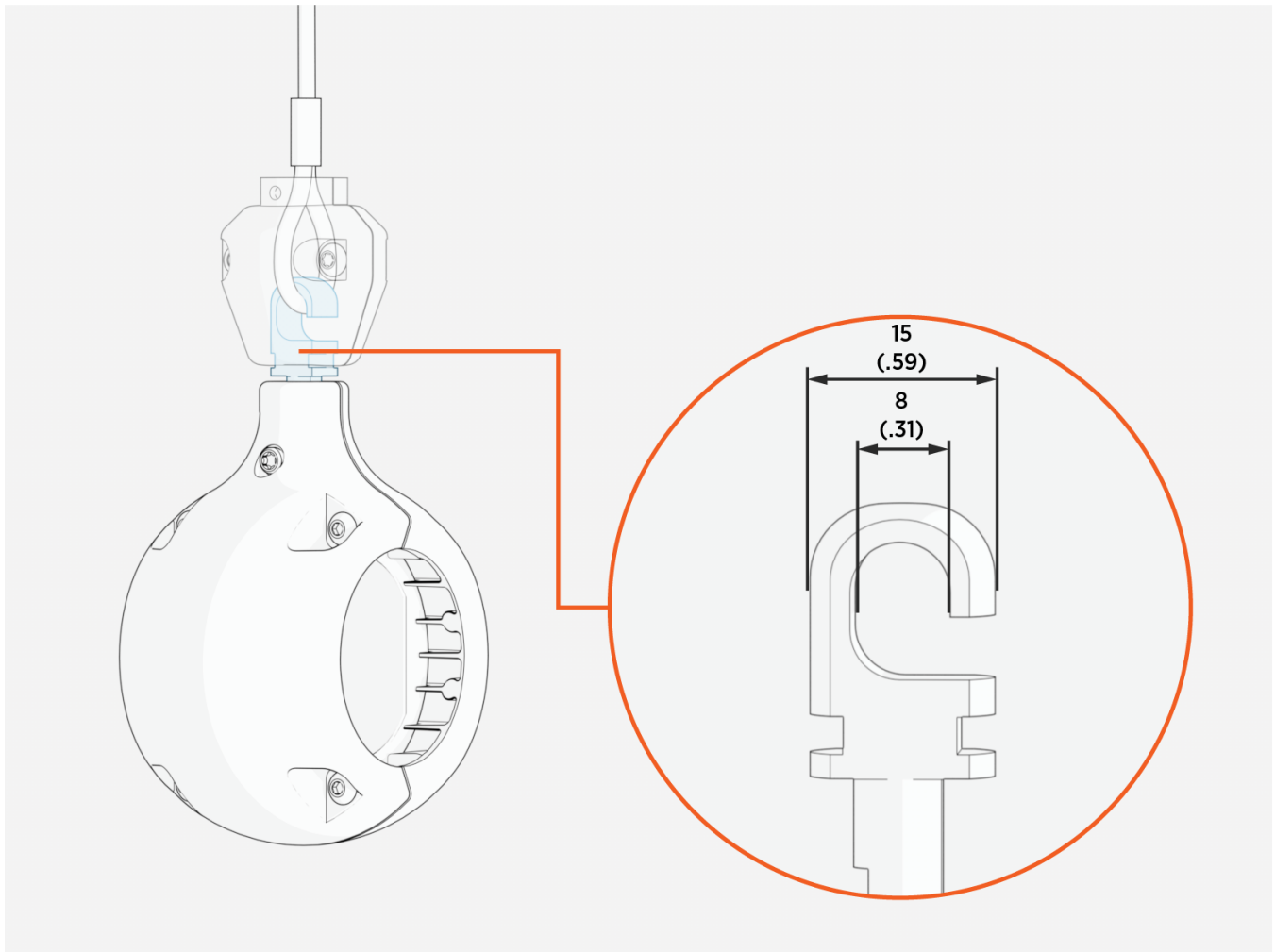

Power Link 2000 Pedestal Mounting Specifications

The pedestal-mount Power Link 2000 must be installed on either a newly poured concrete pad embedded with the Concrete Mounting Template (CMT) or on an existing concrete surface using the Surface Conduit Entry (SCE) kit.

Another option available through a third party is precast concrete blocks. For more details, contact ChargePoint.



IMPORTANT: Stub-up entry of wires laid underground is the most common installation method. Surface entry of wires laid above ground is allowed only at sites where the wires cannot be laid underground such as in a parking garage. Contact ChargePoint for the Surface Conduit Entry (SCE) kit, which includes the hardware needed to install on an existing concrete surface.



WARNING: If not installed correctly, the ChargePoint charging station may pose a crushing hazard, leading to death, personal injury, or property damage. Always use the Concrete Mounting Template specified in this document section, or a ChargePoint-approved surface mounting solution, to install the ChargePoint charging station. Always install in accordance with applicable codes and standards using licensed professionals. Non-approved installation methods are performed at the risk of the contractor and void the Limited One-Year Parts Exchange Warranty.

Concrete Pad Specifications

The pedestal-mount Power Link 2000 must be installed on a concrete pad or engineered foundation. The concrete pad may be either newly poured or an existing concrete surface, provided it meets the requirements below.

Surface requirements

The concrete surface must be smooth and may not exceed a slope of 10 mm per meter (0.12 in per ft).

If an existing surface does not meet this requirement, a localized leveling pad must be poured to achieve the required slope tolerance.



IMPORTANT: Adhering to the slope requirement is critical for cabinet stability, proper alignment, and long-term structural performance.

New concrete pad requirements

A new concrete pad may be:

- Site-specific, designed by a licensed structural engineer, or
- Selected from the standard pad specifications provided in this section.

Conservative stability specifications for the Power Link 2000 are listed in the table below for the following design scenarios:

1. 170 mph wind, high seismic, Class 3 Soil
2. 170 mph wind, high seismic, Class 4 Soil
3. 170 mph wind, high seismic, Class 5 Soil
4. 140 mph wind, lower seismic, Class 3 Soil
5. 140 mph wind, lower seismic, Class 4 Soil
6. 140 mph wind, lower seismic, Class 5 Soil

All scenarios assume:

- Minimum concrete rating of 2500 PSI.
- All-threaded M16 anchor bolts are embedded 229 mm (9 in) into the concrete pad and are made of ASTM F1554 Grade 55 carbon steel and hot dip galvanized (HDG).
- The anchor bolts placement is centered within the designed stability area.

Design Scenarios	Pad Width		Pad Thickness	#N1 @ S1" O.C. Top Rebar	#N2 @ S2" O.C. Bottom Rebar
1	1499 mm (59 in)	1499 mm (59 in)	432 mm (17 in)	#4 @ 305 mm (12 in) O.C.	#4 @ 305 mm (12 in) O.C.
2	1499 mm (59 in)	1499 mm (59 in)	610 mm (24 in)	#5 @ 305 mm (12 in) O.C.	#5 @ 305 mm (12 in) O.C.
3	1499 mm (59 in)	1499 mm (59 in)	610 mm (24 in)	#5 @ 305 mm (12 in) O.C.	#5 @ 305 mm (12 in) O.C.
4	1219 mm (48 in)	1219 mm (48 in)	330 mm (13 in)	#4 @ 305 mm (12 in) O.C.	#4 @ 305 mm (12 in) O.C.
5	1219 mm (48 in)	1219 mm (48 in)	483 mm (19 in)	#5 @ 305 mm (12 in) O.C.	#5 @ 305 mm (12 in) O.C.
6	1219 mm (48 in)	1219 mm (48 in)	483 mm (19 in)	#5 @ 305 mm (12 in) O.C.	#5 @ 305 mm (12 in) O.C.

In extreme environmental conditions, a larger pad may be required. Conversely, sites with less stringent wind, seismic, or soil conditions may allow for a smaller pad, subject to engineering approval.

Existing pad requirements

An existing concrete pad may be used if it meets one of the conservative stability specifications listed above, or if it is evaluated and approved by a structural engineer using the parameters below.

Parameter	Value
Weight	See Weights
Height x width	See Dimensions
Frontal area	Height * width
CG height	1524 mm (60 in)
Anchor bolts size and quantity	M16 (x4)
Anchor bolts embedment	229 mm (9 in)
Anchor bolts placement	See Anchor Bolts Placement

Anchor Bolts Placement

The Power Link 2000 pedestal mounts over four anchor bolts embedded in the concrete pad. The anchor bolt pattern is given below.



NOTE: Images are not to scale. Measurements appear in metric units (mm) followed by imperial equivalents (inches).

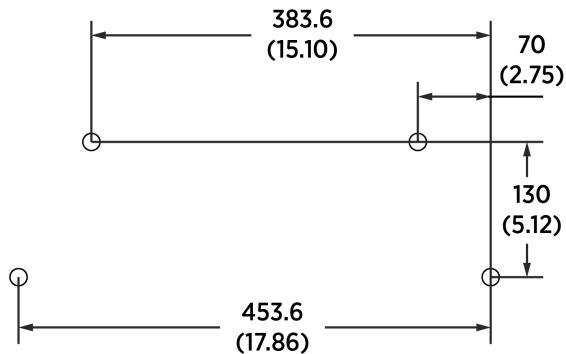

Standard Mount with Concrete Mount Template

The most common mounting method for the pedestal-mount Power Link 2000 is new pad installation using a Concrete Mounting Template (CMT) with conduit stub-up wire entry.

- The Power Link 2000 pedestal mounts onto four M16 anchor bolts exposed 76 mm (3 in) above the concrete pad.
- The CMT is embedded in a newly poured concrete pad to align anchor bolts and underground run stub-up wiring conduits or armored cables.

The Power Link 2000 CMT positions the anchor bolts and conduits stub-ups as shown below.

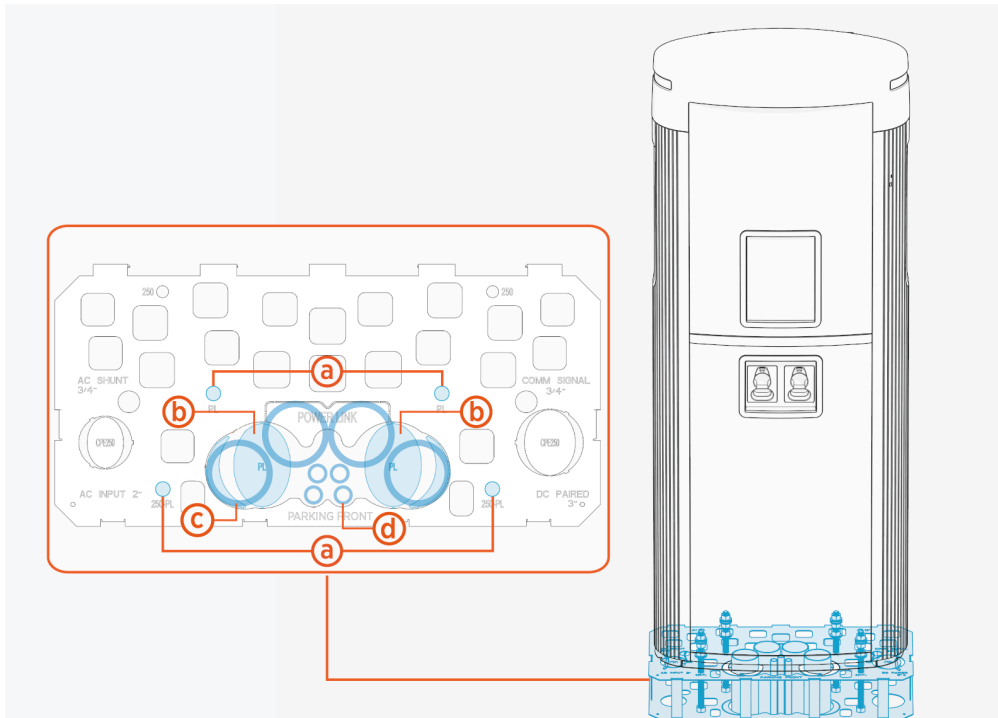

- (a) M16 anchor bolt (x4) locations (see [Anchor Bolts Placement](#)).
- (b) Breakaway tabs for conduits or armored cables.
- (c) Conduits for DC power path input wires (sample conduit configuration shown).
- (d) Conduits for 48 V DC and Ethernet wires (sample conduit configuration shown).

In regions that do not use conduits and/or use armored cables, the cables may be laid per the conduit layout defined by the CMT.



NOTE: The Power Link 2000 CMT is shipped separately and must be assembled onsite before pouring the concrete pad. The CMT must be embedded with its top panel positioned 51 mm (2 in) below the concrete surface. Refer to the *Concrete Mounting Template Guide* for further details.

For standard mount conduit quantity and size requirements, refer to [Conduit Requirements](#).

Surface Mount

The pedestal-mount Power Link 2000 may be installed on an existing concrete surface in accordance with the following guidelines:

- The concrete surface must be inspected and approved by a structural engineer as described in [Concrete Pad Specifications](#).

- The anchor bolts must be installed in the concrete surface as follows:
 - Anchor holes are drilled into the concrete using the anchor bolt pattern given in [Anchor Bolts Placement](#). The holes are drilled to a depth so that 76 mm (3 in) of each anchor bolt remains exposed above the concrete pad.
 - Anchor bolts are epoxied into the holes. Use an epoxy with a minimum bonding strength of 11.7 MPa, compressive strength of 82.7 MPa minimum, and tensile strength of 49.3 MPa minimum. For example, Hilti HIT-RE 500 V3 (normal cure) or Hilti HIT-HY 200-A (fast cure).



NOTE: Different epoxy types have different cure times at various temperatures. Check local temperatures for the site in advance to help choose an appropriate epoxy.

- Use the provided hot-dip galvanized M16 anchor bolts.
- Wires must enter the enclosures using [Surface Wire Entry](#).

Surface Wire Entry

The pedestal-mount Power Link 2000 support wiring that is run above ground in protected wireways for locations where no underground wiring access exists (parking garages, etc.) or where underground junction boxes are not permitted.

If wires or cables are run above ground:

- They must be housed in wireways that conform to local code.
- Ensure the plans for the concrete pad and access area allow full service access to all components. Surface wires entry might require larger clearance areas than embedded installations. A minimum of 610 mm (2 ft) clearance at rear side is required.
- Use flexible wires and conduits, or armored cables.
- Use LB conduit bodies to route wires into Power Link 2000 from rear left or rear right, and they must fit within the rear clearance of 610 mm or 2 ft.
- Use suitable conduit fittings to secure and seal the conduits and/or conduit bodies.
- Prepare the concrete surface where the components will be anchored so that the concrete surface is solid, smooth, and level with no old hardware or stub-ups extending above ground.

Surface wires must enter the pedestal-mount Power Link 2000 using a Surface Conduit Entry (SCE) Kit. The SCE Kit offers the following benefits:

- Support of the weight of conduits or armored cables without compromising cover panel integrity
- Ensure all terminations meet ingress requirements where they meet the component
- Ensure no obstructions to ventilation, which is required during operation

The SCE Kit provides a sturdy pedestal cover panel onto which surface conduits or armored cables may be fastened at the rear side of the Power Link 2000.

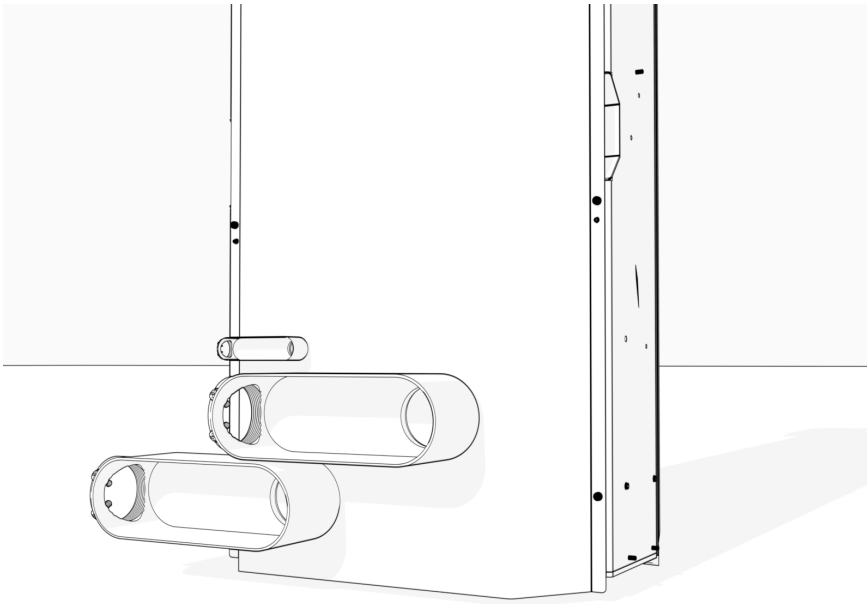

For further information on the SCE Kit, refer to the *Power Link 2000 Installation Guide*. For conduit quantity and size requirements when utilizing the SCE Kit, refer to [Conduit Requirements](#).



NOTE: The SCE kit is used for surface wire entry for only the pedestal-mount Power Link 2000. It can not be used with a overhead-mount Power Link 2000.

Cable Management Kit Mount Specifications

Standard and Tall CMK

For pedestal-mount Power Link 2000, the standard and tall CMKs mount to the back of Power Link 2000. Refer to [Dimensions](#) for overall mounting dimensions of Power Link 2000 with standard or tall CMK. The standard CMK can be adjusted to a lower height for parking garages. Refer to the *Express Distro Power Link 2000 Installation Guide* for details.

Overhead CMK

If you want to use an overhead CMK with a pedestal-mount Power Link 2000, you must install a pole to mount the overhead CMK next to the Power Link 2000 charging cables.

To mount the overhead CMK for a pedestal-mount Power Link 2000:

- You must design and/or purchase the pole. ChargePoint does not sell and/or supply the pole.
- The pole must have a structural capacity of 1780 N (400 lbf), and it must be designed or verified by a structural engineer per local codes. In the event of a vehicle driveway incident, this structural strength is required to withstand the pull-out force of the vehicle.

- Unless the pole needs to be at a certain location for a specific vehicle inlet, the overhead CMK when mounted onto the pole must have an optimum height of 3 m (10 ft) for maximum cable reach, come at the center of the parking space, and be as far forward as possible aligned with the front of the bollards (see [Bollards](#) for the bollards placement and [Dimensions](#) for the overhead CMK's depth).



NOTE: Images are not to scale. Measurements appear in metric units (m) followed by imperial equivalents (ft).

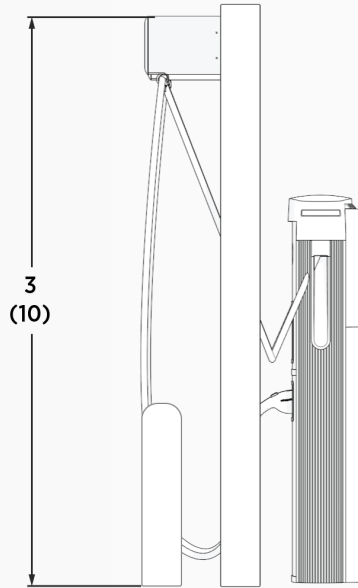

- The overhead CMK must be mounted using its bracket (supplied by ChargePoint) that attaches to its back. The bracket has four holes sized for M8 bolts to mount the overhead CMK onto the pole.



NOTE: The installer must provide the M8 bolts. These are not provided by ChargePoint.



NOTE: Images are not to scale. Measurements appear in metric units (mm) followed by imperial equivalents (inches).

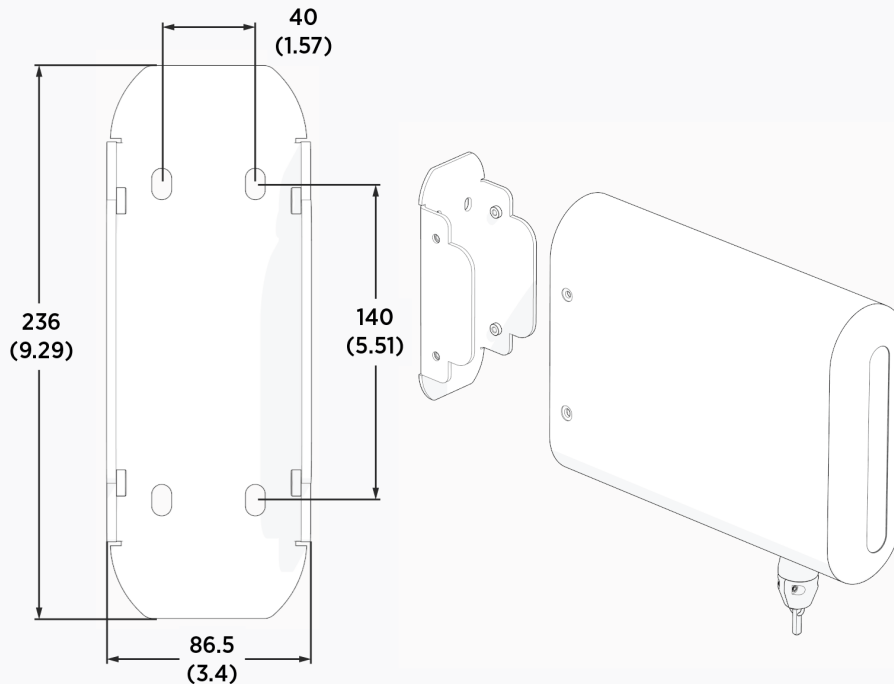

Power Link 2000 Overhead Mounting Specifications

The overhead-mount Power Link 2000 mounts onto a wall or an overhead structure (such as a gantry) using a bracket that attaches to its back. The bracket has six mounting holes sized for M8 bolts.



NOTE: Images are not to scale. Measurements appear in metric units (mm) followed by imperial equivalents (inches).

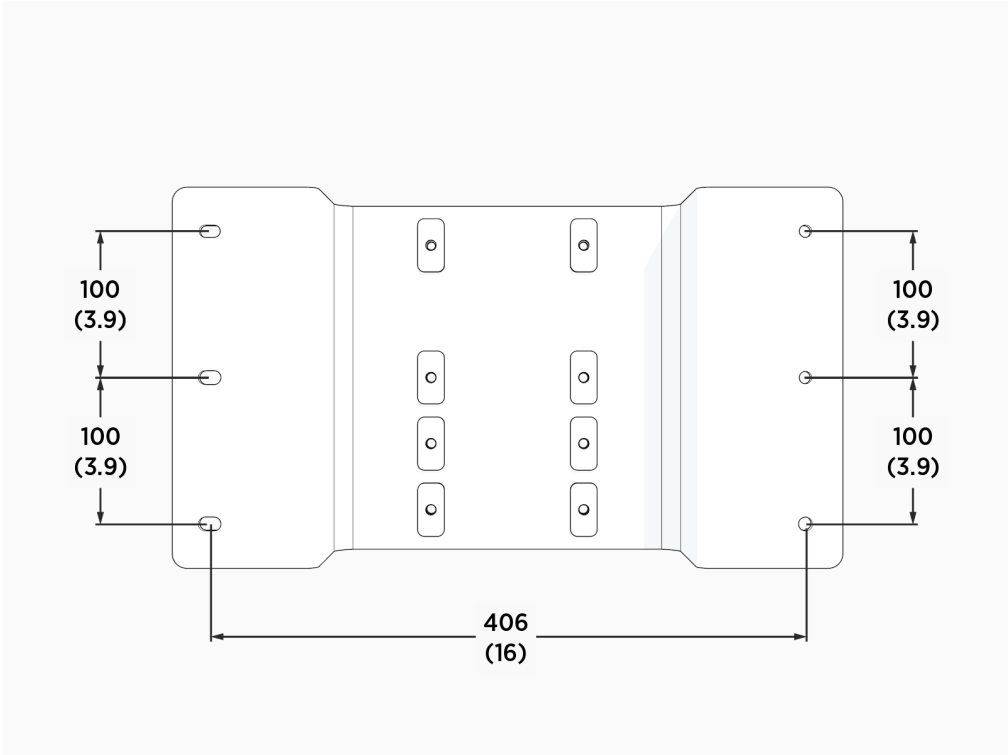
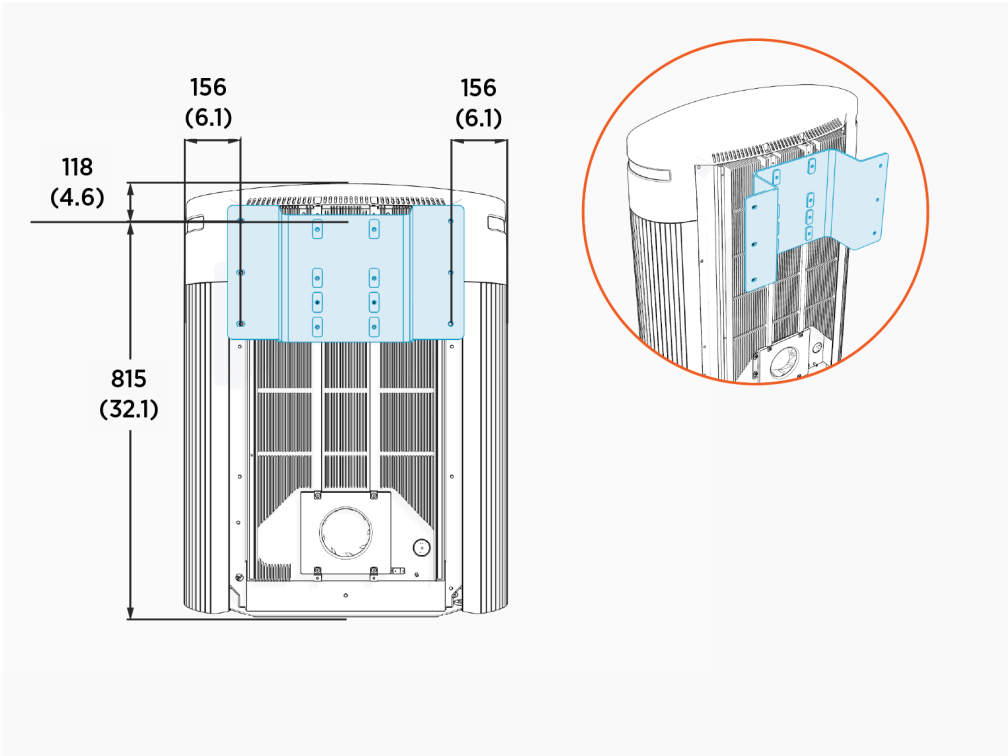

For overhead-mount stations:

- The Power Link 2000 must be mounted upright. Do not mount it in any other orientation.
- The wall must be smooth and plumb.
- The wall or overhead structure must have a structural capacity of 1780 N (400 lbf) in addition to the Power Link 2000 weight. The structure must also be designed or verified by a structural engineer per local codes. In the event of a vehicle drive away incident, this structural strength is required to withstand the pull-out force of the vehicle.

Wires and cables enter overhead-mount Power Link 2000 through its bottom gland plate by conduit or as armored cable. The DC power path input conduits should attach to the gland plate at locations that align the wires to their intended power path landings. See [Wire Terminal and Bus Bar Locations](#)

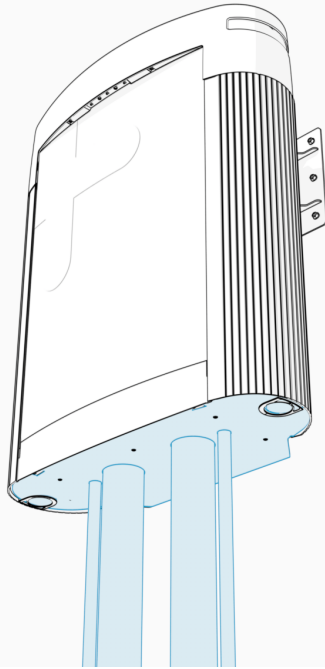

For surface run wiring to the overhead-mount Power Link 2000:

- All wires must be housed in wireways that conform to local code.
- Use flexible wires.
- Use suitable conduit fittings to secure and seal the conduits to the enclosure.

For overhead-mount conduit quantity and size requirements, refer to [Conduit Requirements](#).

Mounting height specifications and guidelines are given below:



IMPORTANT: The height for overhead mount must be calculated based on site specific requirements. For assistance, [contact ChargePoint](#).

- For maximum cable reach :
 - Mount the Power Link 2000 at a height of 6096 mm (240 in) above the finished floor.



NOTE: The mounting height can be adjusted based on site needs.

- Mount the overhead CMK bracket in-line and 203 mm (8 in) away from the Power Link 2000 bracket.



NOTE: Images are not to scale. Measurements appear in metric units (mm) followed by imperial equivalents (inches).

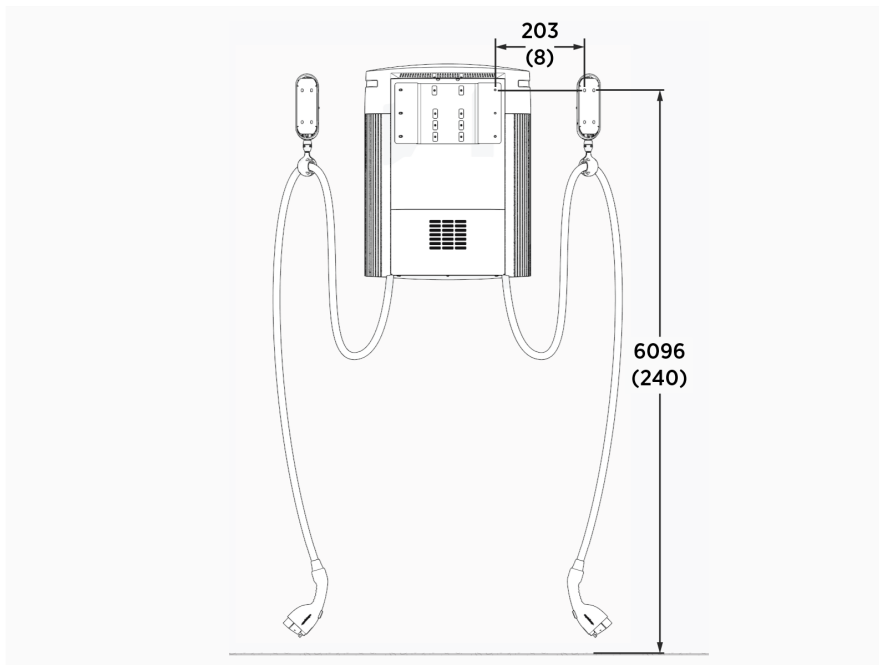

- The overhead CMK bracket must be mounted a minimum of 203 mm (8 in) away from the outer sides of the Power Link 2000 mounting bracket.

- The overhead CMK cable measures 3 m (118 in) when fully extended.

 **NOTE:** Images are not to scale. Measurements appear in metric units (m) followed by imperial equivalents (inches).

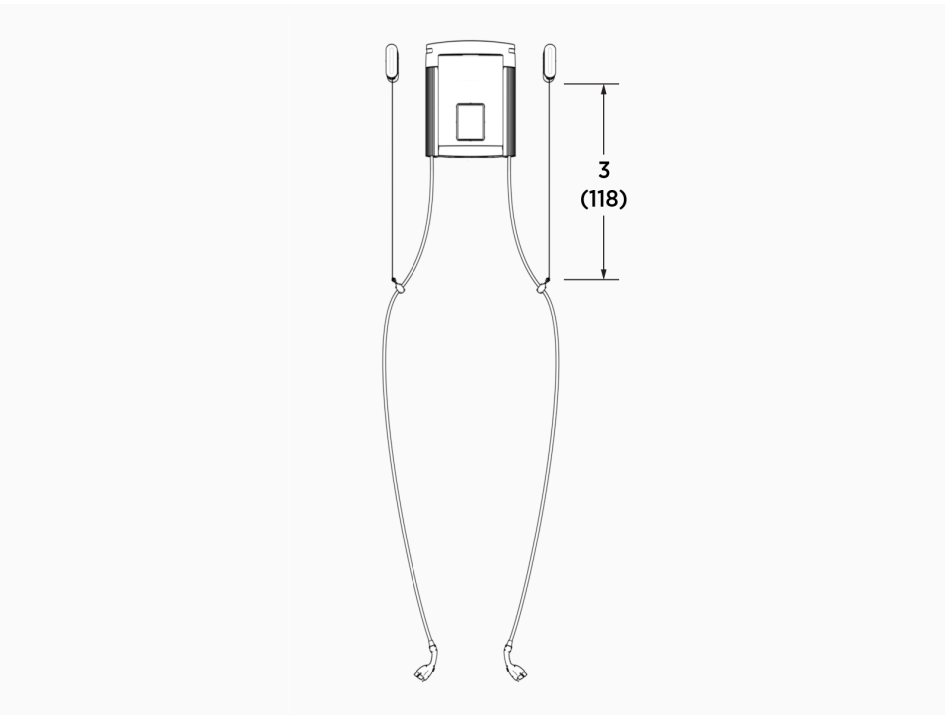

Drainage

Ensure any site slopes, walls, or fencing do not trap water around the installation site.

Clearances

The Power Link 2000 requires minimum site and service clearances listed below.

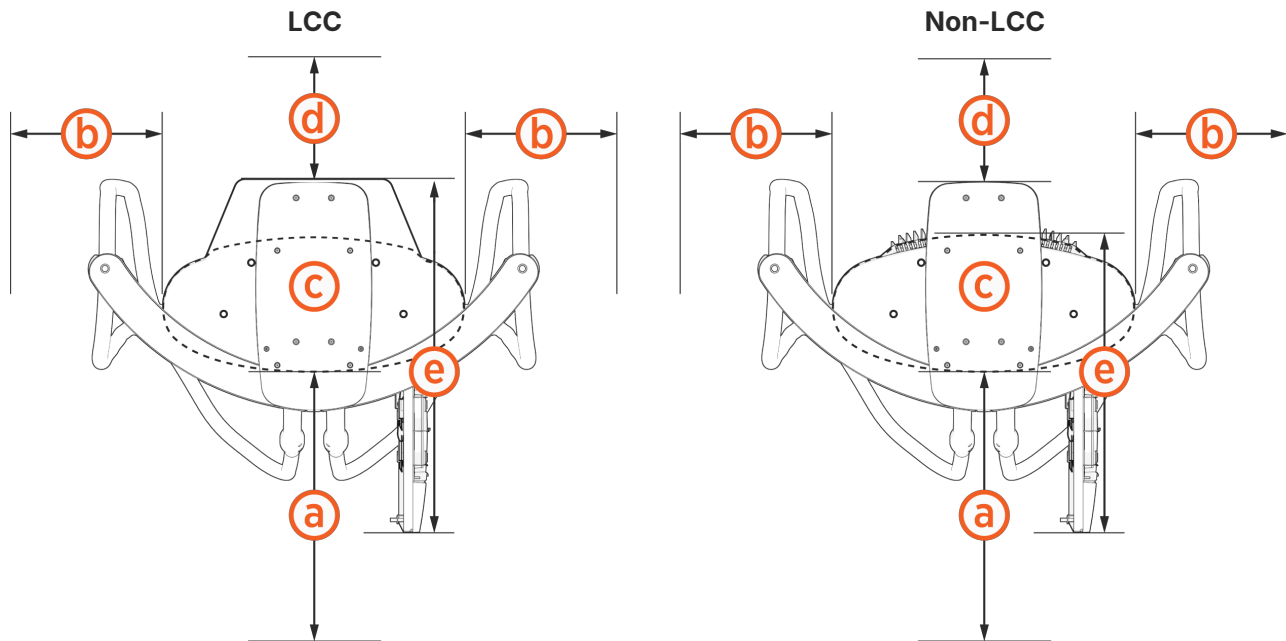

Power Link 2000		Clearance
(a) Front	Minimum open space	610 mm (2 ft)
(b) Side		305 mm (12 in) at grade, minimum NOTE: 610 mm (24 in) recommended for user service and this 610 mm (24 in) can be shared between Power Link 2000s
(c) Top	Pedestal or wall-mount	26 mm (1 in) from top of CMK or 305 mm (12 in) from top of Power Link 2000, whichever is higher.
	Overhead-mount	305 mm (12 in) from top of Power Link 2000
(d) Rear	Pedestal-mount	203 mm (8 in) for non-LCC or 305 mm (12 in) for LCC. This provides service clearance for CMK and LCC. NOTE: At least 610 mm (2 ft) of clearance is required for surface conduit entry. In the case of back-to-back Power Link 2000s, each with surface conduit entry, the clearance can be shared.
(e) Door swing plus station width		730 mm (28.75 in)

Wheel Stops and Bollards

Bollards and wheel stops are not explicitly required by ChargePoint. However, ChargePoint recommends these best practices and considerations when designing the site:

- Permanent bollards or wheel stops must not encroach upon the clearances listed in the clearance diagrams in this section. Removable bollards are allowed if service personnel have the ability to move them as needed.
- Where permitted by code, wheel stops are preferred over bollards for head-in or back-in spaces.

Wheel Stops

- When using wheel stops, consider the average vehicle overhang distance for the largest type of vehicle (passenger, bus, etc.), as well as leaving space for the driver to walk up and access the station.
- Position wheel stops to actively block at least one wheel, without presenting a trip hazard to pedestrians walking between vehicles.

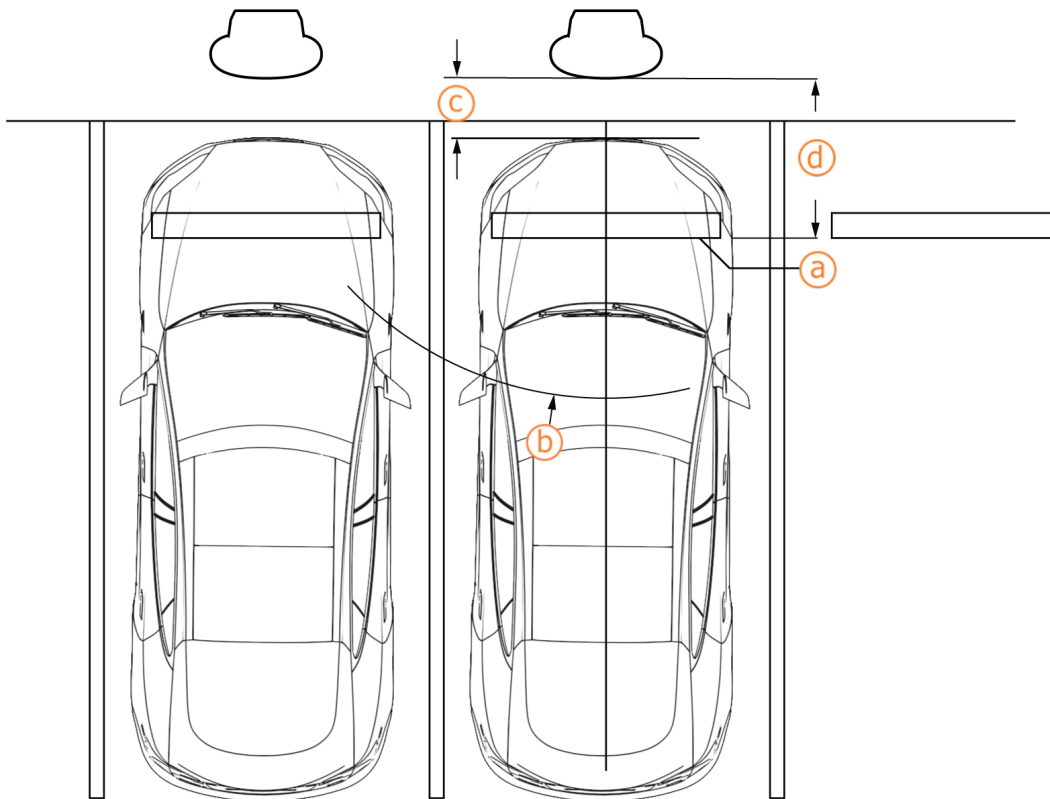

- (a)** Wheel stop, positioned to actively block at least one wheel
- (b)** Cable reach radius: 3.76 m (148 in)
- (c)** Recommended distance for walk-up access: 609 mm (24 in)
- (d)** Recommended distance between wheel stop and station: 1371 mm (54 in) for passenger vehicles

Bollards

- When bollards are required by code, needed for snowy areas, or needed for curbside spaces, ensure bollard placement does not interfere with removing and replacing charge cables in the station's holsters.
- Try to minimize bollard interference with the movement of charge cables between the station and the vehicle. Bollard height is recommended to be no higher than 914 mm (36 in) where needed.
- Follow the measurements listed for bollards placement:
 - (a) Anchor bolt to bollard inside edge: 254 mm (10 in)
 - (b) Anchor bolt to bollard front edge: 424 mm (16.7 in)
 - (c) Power Link 2000 side to bollard inside edge: 122 mm (4.8 in)
 - (d) Power Link 2000 front to bollard front edge: 305 mm (12 in)

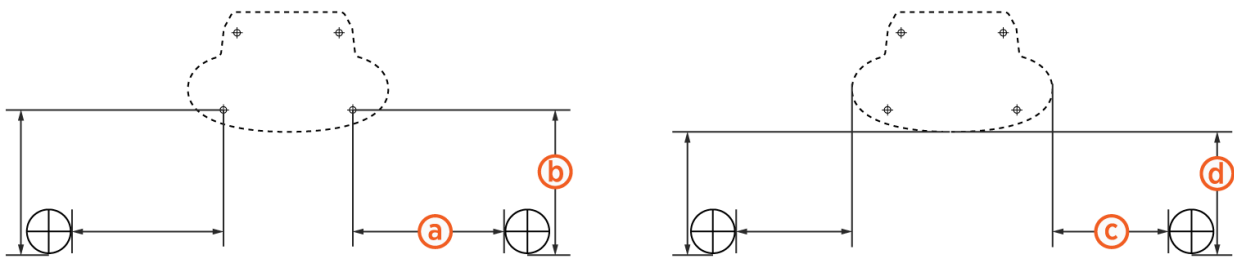

Ventilation

Ensure that any installation, especially an indoor installation, has adequate airflow to dissipate heat at maximum operation. The station location must allow fresh ambient airflow and must be free of any objects that might restrict airflow to the station. A station experiencing temperatures in excess of the maximum allowed operating temperature may deliver reduced maximum performance.



NOTE: Power Link 2000s without liquid cooled cables require 500 W (1,700 BTU/hr) of heat rejection. Power Link 2000s with liquid cooled cables require 5.3 kW (18,000 BTU/hr).

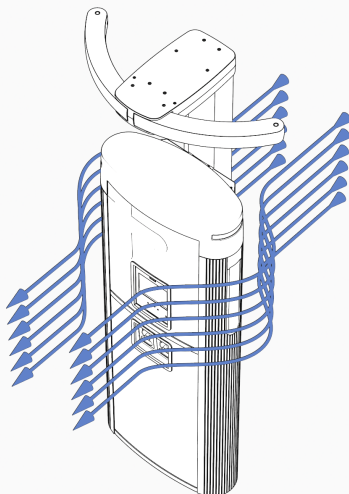

Accessibility

Comply with regional accessibility laws, regulations, and ordinances. The Power Link 2000 charging station must not block ramps or pathways and the height of the interactive display cannot exceed the maximum height as dictated by local laws.

Do not install Power Link 2000 on a raised concrete pad for parking spaces reserved for people with limited mobility. Power Link 2000 meets ADA height requirements when measured from a finished floor or ground plane (i.e., Power Link 2000's all operable parts, such as cable connectors and display, are no higher than 1220 mm or 48 in and no lower than 381 mm or 15 in from a finished floor or ground plane).

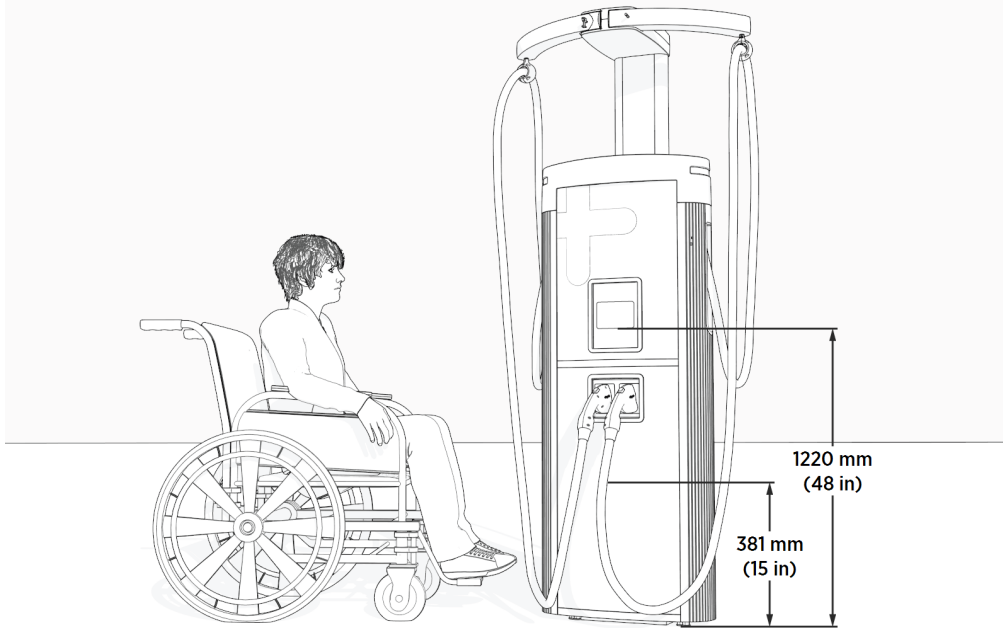

Signage

Refer to local and regional code to design the following elements for the site:

- Any required re-stripping of parking spaces
- EV or Accessible EV signs
- EV or Accessible EV paint markings on and around the parking spaces

Electrical Design 4

This section provides electrical site design specifications for Power Link 2000.

Conduit and wire size are determined based on current. Service wiring in conduit or armored cable must be run as required to comply with local electrical codes. Consult national and local codes or a project engineer to determine the grade, quality, and size of the conduit or cable.



NOTE: All wiring and conduit is supplied by the contractor unless otherwise indicated.



IMPORTANT: If a site requires surface conduit entry installation, contact ChargePoint before beginning work to obtain an approved installation method. If the station is being fed power by more than two Power Blocks, surface conduit entry installation is not permitted.

The following illustration shows a sample electrical circuit, including an optional component, for an Express cluster consisting of one Power Block 2000 feeding one Power Link 2000.

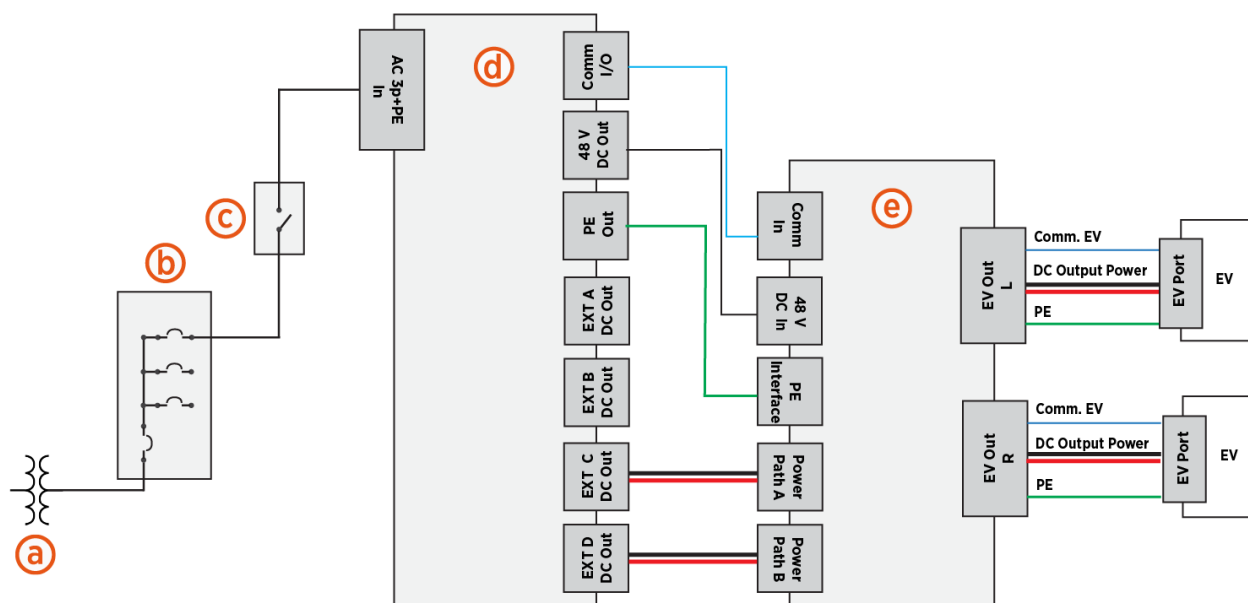

- (a) Transformer
- (b) Electrical panel with circuit breakers
- (c) AC disconnect switch (optional)
- (d) Power Block 2000 (sample power cabinet)
- (e) Power Link 2000

Grounding Requirements

All stations within the Express platform have metallic accessible enclosures and rely on protective earth or ground connection for protection against electrical shock.

A Power Link 2000 must be connected to a grounded, metal, permanent wiring system. The equipment-grounding conductor shall be routed with the circuit conductors and terminated at the equipment-grounding terminal inside the Power Link 2000.

The equipment-grounding conductor must remain continuous and bonded in sequence from the upstream power source to the Power Link 2000. This includes installations where the upstream source is a power cabinet such as an Express Solo or Power Block 2000. Bonding must ensure that all stations in the circuit share a common protective earth path.

All grounding and bonding practices must comply with applicable local electrical codes and with the grounding requirements specified in the site design guide for the upstream power cabinet. For detailed power cabinet grounding requirements, refer to the site design guide for the upstream power cabinet.

Power Link 2000 Soft Shutdown

The soft shutdown function is an optional feature that can be installed as a way to stop a charge session on that Power Link 2000. It is not meant to safely service the Power Link 2000 or take the place of a [DC maintenance switch](#).

To use this feature, the installer must select and mount a physical soft shutdown switch (one per Power Link 2000) with the following specifications:

- THHN insulation building wire rated to 600 V
- Normally Open (NO) configuration
- Switch current of 2 ma
- Switch voltage of 48 V
- Gold contacts suggested

When creating the site drawings, consider where any soft shutdown switches should be positioned. If applicable, consider disability and accessibility regulations for your region when choosing switch locations.



NOTE: Soft shutdown switch requires a dedicated conduit. For more information, refer to [Conduit Requirements](#).

When the switch is closed, the Power Link 2000 software ends the current charging session with a normal stop, then opens DC contactors in the Power Link 2000. The station stays in this state regardless of station power, not allowing operation. Only a service technician can place the Power Link 2000 back into service after the switch is reset to Open.



WARNING: The DC power path input wires could still be energized by the power cabinet with the switch closed.

DC Maintenance Switch

If an external DC disconnect switch is used, then the switch must be configured with Normally Closed (NC) contact feedback wired into each Power Link 2000. The DC Maintenance Switch is an optional part available for the pedestal-mount Power Link 2000. It is ordered and shipped separately and is field installed.

Sequential Charging Kit

Dual output Power Link 2000s may be configured for sequential charging by field installing a Sequential Charging Kit. This kit allows Power Link 2000 to take a single power input and feed the power to either output in a sequential manner. The Sequential Charging Kit is ordered separately and is field installed.

Ethernet to USB Kit

Ethernet to USB is an optional kit that allows an Express cluster (interconnected power cabinets and Power Link 2000s) to have a hardwired Ethernet connection with an external network server.

The Ethernet to USB kit is installed within a single Power Link 2000, providing network connection for every node in the Express cluster. The installation requires a conduit for the Ethernet cable, which must be run from the customer server or network equipment directly to the Power Link 2000.

This kit must be ordered separately and installed in the field.

Wiring and Conduit Requirements

Refer to the *Express Power Link 2000 Datasheet* at [ChargePoint Product Reference Documentation](#) for full product specifications.

Ensure that the installation location is equipped with service wiring that support the station's power requirements.

Conduit and wire size are determined based on current. Service wiring in conduit or armored cable must be run as required to comply with local electrical codes. Consult national and local codes or a project engineer to determine the grade, quality, and size of the conduit or cable.



NOTE: All wiring and conduit is supplied by the contractor unless otherwise indicated.

Wire Run Lengths

- The maximum total wire run length from a power cabinet to the Power Link 2000 must not exceed 200 m (656 ft). Refer to the cluster configuration provided by ChargePoint for interconnect details.
- For 48 V DC wire and Ethernet runs between nodes (i.e., power cabinet and Power Link 2000):
 - For non-LCC Power Link 2000:
 - Without daisy chaining, the 48 V and Ethernet wire run length between the power cabinet and Power Link 2000 can be up to 200 m (656 ft).
 - With daisy chaining, the maximum total wire run length from the power cabinet to the furthest Power Link 2000 is 160 m (525 ft). Contact ChargePoint for options if greater lengths are needed.
 - For LCC Power Link 2000:
 - The 48 V and Ethernet wire run length between power cabinet and Power Link 2000 can be up to 100 m (328 ft). Contact ChargePoint for options if greater lengths are needed.
- The maximum wire run length between a Power Link 2000 and an external network connection is 200 m (656 ft). Refer to the cluster configuration provided by ChargePoint for interconnect details.

Ethernet Cable Type and Configuration

- For Ethernet communications between any two nodes (for example, between a Power Link 2000 and an upstream power cabinet, or between a Power Link 2000 and an external network connection):
 - Distances up to 100 m (328 ft) must use outdoor-rated Cat6 Shielded Twisted Pair (STP) cable. Lesser grades of cable do not provide the required noise immunity.
 - Distances between 100 m (328 ft) and 200 m (656 ft) must use Paige OSP Shielded GameChanger cable. See paigedatacom.com/gamechanger.
- An Ethernet cable connecting a power cabinet and a Power Link 2000 must have the shield terminated at the power cabinet end.
- An Ethernet cable connecting two daisy-chained Power Link 2000s must have the shield terminated at the end nearer to the power cabinet.

Conduit Requirements

To ensure proper fit, environmental protection, and compliance with enclosure tolerances, the following requirements apply when conduits are used:

- The conduits must be sealed to maintain a Pollution Degree 2 environment.
- The conduits must not have bell ends. Conduits with bell ends may interfere with tolerances inside the Power Link 2000.
- If using conduit stub-ups in a pedestal-mount Power Link 2000, conduits must stub up between 13 and 25 mm (0.5 and 1 inch) above the mounting surface.

Conduit quantity and size - Pedestal-mount with stub-up wire entry



IMPORTANT: The following table provides the maximum size and quantity of conduits that can be installed for a pedestal-mount Power Link 2000 configured for wire entry via conduit stub-ups. The actual conduit size and quantity must be chosen based on site specific wiring requirements.

Conduits For	Conduit Quantity x Trade Size
DC power path input wires	2 x 4 inch max. or 4 x 3 inch max. or 6 x 2 inch max.
48 DC wires and Ethernet cable	2 x 1 inch (*)
Optional features (Ethernet to USB or soft shutdown switch)	2 x 3/4 inch max.



NOTE: (*) 48 V DC and Ethernet wires travel in the same conduit. 1 inch conduit size is required. The quantity of conduit will depend on configuration.

Conduit quantity and size - Pedestal-mount with surface wire entry



IMPORTANT: The following table provides the maximum size and quantity of conduits that can be installed for a pedestal-mount Power Link 2000 configured for wire entry via the Surface Conduit Entry (SCE) kit. The actual conduit size and quantity must be chosen based on site specific wiring requirements.

Conduits For	Conduit Quantity x Trade Size
DC power path input wires	2 x 3 inch max.
48 DC wires and Ethernet cable	2 x 1 inch (*)
Optional features (Ethernet to USB or soft shutdown switch)	2 x 3/4 inch max.



NOTE: (*) 48 V DC and Ethernet wires travel in the same conduit. 1 inch conduit size is required. The quantity of conduit will depend on configuration.

Conduit quantity and size - Overhead-mount with surface wire entry



IMPORTANT: The following table provides the maximum size and quantity of conduits that can be installed for an overhead-mount Power Link 2000. The actual conduit size and quantity must be chosen based on site specific wiring requirements.

Conduits For	Conduit Quantity x Trade Size
DC power path input wires	2 x 4 inch max. or 4 x 3 inch max.
48 DC wires and Ethernet cable	2 x 1 inch (*)
Optional features (Ethernet to USB or soft shutdown switch)	2 x 3/4 inch max.



NOTE: (*) 48 V DC and Ethernet wires travel in the same conduit. 1 inch conduit size is required. The quantity of conduit will depend on configuration.

Wire Terminal and Bus Bar Locations

This section illustrates the wire terminal and bus bar locations within the Power Link 2000.

Pedestal-Mount Power Link 2000



NOTE: Depending on configuration, the pedestal-mount Power Link 2000 has one or two DC power paths, named A and B. Each power path has two wire landings, an upper landing and a lower landing. Power Link 2000s with a single charging cable are configured with Power Path B landings only.

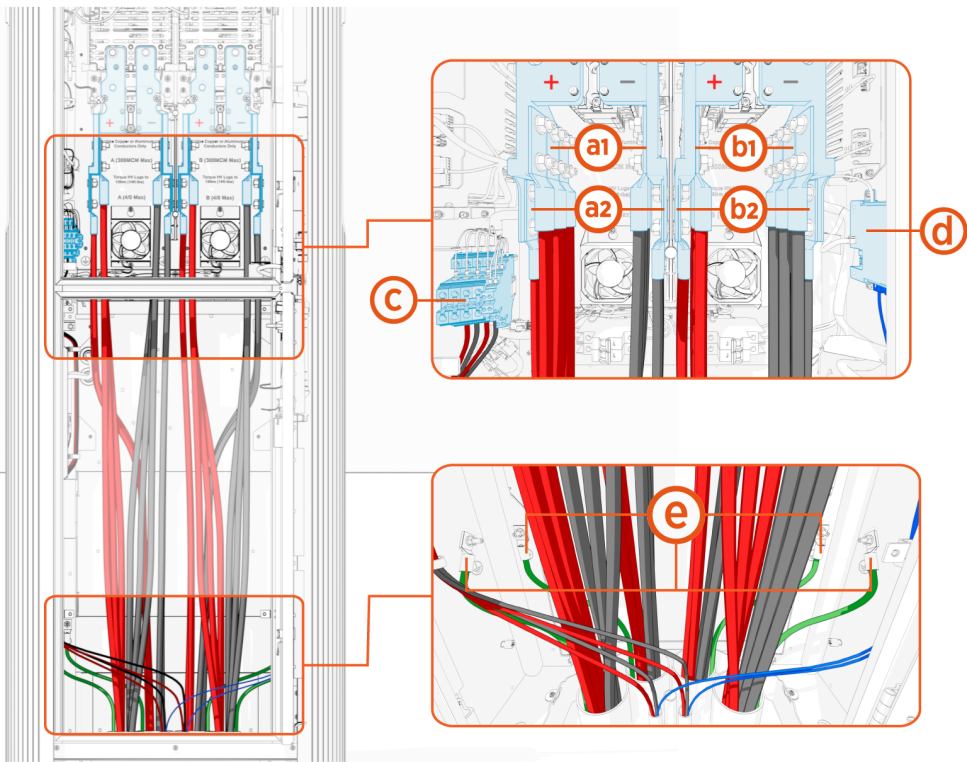

- (a1)** DC Power Path A, upper landing
- (a2)** DC Power Path A, lower landing
- (b1)** DC Power Path B, upper landing
- (b2)** DC Power Path B, lower landing
- (c)** 48 V DC and soft shutdown
- (d)** Ethernet
- (e)** Ground

Consider the height of the DC power path bus bars above the concrete pad when determining the wire length required.

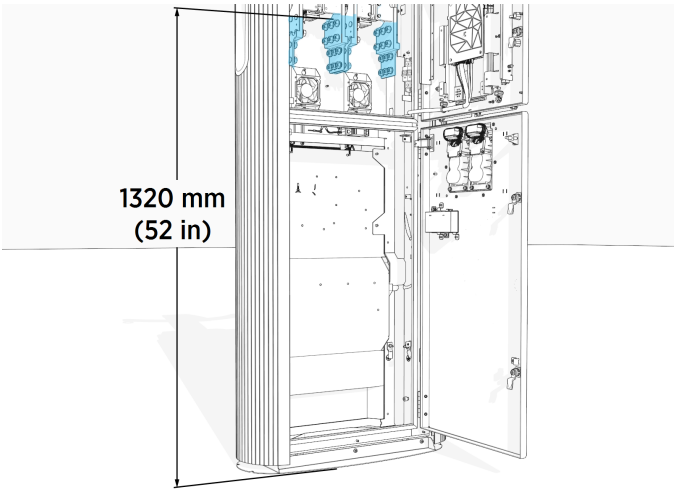

Overhead-Mount Power Link 2000



NOTE: Depending on configuration, overhead-mount Power Link 2000s have one or two DC power paths, named A and B. Each Power Path has two wire landings, an upper landing and a lower landing. Single-output Power Link 2000s are configured with only a right-side charging cable and Power Path B landings only.

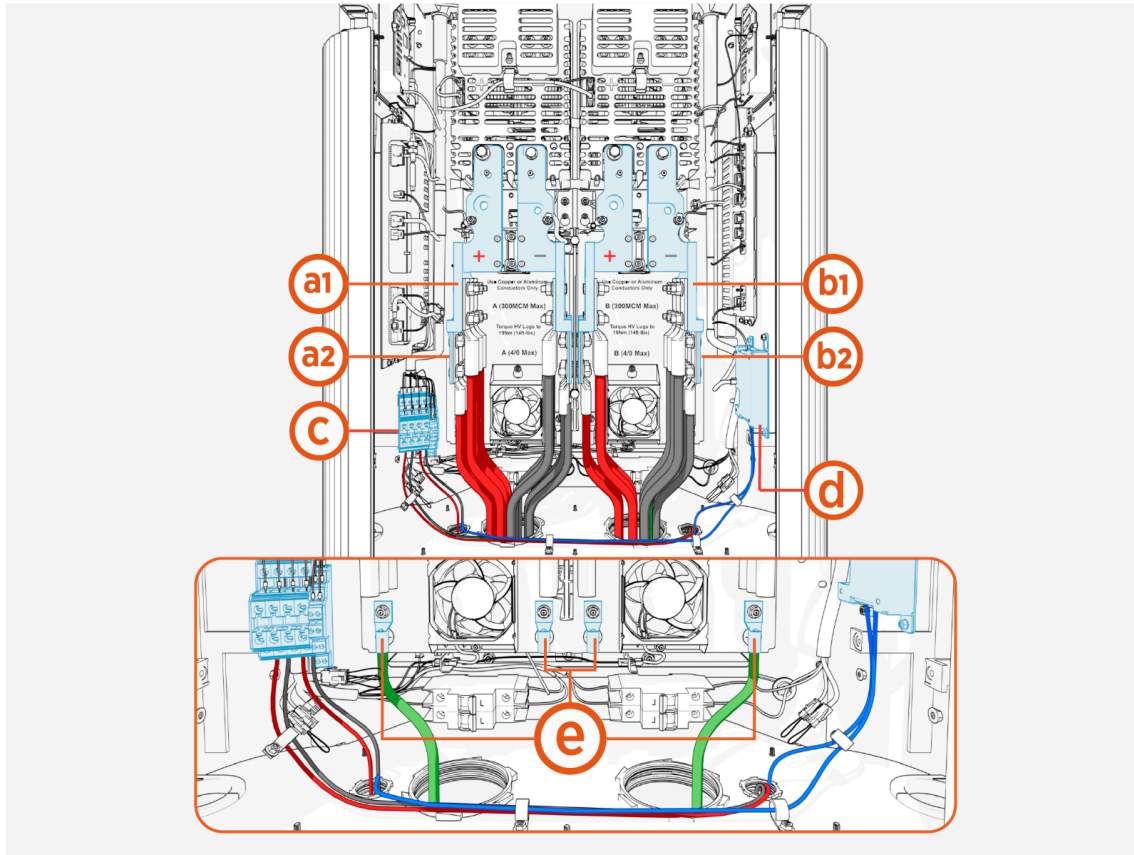

- (a1)** DC Power Path A, upper landing
- (a2)** DC Power Path A, lower landing
- (b1)** DC Power Path B, upper landing
- (b2)** DC Power Path B, lower landing
- (c)** 48 V DC and soft shutdown
- (d)** Ethernet
- (e)** Ground

Wire Specifications

IMPORTANT:

- For DC power path high-current wiring:
 - Use copper or aluminum wires rated for 90 °C (194 °F).
 - Wires can be XHHW/XHHW-2 based on site condition (dry or wet) and must be rated for 1000 V.
- For 48 V DC and soft shutdown wiring, use copper wiring only. Wires can be XHHW/XHHW-2 based on site condition (dry or wet). Wires must be rated for 1000 V and 75 °C (167 °F).
- Use copper lugs for copper wires and aluminum lugs for aluminum wires. The lugs must be nickel, tin, or silver plated compression (not mechanical) lugs. Nickel-plated lugs installed with dielectric grease is recommended.
- When using aluminum lugs, ChargePoint recommends using an appropriate antioxidant compound on aluminum conductors when terminating into tin-, nickel-, or silver-plated lugs, where required by code or specified by the lug manufacturer.



IMPORTANT: All DC power path wires must undergo insulation testing as outlined in the *Express Plus High Voltage Wire Insulation Resistance Test Field Guide*.



IMPORTANT: Following are wire specifications for the Power Link 2000, including the maximum quantity and size that the wire terminals can accommodate. All sizing assumes a maximum ambient temperature of 50 °C (122 °F). Where the maximum wire size is listed, the actual wire quantity and size must be chosen based on site-specific wiring requirements and in accordance with the maximum allowed conduit filling rate per local code.

Wire	Quantity	Size	Termination
DC Power Paths A and B (max. 500 A per landing)	Max. 12 wires per Power Path (three wires per pole on each landing)	Upper landings: 300 MCM(*)	Lug: Long barrel and tongue with two holes spaced 44.5 mm (1.75 in) apart and sized for M12 (0.5 inch) studs. Max. lug tongue width: 31 mm (1.25 in) for upper landings, 25.9 mm (1 in) for lower landings. Aluminum lug max. tongue thickness: 10 mm (0.4 in) for upper landings, 5 mm (0.2 in) for lower landing.
		Lower landings: 4/0 AWG	
DC Ground	Max. 6 wires (one per Power Block)	Refer to the local code for size; max. 1/0 AWG	Lug: Short barrel and tongue with single hole, sized for M6 stud.
48 V DC	Max. 8 wires (four wire pairs; each pair has one wire per pole)	6 AWG	Stripped wire end or ferrule
Ethernet	Max. 4 cables	Outdoor-rated Cat6 STP(**)	RJ45 connector
Soft shutdown switch(***)	2 wires	14 AWG	Stripped wire end or ferrule



NOTE: (*) If utilizing both upper and lower landings, the maximum DC input power path wire size is 4/0 AWG. (**) The required Ethernet cable type depends upon the cable run length. Refer to [Ethernet Requirements](#) for details. (***) Soft shutdown switch is an optional feature.

Connectivity 5

A consistently strong cellular signal is needed before installers can activate the vehicle charging station. Weak or sporadic signal can affect crucial aspects of the charging station, including:

- Accuracy in reporting
- Ability for drivers to use the mobile app
- Ability for customer support to troubleshoot problems
- Support for advanced features such as Power Management or Waitlist

A strong signal is also required for the ChargePoint Assure maintenance and management programs.

ChargePoint stations use cellular data connections to reach ChargePoint Cloud Services. This allows secure, PCI-compliant data connections without requiring any other form of internet connectivity at an install site or imposing additional network management responsibilities on a site host.

Each station has its own cellular connection.

Signal Strength and Quality

You must use a cellular signal detection device (such as a Siretta Snyder LTE or equivalent) to take signal strength readings at the exact proposed mounting location of the charging station. If the charging station does not have its own cellular connection, take the signal strength reading at the proposed mounting location of the gateway station.

In North America, ChargePoint products all support LTE bands 2, 4, and 5. The most commonly supported carriers to check during site evaluation are:

- US: AT&T, T-Mobile, and Verizon
- Canada: Rogers, Telus, and Bell

You must test the LTE signal strength at the proposed mounting location of every station and ensure the location meets the minimum RSRQ at -12.5 dB or better, for RSRP measured at -90 dBm or better. Refer to the graph for acceptable combinations.



NOTE: Cellular signal strength is measured in dBm, a logarithmic unit expressed as a negative number. Because dBm values are negative, a value closer to zero indicates a stronger signal. For example, -70 dBm represents a stronger signal than -85 dBm, while -90 dBm indicates a weaker signal than both.

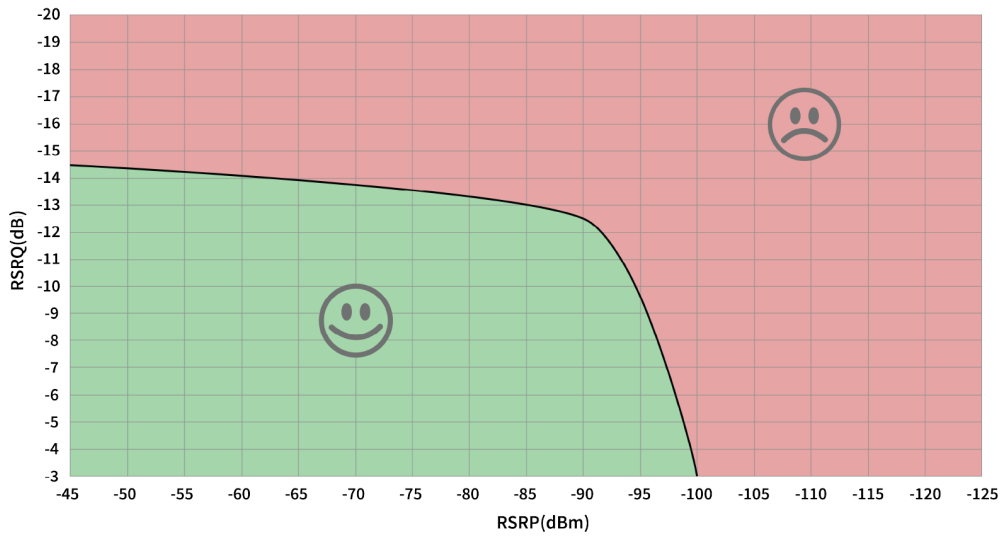

If the signal strength is weaker than this, take cellular readings at the location where any cellular signal booster antennas will be installed. Ensure enough signal exists for that repeater model. Install repeaters to boost the strength of the cellular signals. Repeaters are often required when installing charging stations in an underground garage or enclosed parking structure.

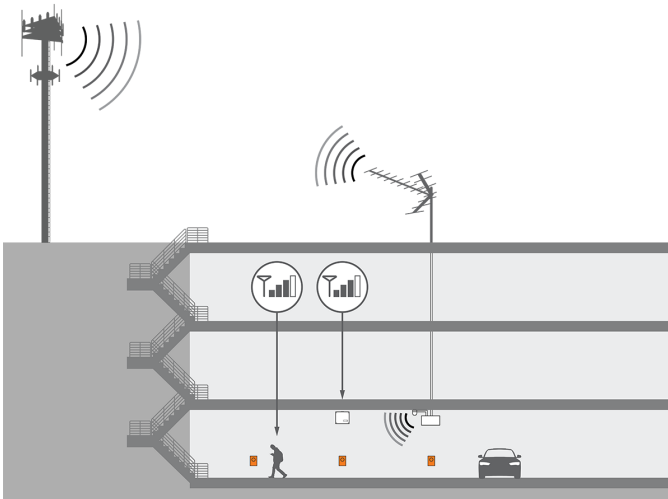
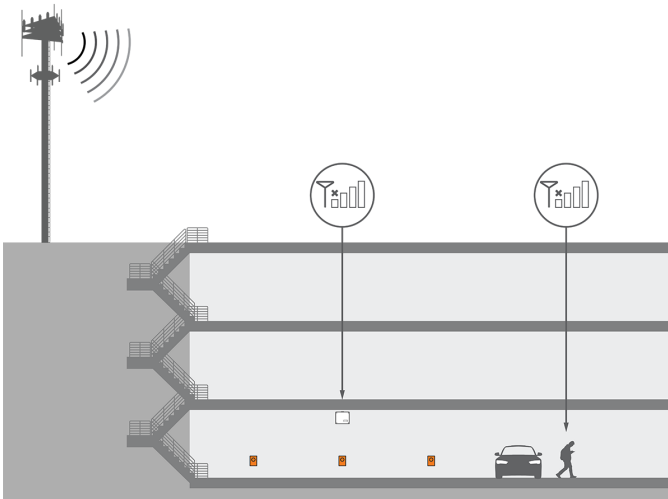

For other regions, or if the site does not have strong signal on these bands, contact your ChargePoint representative for additional solutions.

ChargePoint strongly recommends a consultation with a cellular connectivity specialist before all installations. A consultation can verify:

- Service with a supported carrier on a supported LTE band
- Available signal and local noise levels on applicable bands
- Site changes to correctly meet your needs, both for station bandwidth and other phone coverage for customer or tenant satisfaction

Repeaters

Some sites require repeaters to ensure strong signal to all stations. If a repeater is required, look for a model with these features:

- Specifically LTE-compatible on the listed bands
- Multi-carrier
- Multi-band
- Not already dedicated to FirstNet or other first responder-specific networks
- Auto-gain recommended



NOTE: Do not rely on readings taken with a cell phone when conducting site surveys. Many signal boosters and network extenders may not be compatible with ChargePoint hardware, including certain types of Distributed Antenna Systems (DAS), micro/nano/pico/femto-cells, and carrier- or band-specific signal boosters.

Limited Warranty Information and Disclaimer

The Limited Warranty you received with your charging station is subject to certain exceptions and exclusions. For example, your use of, installation of, or modification to, the ChargePoint® charging station in a manner in which the ChargePoint® charging station is not intended to be used or modified will void the limited warranty. You should review your limited warranty and become familiar with the terms thereof. Other than any such limited warranty, the ChargePoint products are provided "AS IS," and ChargePoint, Inc. and its distributors expressly disclaim all implied warranties, including any warranty of design, merchantability, fitness for a particular purposes and non-infringement, to the maximum extent permitted by law.

Limitation of Liability

CHARGEPOINT IS NOT LIABLE FOR ANY DIRECT, INDIRECT, INCIDENTAL, SPECIAL, PUNITIVE OR CONSEQUENTIAL DAMAGES, INCLUDING WITHOUT LIMITATION LOST PROFITS, LOST BUSINESS, LOST DATA, LOSS OF USE, OR COST OF COVER INCURRED BY YOU ARISING OUT OF OR RELATED TO YOUR PURCHASE OR USE OF, OR INABILITY TO USE, THE CHARGING STATION, UNDER ANY THEORY OF LIABILITY, WHETHER IN AN ACTION IN CONTRACT, STRICT LIABILITY, TORT (INCLUDING NEGLIGENCE) OR OTHER LEGAL OR EQUITABLE THEORY, EVEN IF CHARGEPOINT KNEW OR SHOULD HAVE KNOWN OF THE POSSIBILITY OF SUCH DAMAGES. IN ANY EVENT, THE CUMULATIVE LIABILITY OF CHARGEPOINT FOR ALL CLAIMS WHATSOEVER RELATED TO THE CHARGING STATION WILL NOT EXCEED THE PRICE YOU PAID FOR THE CHARGING STATION. THE LIMITATIONS SET FORTH HEREIN ARE INTENDED TO LIMIT THE LIABILITY OF CHARGEPOINT AND SHALL APPLY NOTWITHSTANDING ANY FAILURE OF ESSENTIAL PURPOSE OF ANY LIMITED REMEDY.

FCC Compliance Statement

This equipment has been tested and found to comply with the limits for a Class B digital device, pursuant to part 15 of the FCC Rules. These limits are designed to provide reasonable protection against harmful interference when the equipment is operated in a residential installation. This equipment generates, uses, and can radiate radio frequency energy and, if not installed and used in accordance with the instruction manual, may cause harmful interference to radio communications.

Important: Changes or modifications to this product not authorized by ChargePoint, inc., could affect the EMC compliance and revoke your authority to operate this product.

Exposure to Radio Frequency Energy: The radiated power output of the 802.11 b/g/n radio and cellular modem (optional) in this device is below the FCC radio frequency exposure limits for uncontrolled equipment. The antenna of this product, used under normal conditions, is at least 20 cm away from the body of the user. This device must not be co-located or operated with any other antenna or transmitter by the manufacturer, subject to the conditions of the FCC Grant.

ISED (formerly Industry Canada)

This device complies with the licence-exempt RSS standard(s) of Innovation, Science and Economic Development Canada (ISED). Operation is subject to the following two conditions: (1) this device may not cause interference, and (2) this device must accept any interference, including interference that may cause undesired operation of the device.

Cet appareil est conforme aux flux RSS exemptés de licence d'Innovation, Sciences et Développement économique Canada (ISDE). L'exploitation est autorisée aux deux conditions suivantes : (1) l'appareil ne doit pas produire de brouillage, et (2) l'utilisateur de l'appareil doit accepter.

Radiation Exposure Statement: This equipment complies with the IC RSS-102 radiation exposure limits set forth for an uncontrolled environment. This equipment should be installed and operated with a minimum distance of 20 cm between the radiator and your body.

Énoncé d'exposition aux rayonnements: Cet équipement est conforme aux limites d'exposition aux rayonnements ioniques RSS-102 Pour un environnement incontrôlé. Cet équipement doit être installé et utilisé avec un Distance minimale de 20 cm entre le radiateur et votre corps.

FCC/IC Compliance Labels

Visit chargepoint.com/labels.