

# Express Solo

One Platform, Infinite Possibilities

Installation Guide



# IMPORTANT SAFETY INSTRUCTIONS

## SAVE THESE INSTRUCTIONS

This manual contains important instructions for ChargePoint® products that shall be followed during installation, operation and maintenance of each product.

### WARNING:



1. **Read and follow all warnings and instructions before servicing, installing, or operating the ChargePoint® product.** Install and operate only as instructed. Failure to do so may lead to death, injury, or property damage, and will void the Limited Warranty.
2. **ChargePoint recommends that installation, commissioning, and break-fix services be performed by a licensed electrician who is also a ChargePoint-certified technician.** These systems operate at high voltage, and without strict adherence to safety protocols, proper protective equipment, and ChargePoint technical guides, there is significant risk to people, equipment, and the environment. Please ensure full compliance with all applicable local and national buildings, electrical, and safety codes.
3. **Always ground the ChargePoint product.** A touch current of >3.5 mA AC RMS is possible in case of a fault condition of loss of electrical continuity of the earthing conductor. Failure to ground the product can lead to risk of electric shock. The product must be connected to a grounded, metal, permanent wiring system, or an equipment grounding conductor shall be run with circuit conductors and connected to the equipment grounding terminal or lead on the Electric Vehicle Supply Equipment (EVSE). Connections to the EVSE shall comply with all applicable codes and ordinances.
4. **Install the ChargePoint product using a ChargePoint-approved method.** Failure to install on a surface that can support the full weight of the product can result in death, personal injury, or property damage. Inspect the product for proper installation before use.
5. **The product is not suitable for use in Class 1 hazardous locations, such as near flammable, explosive, or combustible vapors or gases.**
6. **Supervise children near this device.**
7. **Do not put fingers into the electric vehicle connector or connector adapter. Do not touch fingers to charging rails.**
8. **Do not use this product if any cable is frayed, has broken insulation, or shows any other signs of damage.**
9. **Do not use this product if the enclosure, the flexible output cable, the vehicle inlet, the electric vehicle connector, or the electric vehicle connector adapter is broken, cracked, open, or shows any other signs of damage. Do not use this product if internal parts are accessible, including wiring.**
10. **Wire and wire terminal information are provided in the ChargePoint product Site Design Guide and Installation Guide.**

11. **Torques for installation of wire terminals are provided in the ChargePoint product Installation Guide.**
12. **The ChargePoint product maximum operating temperature is 50 °C (122 °F).**
13. **Do not use an electric vehicle connector adapter with any charger or EV that is capable of exceeding the adapter's rated voltage of current capacity. Some EVs and EVSE combinations are capable of multiple voltages or limited durations of current overloading designed for normal EVSE-to-EV connections. Use of an electric vehicle connector adapter in these situations could result in unsafe conditions such as fire, burns, or exposure of high voltage.**



**IMPORTANT:** Under no circumstances will compliance with the information in a ChargePoint guide such as this one relieve the user of the responsibility to comply with all applicable codes and safety standards. This document describes approved procedures. If it is not possible to perform the procedures as indicated, contact ChargePoint. ChargePoint is not responsible for any damages that may result from custom installations or procedures not described in this document or that fail to adhere to ChargePoint recommendations.

## Warranty Implication



**IMPORTANT:** Please be advised that all installation, commissioning, and break-fix services must be performed by a ChargePoint-certified technician. Engaging non-certified personnel for these services will result in warranty implications, as doing so constitutes a breach of policy.

## Support Services

<https://www.chargepoint.com/legal/support-services>

For more information about ChargePoint's training and certification program, visit <https://www.chargepoint.com/partners/training-certification>

## Product Disposal

**Applicable to NA** - Do not dispose of as part of unsorted domestic waste. Inquire with local authorities regarding proper disposal. Product materials are recyclable as marked.



**Applicable to EU** - To comply with Directive 2012/19/EU of the European Parliament and of the Council of 4 July 2012 on waste electrical and electronic equipment (WEEE), devices marked with this symbol may not be disposed of as part of unsorted domestic waste inside the European Union. Enquire with local authorities regarding proper disposal. Product materials are recyclable as marked.



## Document Accuracy

The specifications and other information in this document were verified to be accurate and complete at the time of its publication. However, due to ongoing product improvement, this information is subject to change at any time without prior notice. For the latest information, see our documentation online at [ChargePoint Product Reference Documentation](#).

## Copyright and Trademarks

©2013-2026 ChargePoint, Inc. All rights reserved. This material is protected by the copyright laws of the United States and other countries. It may not be modified, reproduced, or distributed without the prior, express written consent of ChargePoint, Inc. ChargePoint and the ChargePoint logo are trademarks of ChargePoint, Inc., registered in the United States and other countries, and cannot be used without the prior written consent of ChargePoint.

## Symbols

This guide and product use the following symbols:



**DANGER:** Risk of electric shock



**WARNING:** Risk of personal harm or death



**CAUTION:** Risk of equipment or property damage



**IMPORTANT:** Critical detail that must be followed to achieve intended results



**NOTE:** Important contextual details or procedural clarifications



**REINSTALL NOTE:** Essential instructions to follow when reinstalling a part or component



Read the manual for instructions



Ground/protective earth

## Illustrations Used in This Document

The illustrations used in this document are for demonstration purposes only and may not be an exact representation of the product. However, unless otherwise specified, the underlying instructions are accurate for the product.

# Contents

IMPORTANT SAFETY INSTRUCTIONS .....	i
Revision History .....	vi
<b>1 Introduction .....</b>	<b>1</b>
About This Guide .....	1
Express Solo Overview .....	1
Product Guides .....	8
Questions .....	8
<b>2 Prepare for Installation .....</b>	<b>9</b>
General Instructions and Notes .....	9
Check Site Readiness .....	10
Check Electrical Readiness .....	10
Bring These Tools and Resources .....	11
Packaging .....	13
Disconnect Power .....	17
<b>3 Mount Express Solo .....</b>	<b>19</b>
Wire Entry Overview .....	19
Cable Jigs Overview .....	21
Pull and Test AC Input, DC BUS, and External DC Output Wires .....	22
Prepare AC Input and Neutral Wires .....	23
Prepare External DC Output and DC BUS Wires .....	31
Finalize Wire Preparation .....	35
Open Doors and Remove Safety Covers .....	36
Connect Charging Cables to Cable Management System .....	42
Lift Assembly .....	42
Mount Assembly .....	45
<b>4 Connect Wires .....</b>	<b>50</b>
Wire Terminal and Bus Bar Locations .....	50
Unwrap Wires .....	55
Connect AC Input Wires .....	55
Connect AC Protective Earth (PE) Wires .....	55
Connect DC BUS Wires .....	56
Connect External DC Output Wires .....	57

- Connect DC PE/Ground Wires ..... 58
- Pull Remaining Wires ..... 59
- Connect 48 V DC Wires ..... 60
- Connect Ethernet Cables ..... 65
- Connect Door Interlock Sensor and Soft Shutdown Switch Wires ..... 69
- Connect Safety Hub Wires ..... 72
- Connect Shunt Trip Wires ..... 75
  
- 5 Set Up Charging Cables ..... 76**
  - Install Overhead CMK (if applicable) ..... 76
  - Install Charging Cable Tetherballs ..... 79
  - Suspend Charging Cables ..... 81
  
- 6 Complete the Install ..... 85**
  - Complete the Installation Checklist ..... 85
  - Reinstall Safety Shields ..... 85
  - Close Up Express Solo ..... 86
  
- A Appendix: Low Clearance Forklift Bracket Lift ..... 87**
  
- B Appendix: Set Up Express Solo ..... 88**
  - Power On ..... 88
  - Set Up Express Solo ..... 89

# Revision History

This page provides a summary of revisions made, listing the month and year of each update along with a brief description of the changes made.

Month & Year	Description
May 2026	The following updates were made: <ul style="list-style-type: none"><li>• Replace all references to "HV" and "LV" with specific name of interface or wire.</li><li>• Replace "DC BUS (EXT A)" with "DC BUS (intake side)".</li><li>• Replace "DC BUS (EXT C)" with "DC BUS (exhaust side)".</li><li>• Revised <a href="#">Mount Express Solo</a> chapter.</li><li>• Revised <a href="#">Connect 48 V DC Wires</a>.</li><li>• Revised <a href="#">Connect Ethernet Cables</a>.</li><li>• Revised <a href="#">Connect Door Interlock Sensor and Soft Shutdown Switch Wires</a>.</li><li>• Revised <a href="#">Connect Safety Hub Wires</a>.</li><li>• Revised <a href="#">Close Up Express Solo</a>.</li></ul>
Oct 2025	Update HV DC nomenclature, wire specifications, and Ethernet shield grounding requirement.
Aug 2025	Early access draft - initial release.

# Introduction 1

This section defines the purpose of this guide and provides an introduction to the ChargePoint® Express Solo.

## About This Guide

This guide provides instructions for installing the Express Solo. It covers preparation requirements, mounting and anchoring procedures, electrical and communication connections, commissioning steps, and verification tasks needed to place the station into service.

This guide is intended for licensed electricians, installation contractors, and construction professionals responsible for installing Express Solo equipment in accordance with local codes and ChargePoint requirements.

## Express Solo Overview

Express Solo is a product within the Express DC fast charging platform. Express Solo operates as both a standalone charging station and a power cabinet. It accepts AC input power, converts it to DC, and delivers power to two integrated charging cables. It can also simultaneously supply power to downstream EVSEs such as external Power Link charging dispensers.

For information on Power Link charging dispensers and other modular EVSEs in the ChargePoint Express platform, refer to the Express platform documents at [ChargePoint Product Reference Documentation](#).

# Exterior Parts

The following shows an exterior view of the Express Solo.

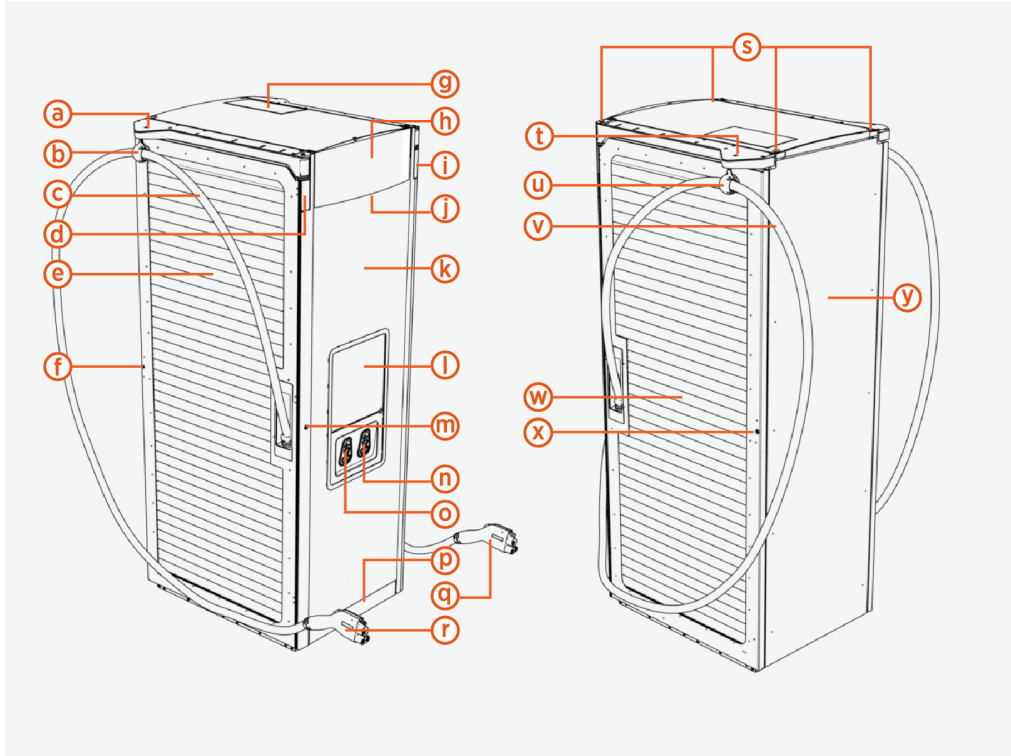

Ref	Part	Ref	Part
(a)	Cable management system, left	(n)	Holster, right
(b)	Tetherball, left	(o)	Holster, left
(c)	Charging cable, left	(p)	Bottom plate
(d)	Status LED, left	(q)	Charging connector, right
(e)	Exhaust (left) door with airflow vents	(r)	Charging connector, left
(f)	Exhaust door lock	(s)	Lifting points
(g)	Smart Antenna	(t)	Cable management system, right side
(h)	Logo plate (customizable)	(u)	Tetherball, right
(i)	Status LED, right	(v)	Charging cable, right
(j)	Area downlight (front – illumination side)	(w)	Intake (right) door with airflow vents
(k)	Display door (with customizable vinyl)	(x)	Intake door lock
(l)	Display/CCOM* assembly (display side)	(y)	Rear panel
(m)	Display door lock		

\* Control and Communication Module

---

## Cable Management System

Express Solo is available with several cable management options:

- **Fixed Tether Point** – Charging cables are suspended from fixed points on left and right sides of the charging station.

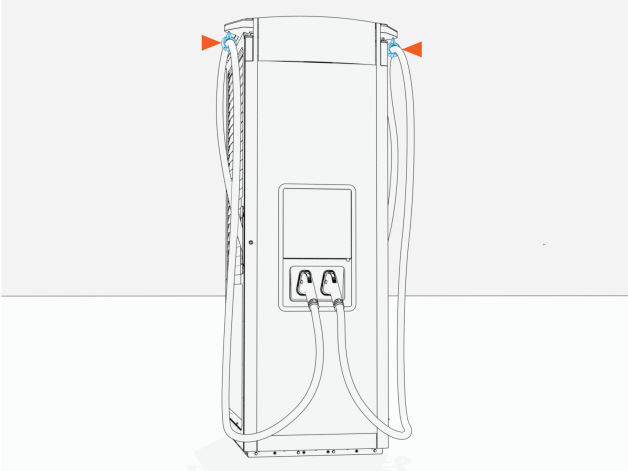

- **Swingarm Cable Management Kit (CMK)** – Moveable arms on left and right sides of the cabinet swing suspended charging cables out and forward for charging and retract cables to rest position between charges.

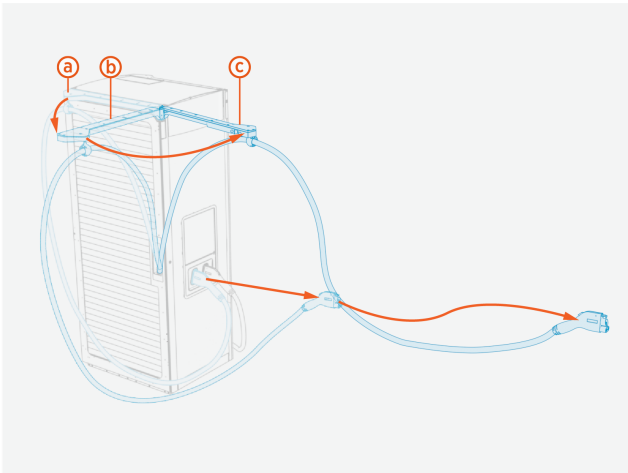

- (a) CMK retracted position
- (b) CMK half open (maximum side extended) position
- (c) CMK fully open (maximum front extended) position

- **Overhead CMK** – An extendable/retractable tetherball suspends charging cables on poles (or other vertical structure) positioned to the left and right of the station.

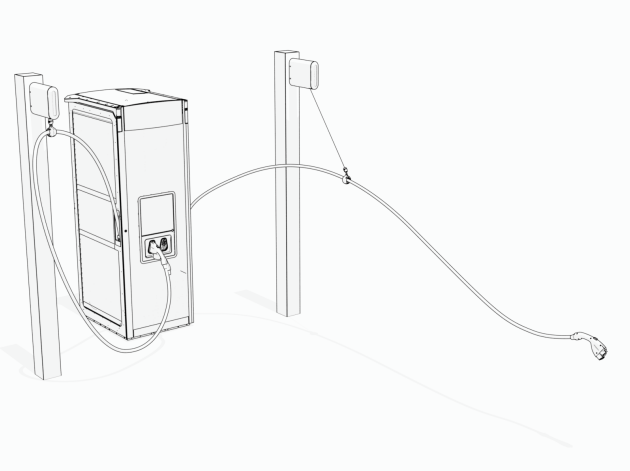

### Interior Parts

The following shows a front interior view of the Express Solo.

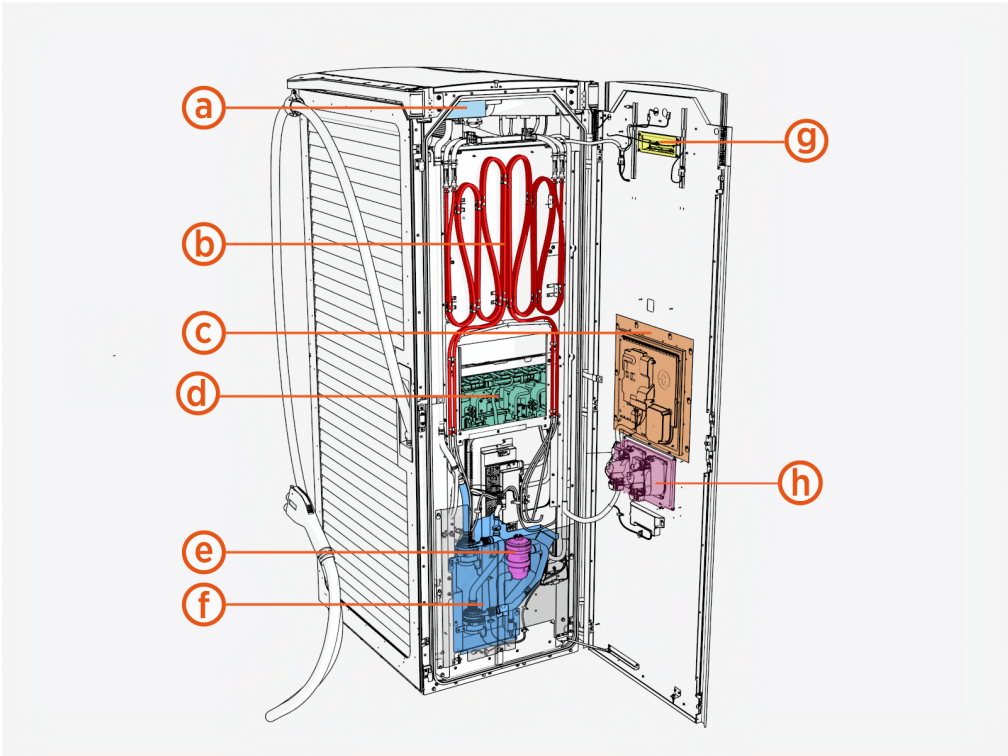

Ref	Part
(a)	Coolant reservoir
(b)	Liquid cooling system
(c)	Display/CCOM Assembly (CCOM side)

Ref	Part
(d)	Neutron modules
(e)	Ion filter
(f)	Coolant circulation pump for liquid cool charging (LCC) loop
(g)	Area downlight (rear housing)
(h)	Holsters

The following shows side interior views of the Express Solo:

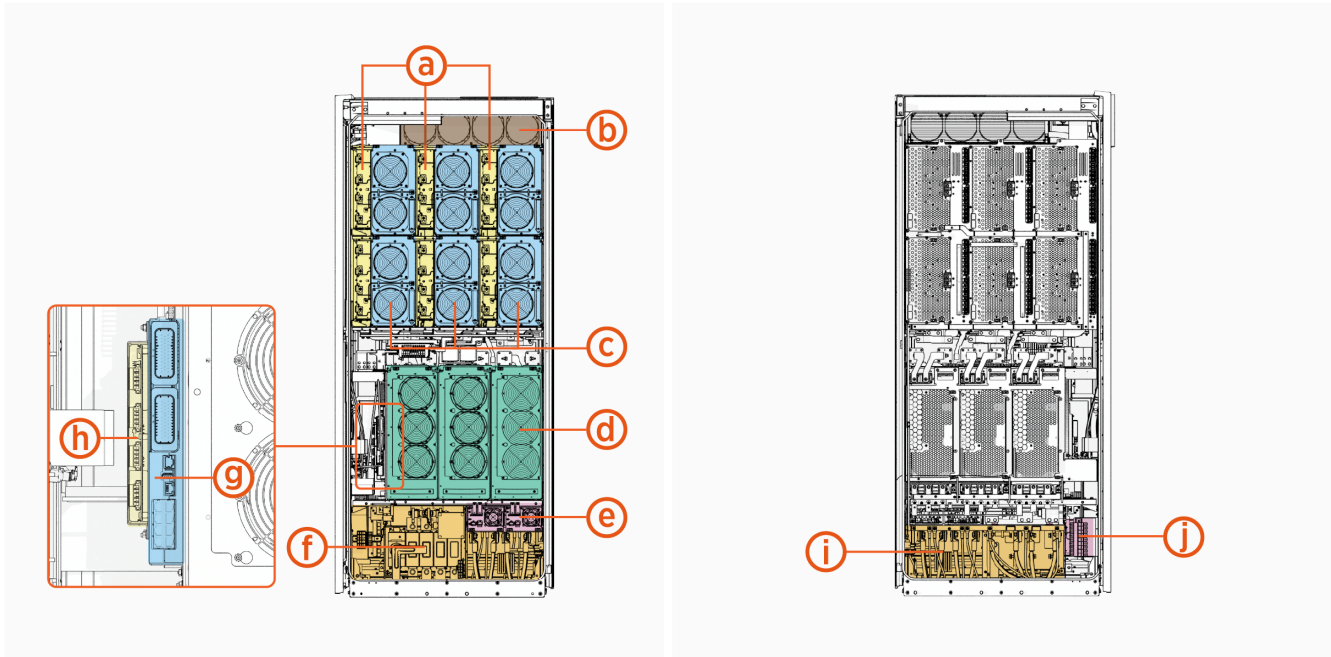

**Intake (Right) Side**

**Exhaust (Left) Side**

Ref	Part	Ref	Part
(a)	Contactor matrix	(f)	Wire terminals and bus bars, intake side
(b)	Liquid cooled charging (LCC) cable fans	(g)	Power Management Controller (PMC)
(c)	DC power modules	(h)	Safety Hub Board (SHB)
(d)	AC power modules	(i)	Wire terminals and bus bars, exhaust side
(e)	Aux power supply (AUX PS) modules	(j)	48 V DC fuse block

## System Description

The Express Solo intakes 3-phase AC grid power and performs power conversion with two types of modules:

- **AC Power Module** – The AC power module converts AC input power to DC output power. Up to three modules can be installed into each Express Solo to scale total power capacity.

- **DC Power Module** – The DC power module is an isolated, bidirectional DC/DC converter that conditions power for delivery to downstream EVs.

The Express Solo has two separate DC power distribution buses, each with its own set of interfaces:

- **DC Grid Bus and DC BUS** – 480 V AC and 400 V AC Express Solo models feature a non-isolated bus called DC Grid that operates at up to 950 V (depending on region and application). These Express Solos are equipped with an interface to its DC Grid Bus, called DC BUS. Two Express Solos may be paired (configured for power sharing) by interconnecting their DC BUSES. 600 V AC Express Solo models do not support DC Grid.
- **DC Output Bus and External DC Outputs** – The DC Output Bus is an isolated DC bus (100–1000 V) that delivers regulated output power to connected EVs. Power flow from the DC Output Bus is routed through the Contactor Matrix, which outputs power across the two integrated charging cables (charging points (CPs)) and to two discrete external DC outputs designated EXT B and EXT D. Each external DC output can supply power to a single input power path of a Power Link charging dispenser.

The Express Solo is equipped with an Auxiliary Power Supply (APS) system:

- **Auxiliary Power Supply (AUX PS) Modules** – Each cabinet includes AUX PS modules that generate 48 V DC power for internal electronics and sub-assemblies within the unit.
- **48 V DC Output** – Express Solo provides two 48 V DC outputs for supplying power to connected Power Link charging dispensers.

The Express Solo features an integrated system that facilitates safe and reliable communication and control:

- **Control and Communications Module (CCOM)** – This module manages various system assemblies such as the UX hardware, display, and communication hardware (cellular). It communicates over Ethernet with external system components and manages charge sessions, user authentication, access control, and communication with ChargePoint Cloud Services.
- **Power Management Controller (PMC)** – The PMC controls power flow within the system. It communicates with the power converters and the contactor matrix to manage the delivery of power to the EV. The PMC supports Ethernet ports for communication with various components like the CCOM, external charging dispensers, and paired Express Solo cabinets to ensure seamless operation. In the event of a fault, the PMC can instruct the power converters to stop power delivery and open the contactors to isolate the power source.
- **Neutrons** – The Neutron module serves as the insulation monitoring device and meter for the charging cables. It detects isolation faults and uses a switch to signal the Safety Hub Board (SHB).
- **Contactor Matrix** – The contactor matrix receives commands from the PMC to open or close the contactors as needed.
- **Safety Hub Board (SHB)** – In addition to processing fault reports from the Neutron, the SHB supports four dispenser ports for performing continuous electrical isolation monitoring of connected Power Link charging dispensers. Any faults detected are reported to the PMC.



**NOTE:** Safety Hub monitoring is not required for all models of Power Link. Contact [ChargePoint](#) for details.

- **Door Interlock Sensor** – Express Solo is equipped with a shunt trip relay that de-energizes the cabinet when doors are open. The PMC reads the door sensor status and shuts down power conversion if one of the doors is open. A safety panel sensor triggers the shunt trip if AC input voltage is present. This ensures the station powers down when the cabinet door is open.

# System Interfaces and Sample Architecture

The following provides a high-level overview of the electrical interfaces of an Express Solo. The diagram also illustrates the interconnections required for an example architecture featuring:

- Two paired Express Solos
- An Express Solo that provides DC output power to the input power paths (A and B) of a Power Link 2000. The Power Link 2000 is equipped with two charging cables (L and R). Note that Power Link 2000 does not require Safety Hub (SH) monitoring.

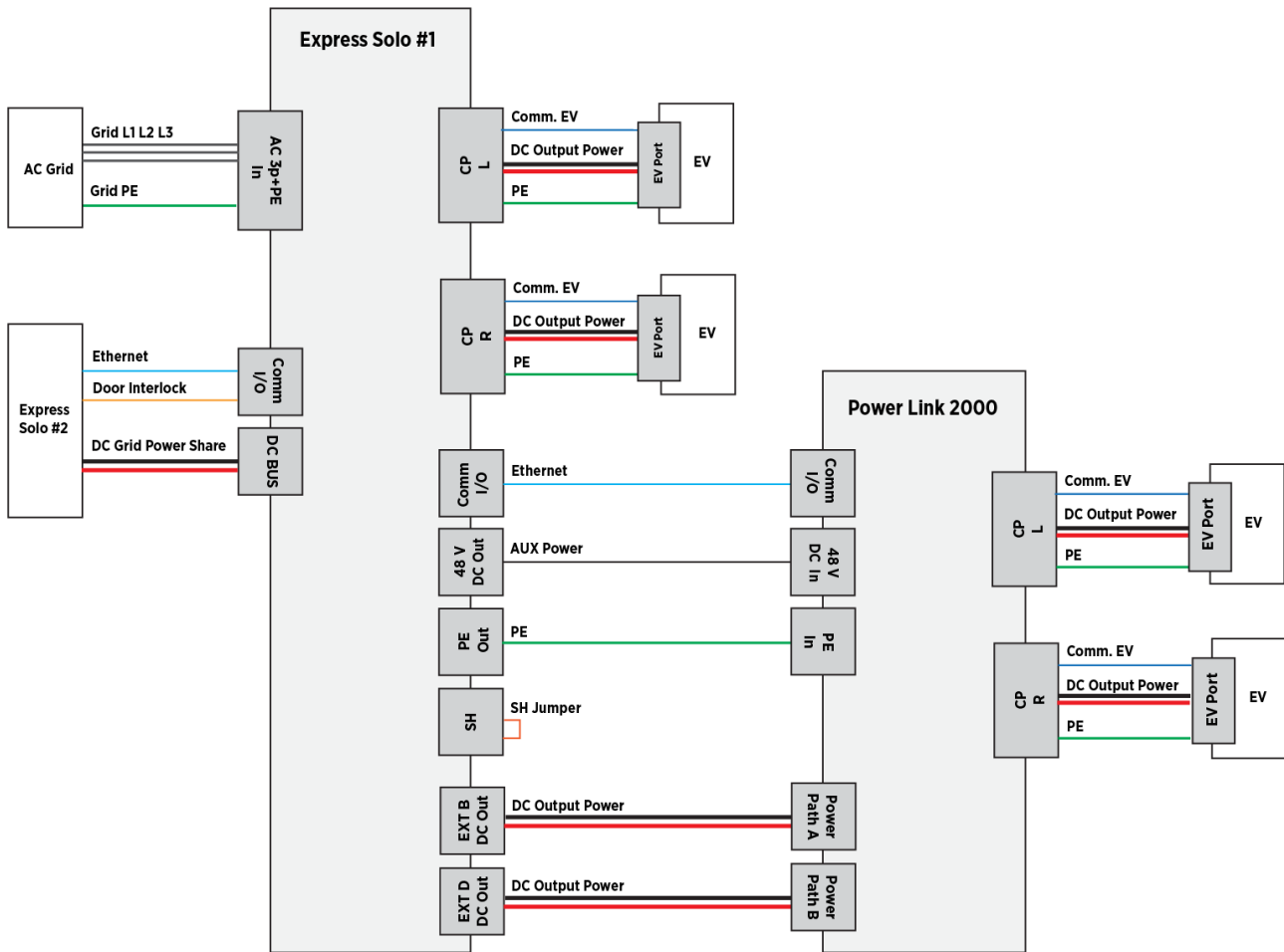

**IMPORTANT:** Express Solo can be configured in many different system architectures, only one of which is shown above. The actual architecture for each site will vary depending on the number of stations, the charging capacity required at each charging station, charging requirements, and other criteria. If you are a site designer, contact a ChargePoint representative for the ChargePoint-approved wiring architecture for your specific project. Systems configured with non-approved wiring between Express Solo and connected EVSEs may not function as expected. If you are an installer, see the site plan for the architecture specific to the site installation project.

# Product Guides

A full suite of guides is available for Express Solo, as summarized below.

Document	Content	Primary Audiences
Datasheet	Full station specifications	Site designer, installer, and station owner
Site Design Guide	Civil, mechanical, and electrical guidelines to scope and construct the site	Site designer or engineer of record
Construction Signoff Form	Checklists used by contractors to ensure the site is correctly completed and ready for product installation	Site construction contractor
Installation Guide	Anchoring, wiring, and powering on	Installer
Operation and Maintenance Guide	Operation and preventive maintenance information	Station owner, facility manager, and technician
Service Guide	Component replacement procedures, including optional components	Service technician
Declaration of Conformity	Statement of conformity with directives	Purchasers and public

Access ChargePoint documents at [ChargePoint Product Reference Documentation](#).

## Questions

For assistance, go to [chargepoint.com/support](https://chargepoint.com/support) and contact technical support using the appropriate region-specific number.

# Prepare for Installation 2

Follow all instructions provided in this chapter to prepare for installation.

## General Instructions and Notes



**WARNING:** Do not install or service the charging station in inclement weather. If you work in snow, rain, or wind, you must use a weather-proof shelter that covers all boxes and components.



**CAUTION:** Warranty Limitation

- If the charging station is not installed, commissioned, or serviced by a ChargePoint certified technician using a ChargePoint-approved method, it is *excluded* from all ChargePoint and other warranties and ChargePoint is not responsible.
- You must be a licensed electrician and complete training at <https://www.chargepoint.com/partners/training-certification> to become ChargePoint certified and to access ChargePoint's web-based installer tools or ChargePoint Installer app.



**CAUTION:** Use low torque settings when working with power tools during installation or servicing. Over-torquing can damage the equipment.



**CAUTION:** While installing fasteners inside a product enclosure, make sure not to drop the fasteners inside conduit openings. You may use conduit caps or covers to temporarily cover the conduit openings.



**IMPORTANT:** Ensure that the installation complies with all applicable codes and ordinances.

# Check Site Readiness

Complete this checklist before you install Express Solo.

Express Solo Site Readiness Checklist		
1.	The concrete mount surface is smooth and level.	<input type="checkbox"/>
2.	The concrete pad or concrete surface meets the mounting specifications given in the <i>Express Solo Site Design Guide</i> and/or is inspected and approved by a structural engineer for the product dimensions and weight (as given in the <i>Express Solo Site Design Guide</i> ).	<input type="checkbox"/>
3.	Wires and conduits meet the requirements given in the site drawings.	<input type="checkbox"/>
4.	The electrical equipment is installed and labeled in accordance with the applicable national electrical code — such as NFPA70, the Canadian Electrical Code (CSA No 22.1), IEC 60364, or BS7671, depending on the installation region — and all applicable requirements of the serving electric utility company and the authority having jurisdiction.	<input type="checkbox"/>
5.	The installation site meets the drainage, ventilation guidelines, and clearances given in the <i>Express Solo Site Design Guide</i> .	<input type="checkbox"/>
6.	Sufficient space is available to use a forklift or other lifting equipment, unpack, remove packing materials, and allow two people to freely move throughout the site.	<input type="checkbox"/>
7.	The anchor bolts, conduits, and concrete pad meet the requirements listed below: <ul style="list-style-type: none"> <li>• The anchor bolts are installed, extend 127 mm (5 in) above the concrete pad, and are vertically plumb.</li> <li>• The conduits or armored cables are laid per the conduit layout given in the <i>Express Solo Site Design Guide</i>.</li> <li>• In regions that use conduits, the conduits do not have bell ends, are vertically plumb, and stub up to a height of 13–25 mm (0.5–1 in) above the concrete pad. Conduits with bell ends may interfere with tolerances inside Express Solo.</li> <li>• The concrete pad is fully cured and smooth.</li> </ul>	<input type="checkbox"/>

# Check Electrical Readiness

Refer to the *Express Solo Datasheet* and *Express Solo Site Design Guide* at [ChargePoint Product Reference Documentation](#) for electrical input and output specifications.

## Bring These Tools and Resources

Installing Express Solo requires at least two people. Additionally, the installer must bring the following tools and resources. These are not provided by ChargePoint.



**CAUTION:** Comply with these guidelines to prevent component damage.

- Use tools suitable to torque metric fasteners. All fasteners used on Express Solo are in metric sizes.
- Use the given torque values to tighten the fasteners.
- Ensure that the tools such as torque tool, multimeter, and Ethernet tester are calibrated.

## Tools and Materials



Construction crane

- For standard installation
- Rated for TBD kg (TBD lb)



Forklift with anti-slip forks

- For low clearance installation
- Rated for  $\geq$  TBD kg (TBD lb)
- Fork specifications:
  - Width = TBD mm (TBD in)
  - Thickness  $\leq$  TBD mm (TBD in)



Stepladder



Industrial vacuum cleaner



Wire brush (to remove any residue on anchor bolts)



Safety glasses



Hard hat



Cut-resistant gloves



Cable puller or fish tape



Measuring tape or other tool to measure linear dimensions



Level



Lockout/Tagout equipment



Multimeter (meter and probes rated for 1000 V)



Ethernet tester such as a Klein Tools VDV526-052 VDV LAN Scout Jr. Tester or similar



Conduit cutter (refer to site plans for conduit sizes)



Box cutter

	Wire cutters		Wire strippers
	Lug crimping tool and die		Ethernet (RJ45) connector crimping tool
	Torque wrench		Torque screwdriver
	Shallow socket set (8 mm, 10 mm, 13 mm, 17 mm) and 30 mm deep socket		Hex wrench set
	Torx screwdriver (T20, T30)		T25 Security screwdriver
	Flathead screwdriver set, including 2 mm, 3.5 mm and 5 mm tip for terminal blocks		Phillips head screwdriver set
	Torque paint pen		Permanent marker
	Anti-oxidant joint compound (to make gastight joint between wire and lug) and wire pulling lubricant		Dielectric grease
	Duct seal compound		Paper towel roll
	Cable ties		Cling film (plastic wrap)
	Smartphone with: <ul style="list-style-type: none"> <li>• Internet connectivity</li> </ul>		<ul style="list-style-type: none"> <li>• ChargePoint installer login credentials</li> </ul>
	<ul style="list-style-type: none"> <li>• QR code scanner (usually built into the camera app)</li> </ul>		<ul style="list-style-type: none"> <li>• ChargePointInstaller app</li> </ul>

## Wires and Terminations

Gather all wires and wire terminations required for the installation project. Refer to the *Express Solo Site Design Guide* for general system wire specifications and refer to the site plan for wires and terminations required specifically for the installation project.

## Packaging

Use the following information to transport product packages to the installation site and unpack Express Solo.

### General Instructions and Notes



**WARNING:** The crate is heavy and can cause injury or death if dropped. Do not stand or walk beneath the crate while it is being lifted. Take precautions against the crate tipping or sliding.



**CAUTION:** Always transport and store components in their original packaging. Use appropriate lifting equipment (forklift or crane, lifting straps, and any corresponding attachments and accessories). Ensure the load rating of all lifting equipment is adequate for the weight of the crated components.



**CAUTION:** Keep components in original packaging, free of moisture, and protected from damage until you install or service them at the site. Store all shipments of components in a dry covered location and protect from moisture.



**CAUTION:** To protect the charging cables from damage, keep them wrapped throughout the installation process.



**IMPORTANT:** Leave components in the shipping crate until needed. When removing, protect them from damage (such as scratches) by placing them flat on a blanket or tarp, face up. Do not stand up cover panels, as they may be knocked or blown over. Cover charging connectors to prevent damage or ingress.



**IMPORTANT:** Keep components out of direct sunlight in a cool area until you install them.

### Package Dimensions and Weights

Package	Dimensions (L x W x H)	Max. Weight
Express Solo (Product assembly on shipping pallet)	1.12 x 1.32 x 2.5 m (44.1 x 51.8 x 98.4 in)	TBD
Cable Landing Jig	TBD	TBD
Overhead CMK	0.45 x 0.40 x 0.18 m (17.50 x 15.88 x 7 in)	12 kg (25 lbs)

## Express Solo Package

After uncrating Express Solo, check for the following components:



**NOTE:** For any missing component, [contact ChargePoint](#).

Placeholder Image

- (a)** Express Solo assembly
- (b)** Charging cables (Up to x2, depending on configuration)
- (c)** Hardware box with:
  - i. Eye bolts (x4) - Enables lifting of the assembly
  - ii. Lifting straps (x2) - Enables lifting of the assembly
  - iii. Keys (x2) - Opens the front, intake (left) and exhaust (right) doors
  - iv. M20 anchor nuts (x4) - Secures the assembly to foundation
  - v. M10 nuts (xTBD) - Secures AC input, external DC output, and DC BUS wires to bus bars
  - vi. Door lock plugs (x3) - To plug the door locks at completion of install

## Cable Landing Jig Package

Unpack the Express Solo Cable Landing Jig package and check for the following components:



**NOTE:** For any missing component, [contact ChargePoint](#).

Placeholder Image

- (a) AC cable jig components
- (b) DC cable jig components
- (c) Jig alignment plate

## Overhead CMK Package (Option)

Check the overhead CMK package for the following components:



**NOTE:** For any missing component, contact ChargePoint.

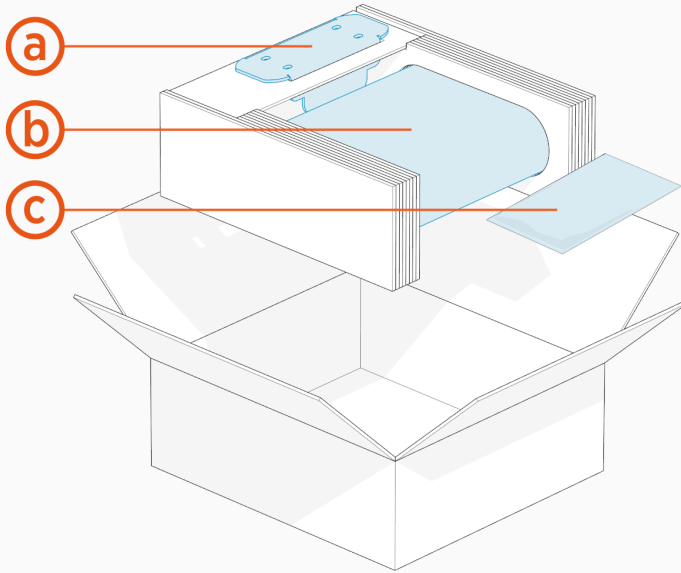

- (a)** Mounting bracket
- (b)** Overhead CMK
- (c)** Hardware kit with M8 hex nuts (x4) and M6 Torx screws (x4)

# Disconnect Power

To disconnect power, complete the following steps:

**DANGER: RISK OF SHOCK**



- Before any procedure, disconnect the power.
- Follow local code and site lockout/tagout procedure to de-energize the station.
- Wait for energy to dissipate (approximately five minutes).
- Keep power off until all covers and panels are reinstalled and the work is complete.

FAILURE TO FOLLOW THESE INSTRUCTIONS CAN RESULT IN SERIOUS INJURY, LOSS OF LIFE, OR PROPERTY DAMAGE.

1. Disconnect power at the site electrical panel.



**NOTE:** Follow standard practice and local code to de-energize the applicable circuit and lock out/tag out the disconnect before proceeding.

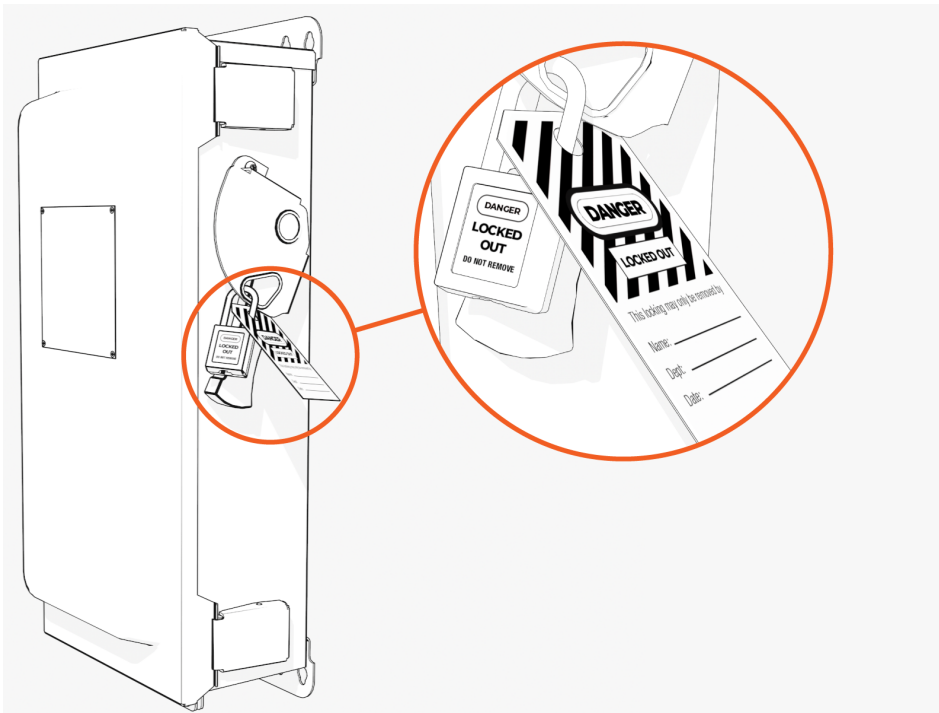

2. Use a multimeter to test that the unit is de-energized.



**IMPORTANT:** Do not reconnect the power after completing physical installation. An authorized commissioning partner will commission, power on, pinpoint, and configure Express Solo after physical installation.

# Mount Express Solo 3

Follow all instructions provided in this section to mount the Express Solo.

## Wire Entry Overview

Below is a sample depiction of Express Solo wire entry via conduit stub-ups. In regions that do not use conduits and/or use armored cables, the cables shall be laid out in a similar pattern.



**NOTE:** The size and quantity of conduits and wires shown below are for illustrative purposes only. The actual quantity and size of conduits and wires for your specific site may vary and shall depend on site specific requirements.

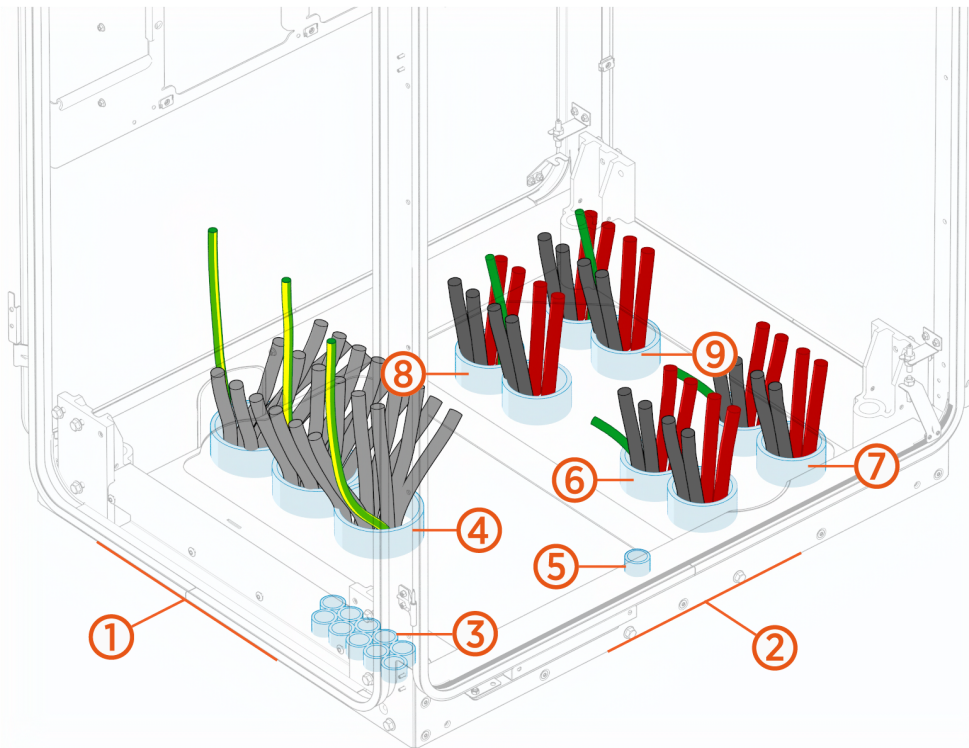

- (1) Cabinet front side
- (2) Cabinet intake (right) side
- (3) 48 V DC, Ethernet, Safety Hub, and door interlock
- (4) AC input
- (5) Shunt trip
- (6) DC BUS (intake side)
- (7) EXT B
- (8) DC BUS (exhaust side)
- (9) EXT D

To view wire landing locations within the cabinet, see [Wire Terminal and Bus Bar Locations](#).

## Cable Jigs Overview

The AC input, external DC output, and DC BUS cables must be pulled through conduit and prepared for connection using two cable jigs. The cable jigs replicate the positions of the bus bars within the Express Solo cabinet and allows the cables to be prepared (cut to correct length and positioned correctly) before the station is positioned and secured to the concrete pad.



**NOTE:** The size and quantity of conduits and wires shown below are for illustrative purposes only. The actual quantity and size of conduits and wires for your specific site may vary and shall depend on site specific requirements. Use the diagram solely to review usage of the cable jigs.

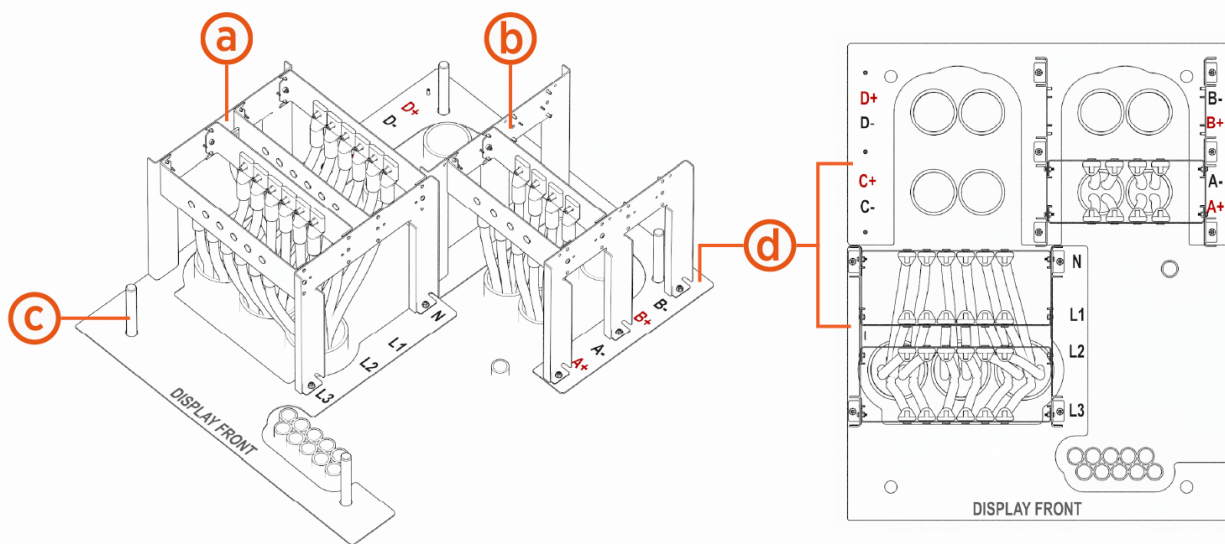

Ref	Part	Function or Definition
(a)	DC cable landing jig	Positions the following external DC output and DC BUS cables for landing on bus bars: <ul style="list-style-type: none"> <li>• DC BUS (intake side), marked A on jig alignment plate</li> <li>• EXT B</li> <li>• DC BUS (exhaust side), marked C on jig alignment plate</li> <li>• EXT D</li> </ul>
(b)	AC input cable landing jig	Positions AC input cables for landing on bus bars
(c)	Anchor bolt	Concrete-embedded anchor bolts (x4)
(d)	Jig alignment plate	Two-part plate that installs over the anchor bolts and serves as a base for the cable jigs

# Pull and Test AC Input, DC BUS, and External DC Output Wires

Follow the procedure below to pull and test AC input wires, DC BUS, and external DC output wires.

1. Install the jig alignment plates over the anchor bolts and conduit stub-ups.



**NOTE:** The jig alignment plates install in two parts.

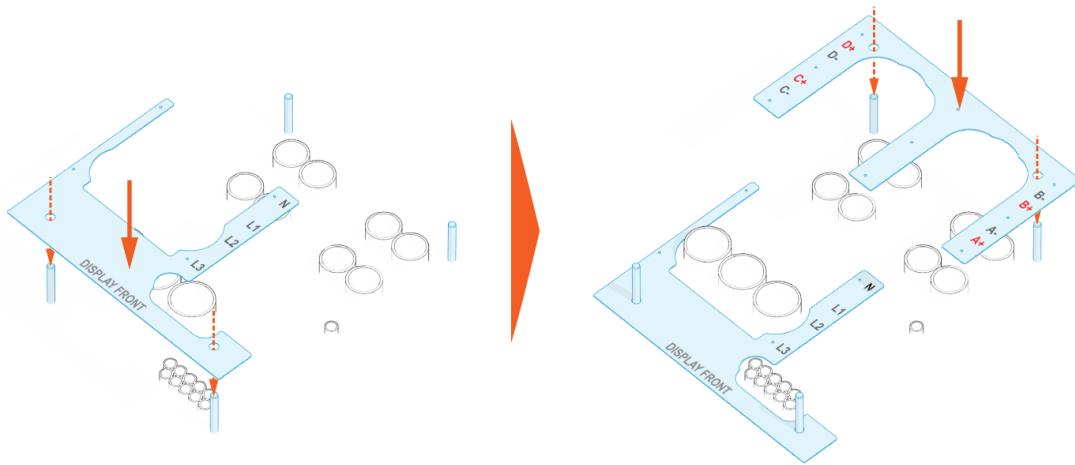

2. Label all wires at both ends.
3. Express Solo supports multiple conduit options. Study the line diagram carefully to understand which wires should be pulled through each conduit.

- Pull the AC input, DC BUS, and External DC output wires through conduit. If necessary, apply a non-conductive wire pulling lubricant.

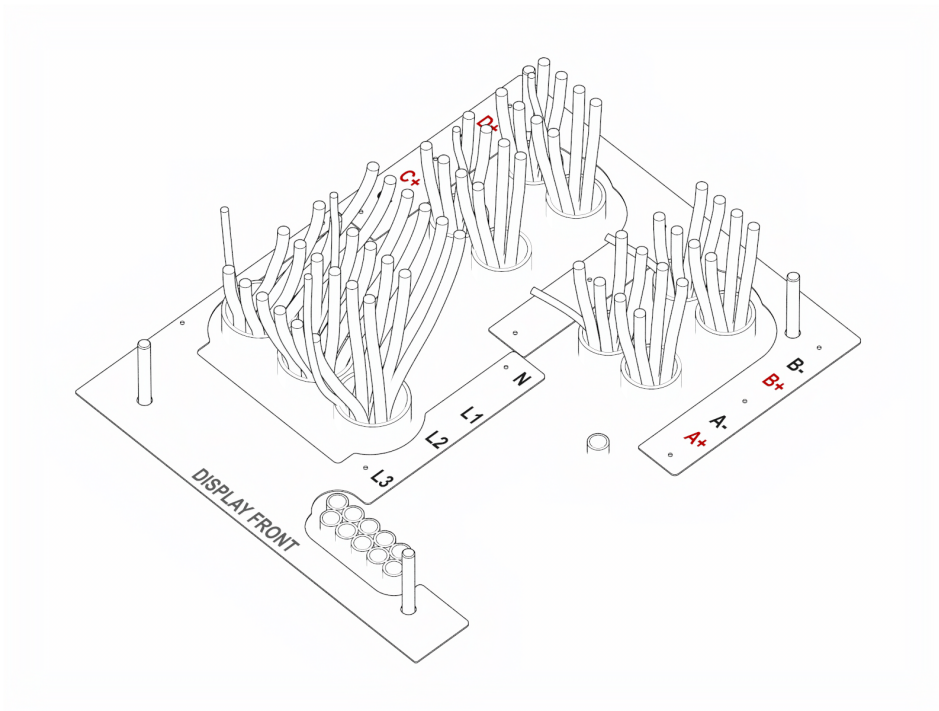

- Perform insulation resistance test on the pulled wires. Refer to the *High Voltage Wire Insulation Resistance Test Field Guide*.
- Wipe off any remains of wire pulling lubricant (if applied).

## Prepare AC Input and Neutral Wires

Follow steps below to prepare AC input and neutral wires using the AC input cable landing jig.

1. Secure each side frames (x2) to the jig alignment plate using provided M6 hex nuts (x2 for each frame). Torque to **5.6 Nm (50 in-lb)**.

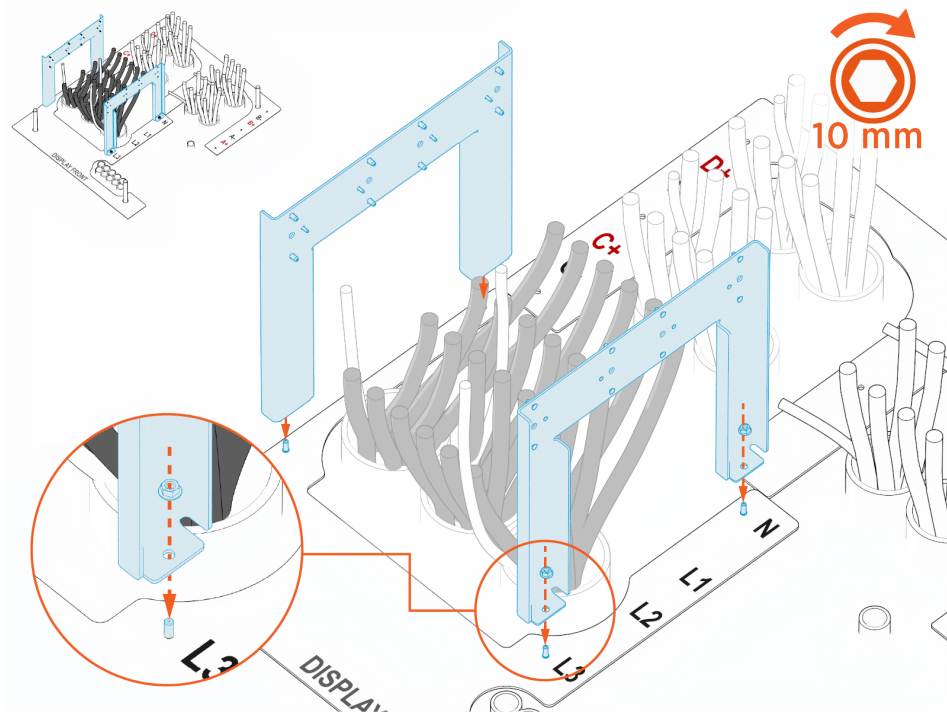

2. If neutral is required, take the following steps to prepare the neutral wires:
  - a. Attach the stud landing bar to the side frame in the neutral (N) position. Secure the bar with provided M6 bolts (x2).

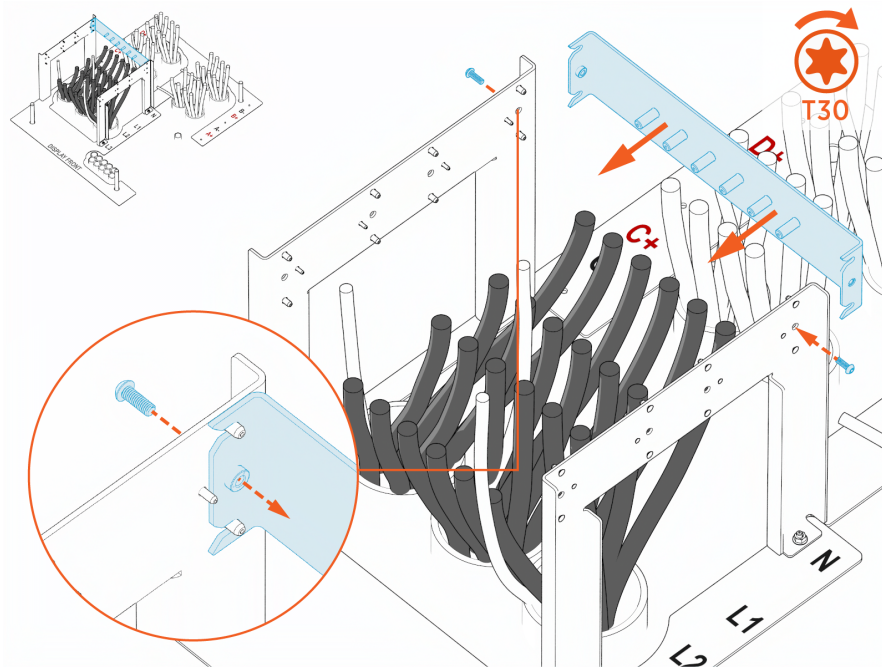

- b. Install the wire lugs on the stud landing bar. Secure each lug with provided M10 hex nut. Hand tighten.



**IMPORTANT:** Ensure all wires lugs are installed vertically the landings studs, with no tilt or skew.

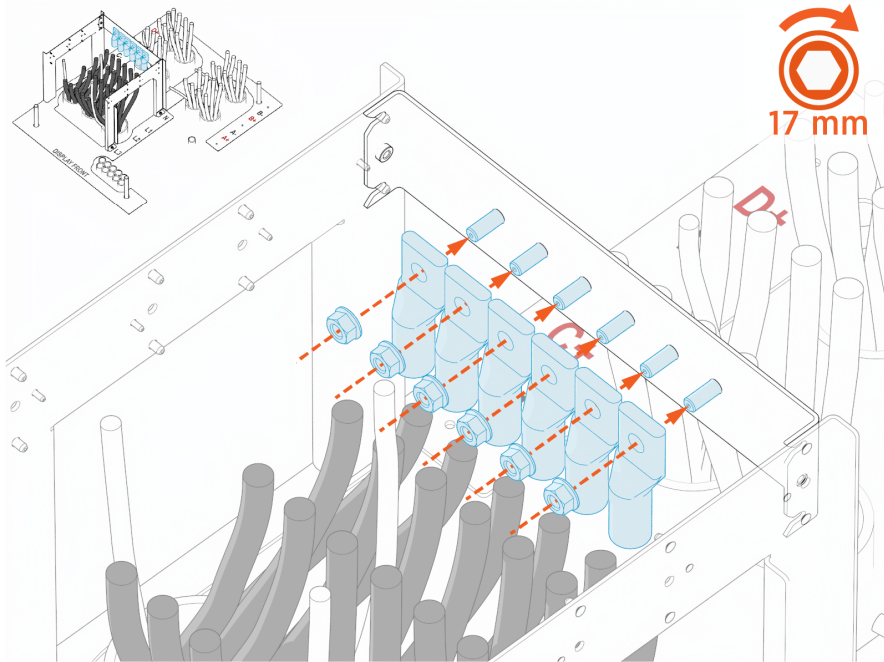

- c. Position the neutral wires next to the lugs. Mark and cut the wires to length.

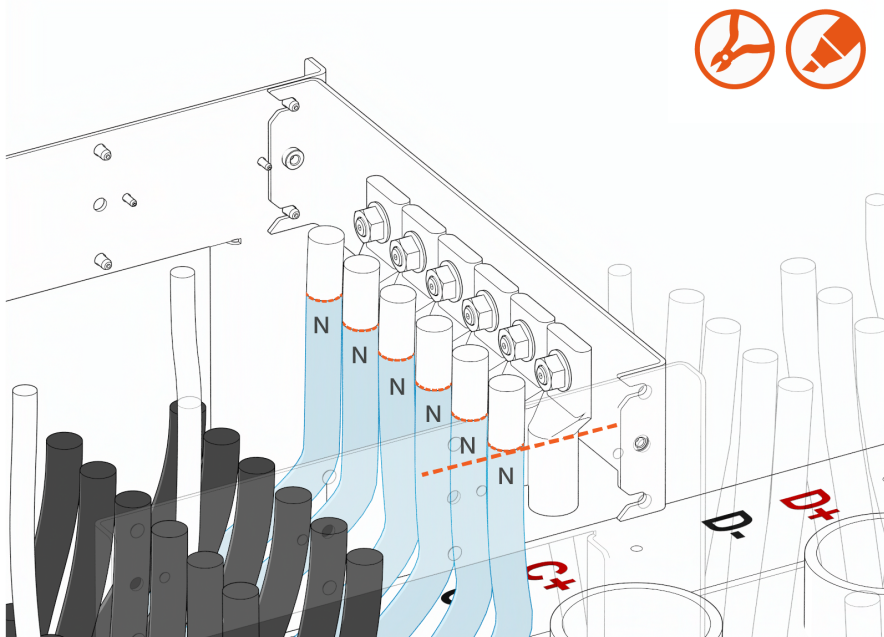

d. Remove the lugs from the stud landing bar.

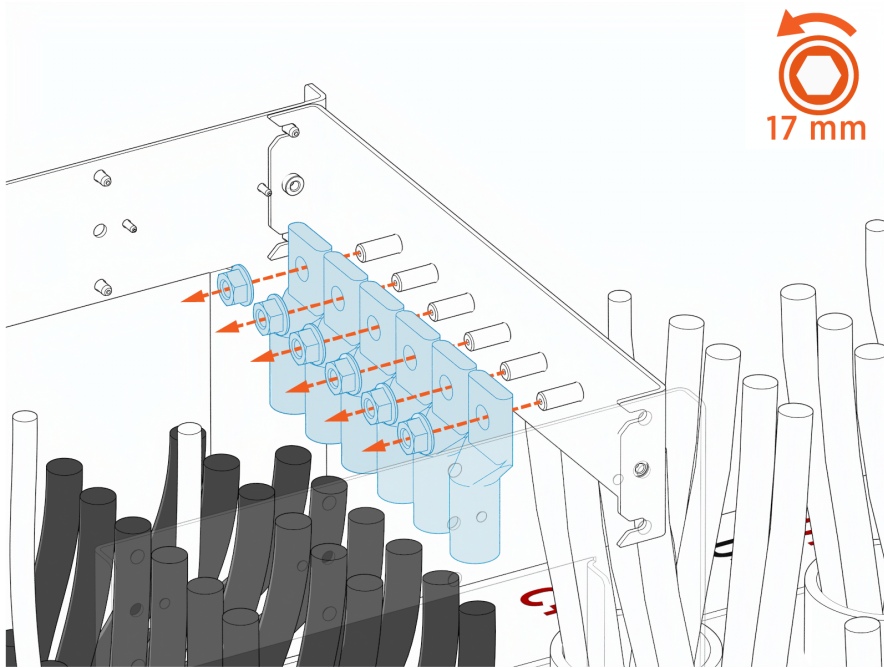

e. Terminate each wire with a lug:

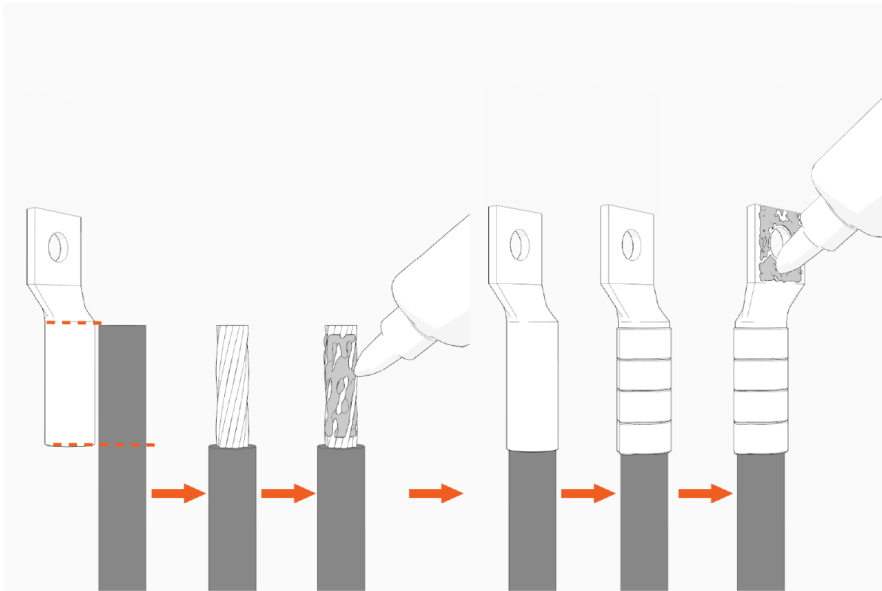

- Mark the lug's barrel height on the cable.
- Strip the wire jacket. Use a suitable wire stripper, such as a Klein tool.
- If recommended by the wire manufacturer or local code, apply an anti-oxidant joint compound to the bare cable to make a gastight joint with the lug.
- Insert the stripped wire end into the lug barrel and crimp it. Use a suitable lug crimping tool and/or die recommended by the lug manufacturer.

f. Stage the terminated wires on the stud landing bar.

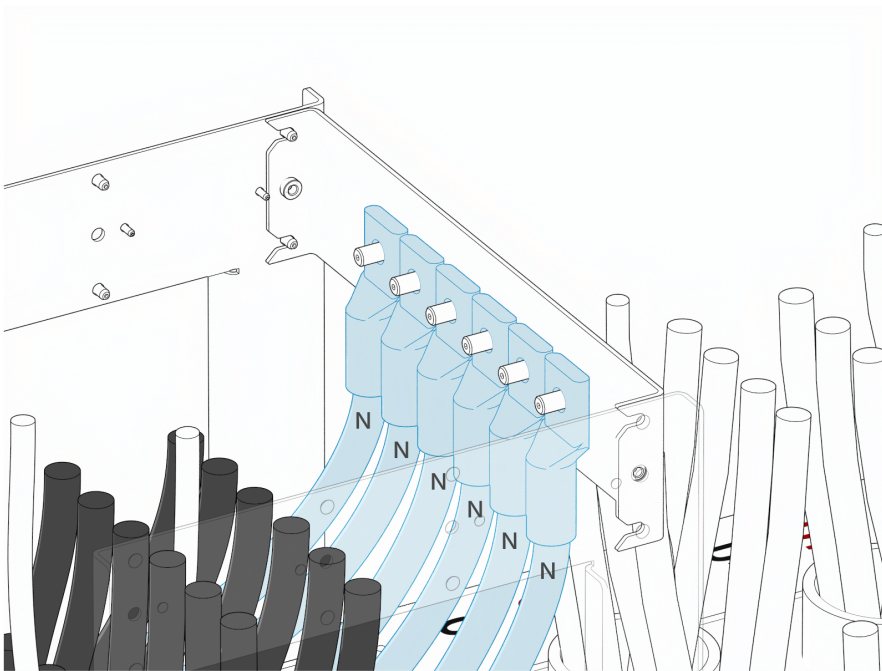

g. Unfasten stud landing bar and remove the bar by pulling it out to the side.

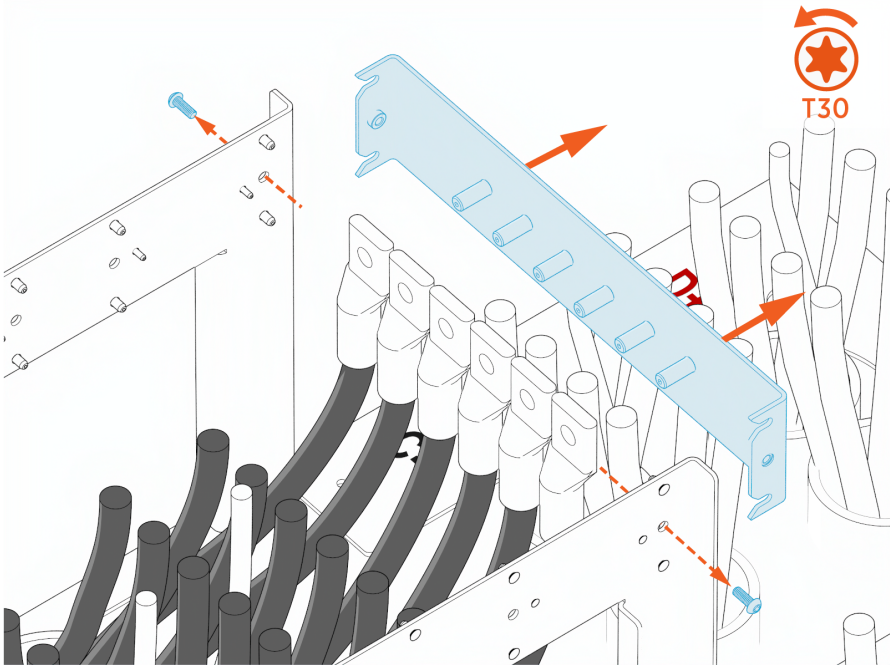

3. Repeat to stage the L1 wires.

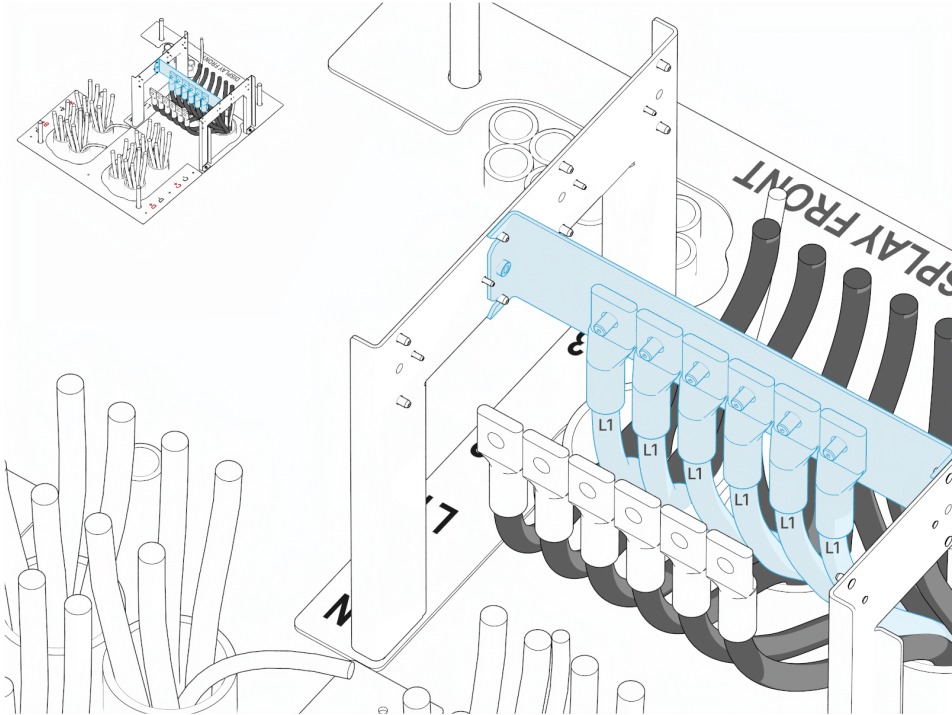

4. Repeat to stage the L2 wires.

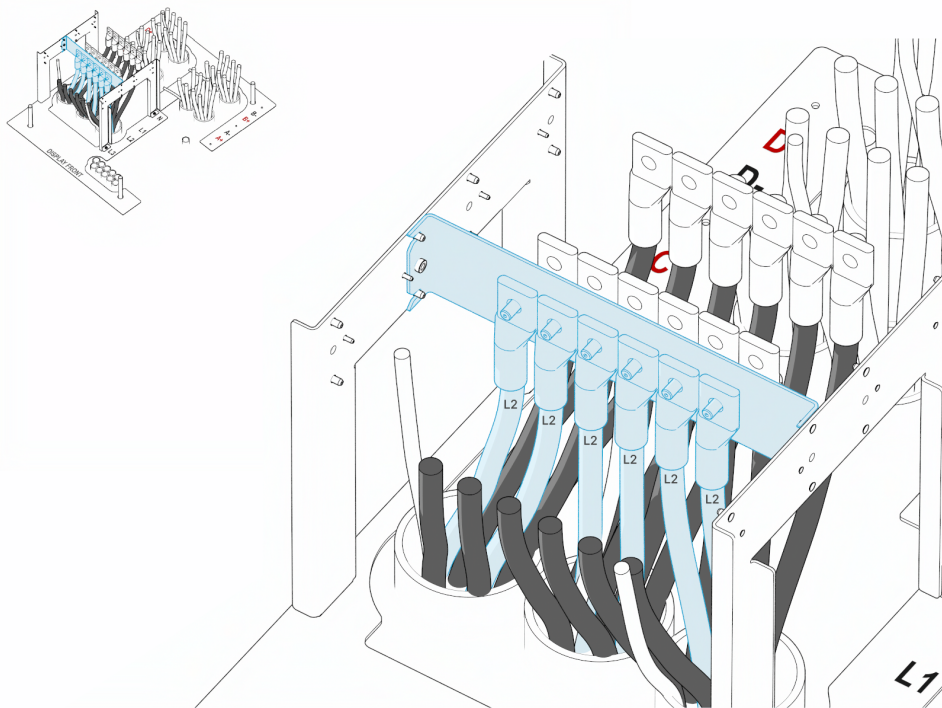

5. Repeat to stage the L3 wires.

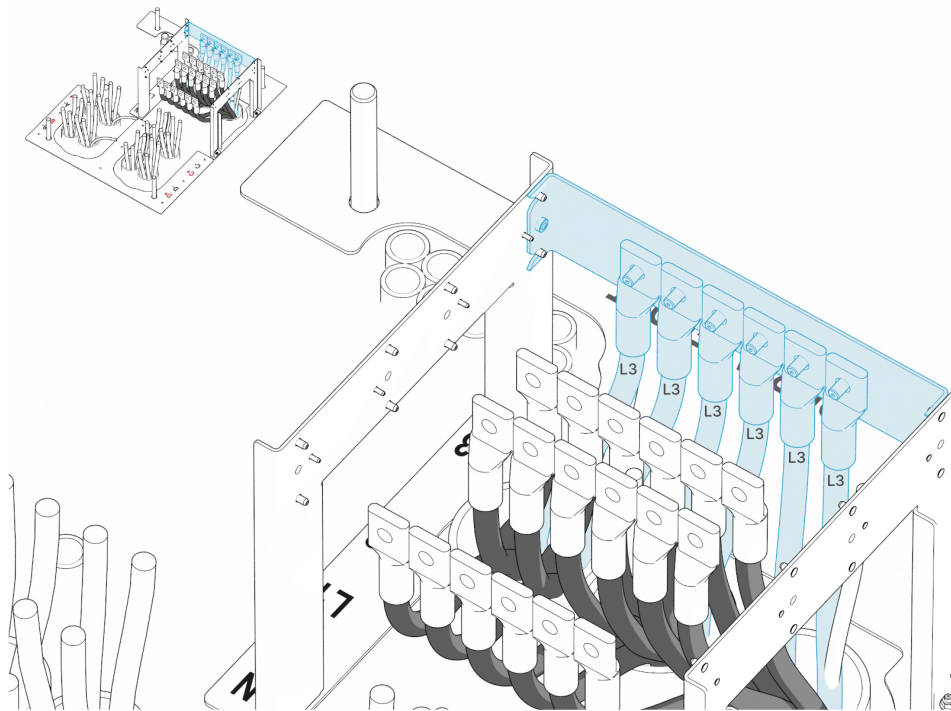

6. Unfasten and remove the side frames from the jig alignment plate.

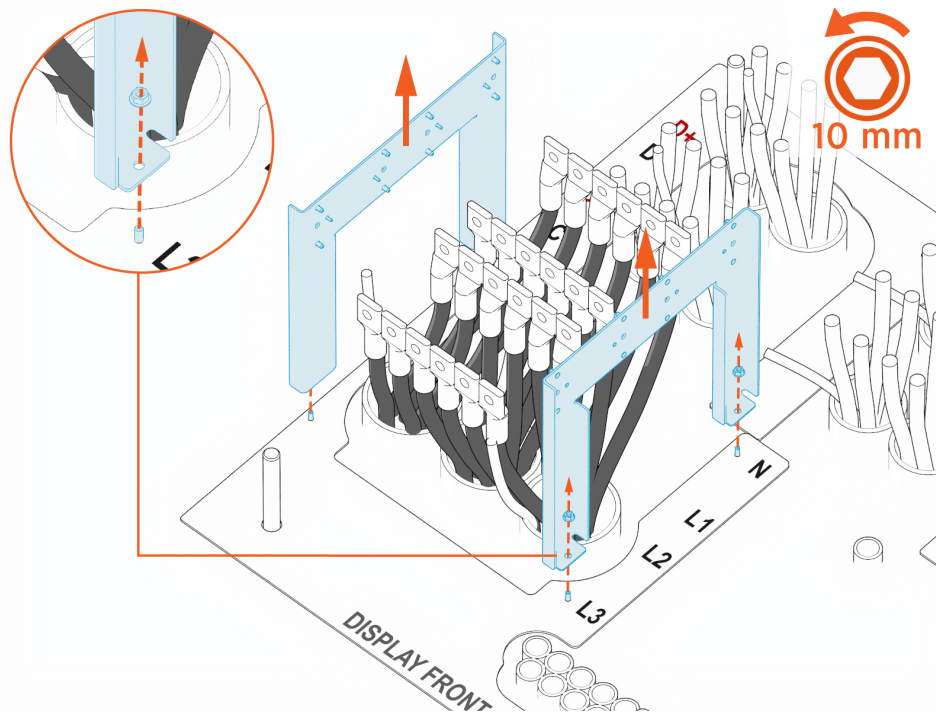

## Prepare External DC Output and DC BUS Wires

If External DC output and DC BUS wires are required, follow steps below to prepare the wires using the DC cable landing jig.

1. Install the side frames (x2) around the exhaust-side DC wire conduits. Secure them to the jig alignment plate using provided M6 hex nuts (x3 for each frame). Torque to **5.6 Nm (50 in-lb)**.

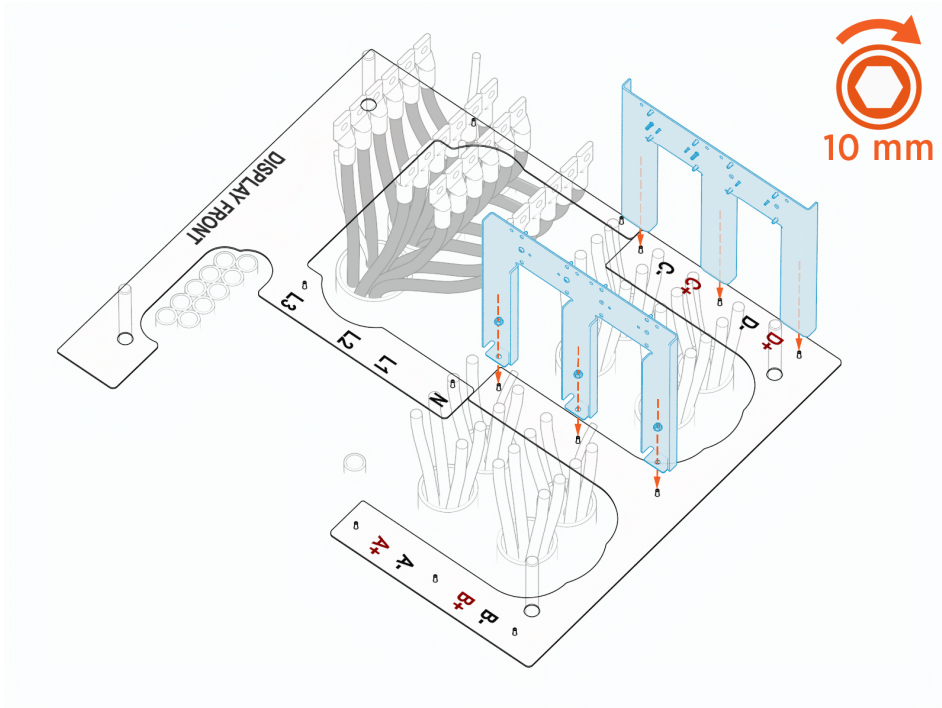

- Using the same procedure described for the AC cable jig, cut, terminate, and stage the exhaust-side DC BUS negative (DC BUS -), DC BUS positive (DC BUS +), EXT D negative (D-), and EXT D positive (D+) wires, working one row at a time. Remove the cable jig when done.



**NOTE:** DC BUS (exhaust side) wires are staged at the locations marked 'C' on the jig alignment plate

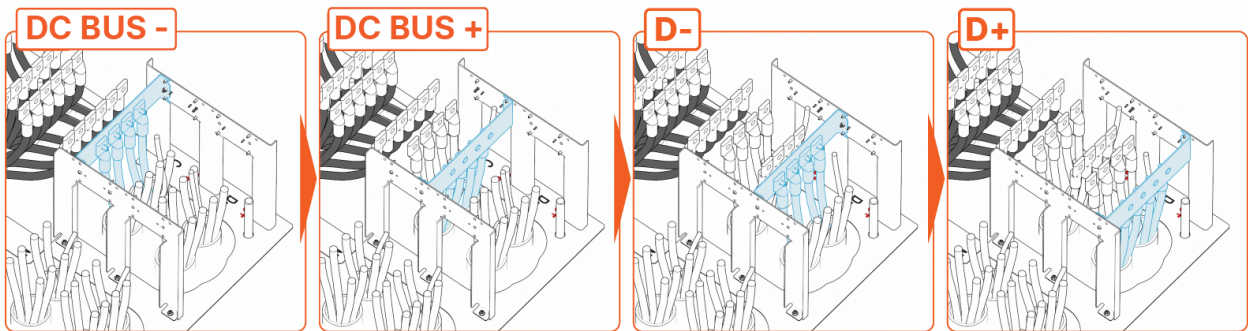

3. Install the side frames (x2) around the intake-side external DC output conduits. Secure them to the jig alignment plate using provided M6 hex nuts (x3 for each frame). Torque to **5.6 Nm (50 in-lb)**.

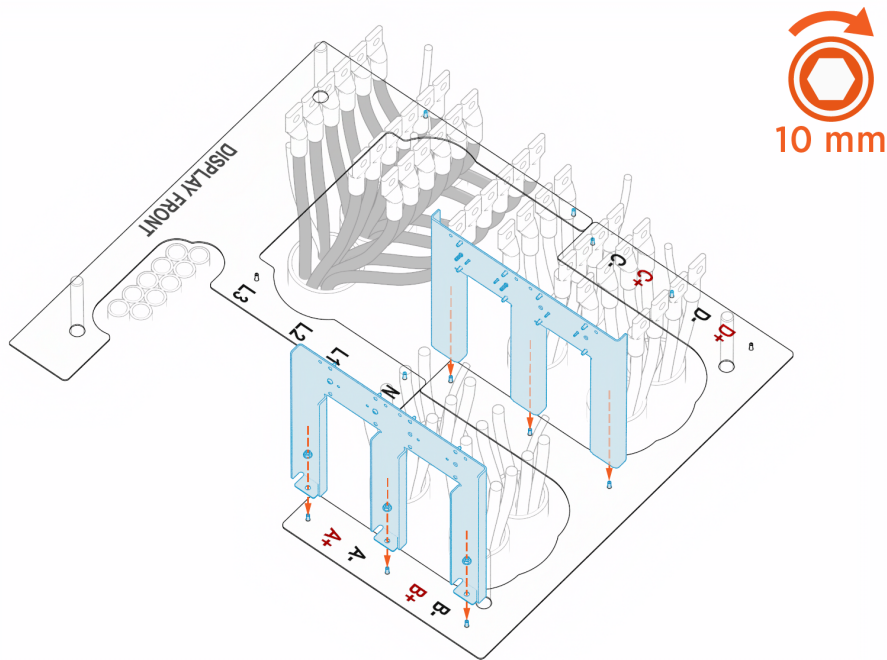

4. Use the stud landing bar to prepare the intake-side DC BUS positive (DC BUS +), DC BUS negative (DC BUS -), EXT B positive (B+), and EXT B negative (B-) wires, working one row at a time.



**NOTE:** DC BUS (intake side) wires are staged at the location marked 'A' on the jig alignment plate

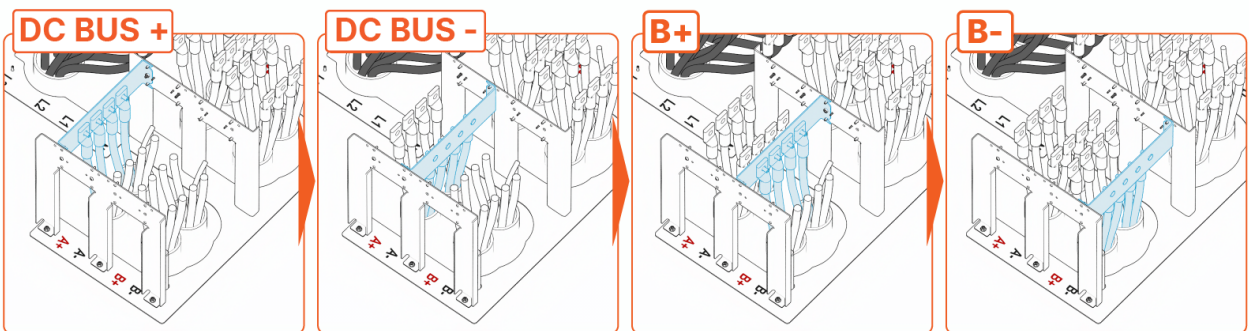

5. Remove the DC cable jig.

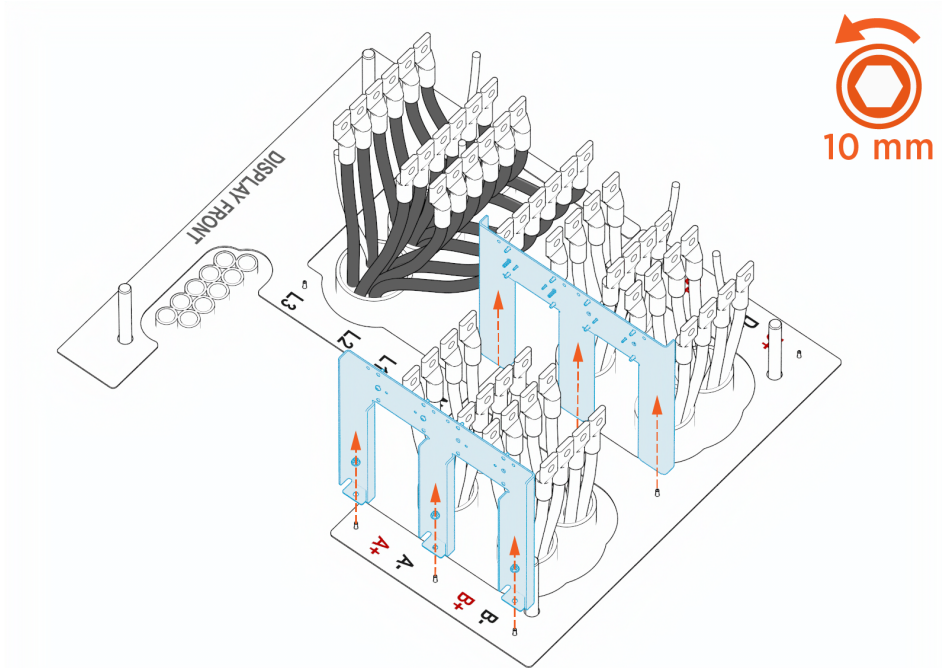

## Finalize Wire Preparation

1. Remove the jig alignment plates. First lift each jig alignment plate off the anchor bolts and then pull the plate away from the plate split line.

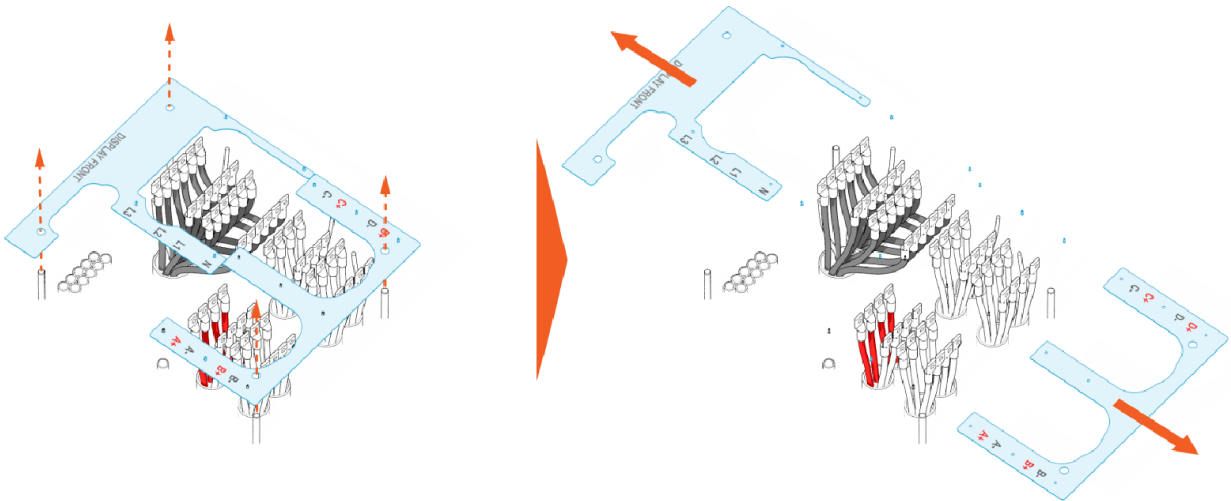

2. At each wire lug, apply dielectric grease to the back of the tongue.

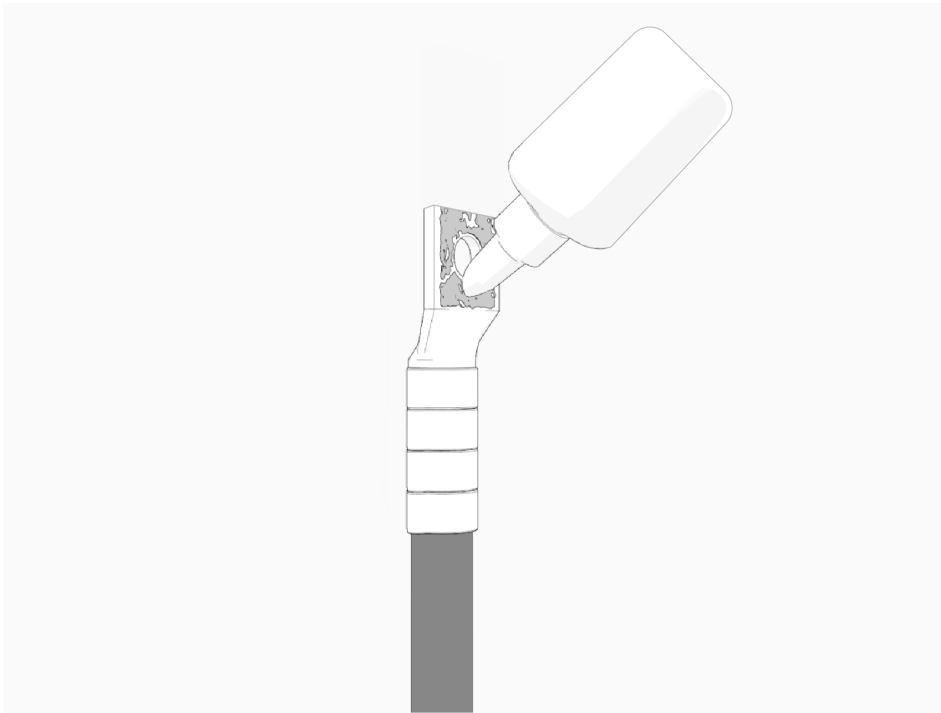

3. Use cling film to carefully bundle the wires as shown below. The ground/PE wires may be gathered within the wire bundles.

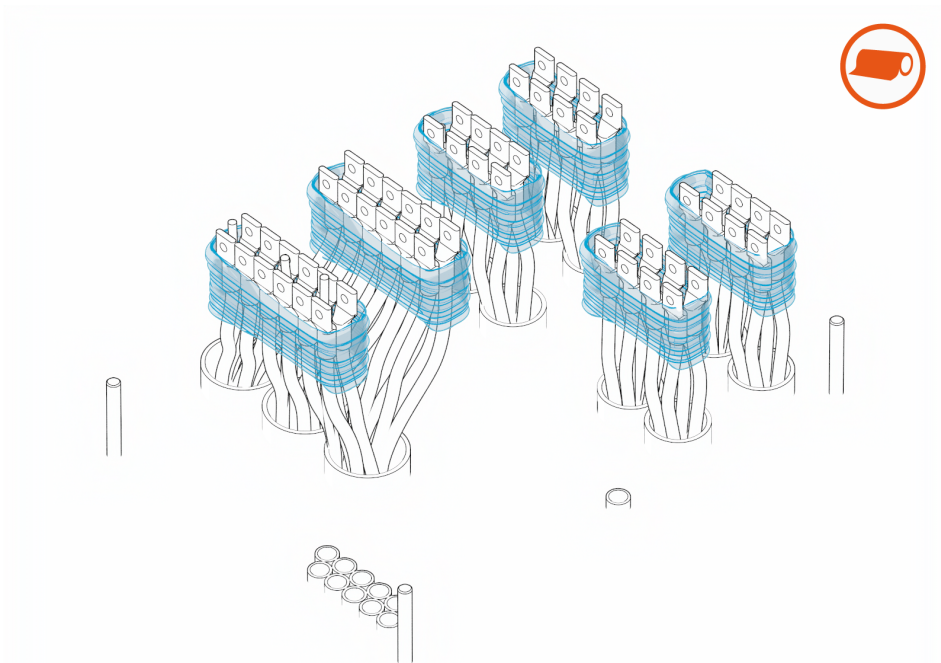

## Open Doors and Remove Safety Covers

Follow steps below to open the intake and exhaust doors and remove bus bar safety covers.

1. Use the door key to unlock the intake (right side) door. Swing the exhaust door open until the door stopper holds the door in open position.

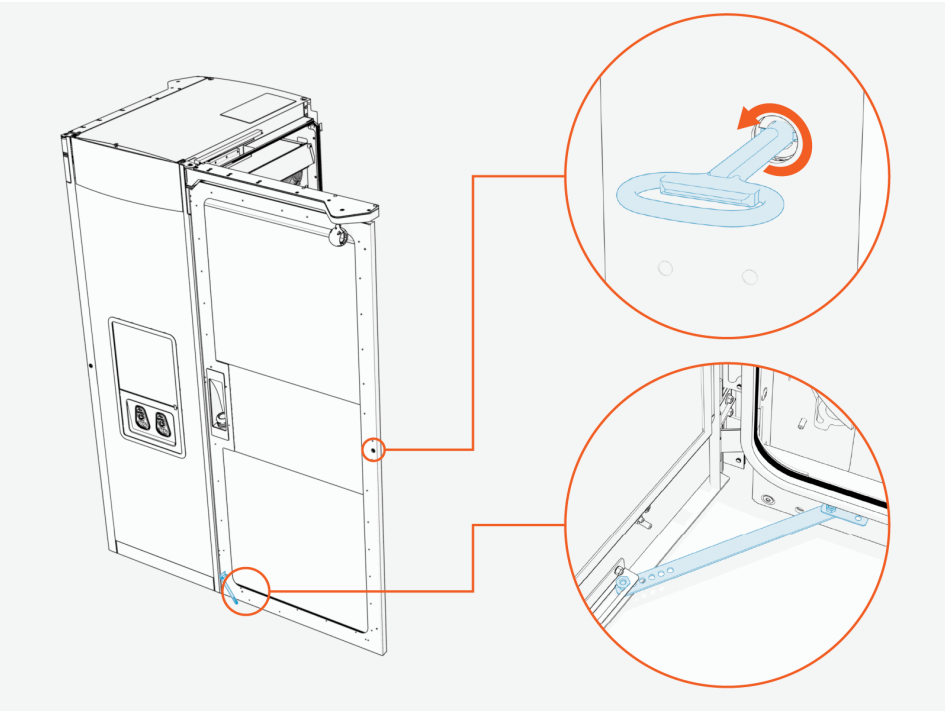

2. Open the exhaust (left side) door in the same manner. Make sure the door stopper holds the door in open position.

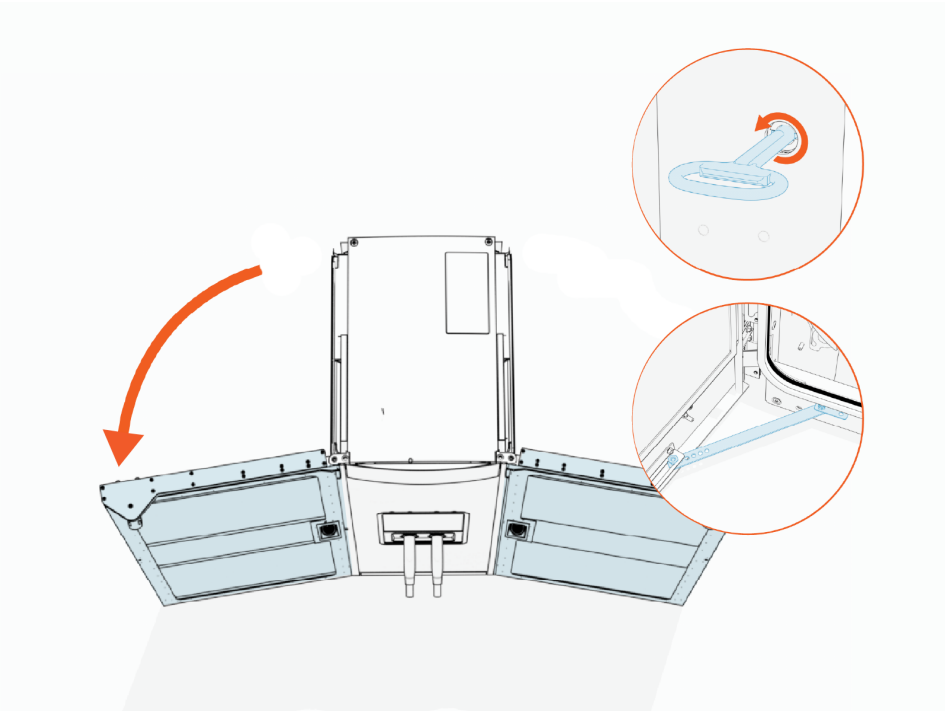

3. On the intake (right) side of the cabinet, loosen (do not remove) the nuts that secure the DC bus bars safety cover.

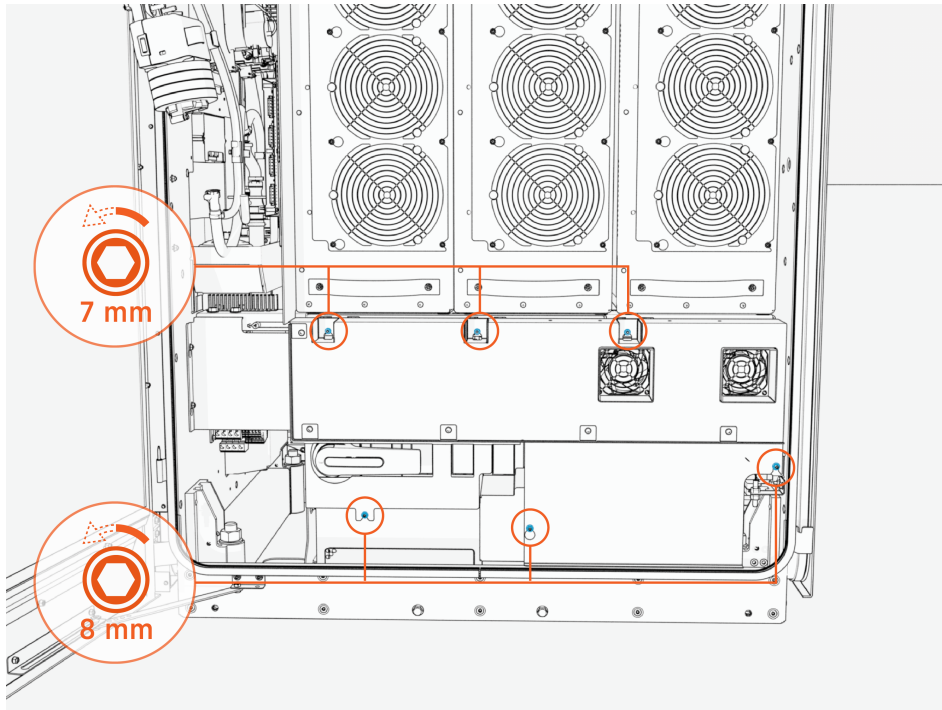

4. Slide the cover upward to release the keyholes. Then pull outward to remove the safety cover.

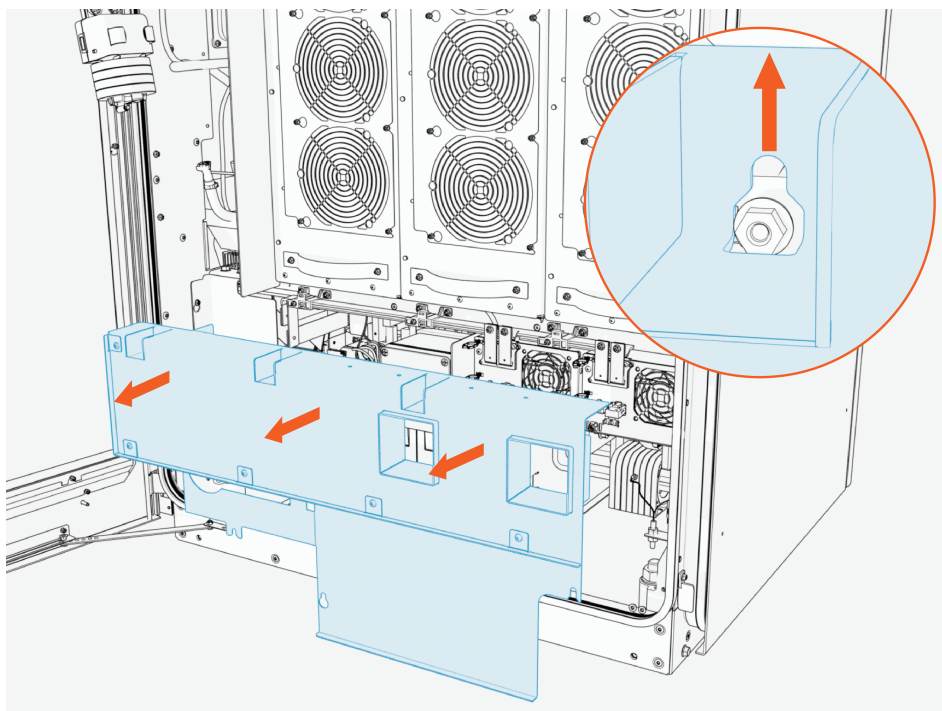

5. On the exhaust (left) side of the cabinet, loosen (do not remove) the nuts (x5) that secure the DC bus bar safety cover.

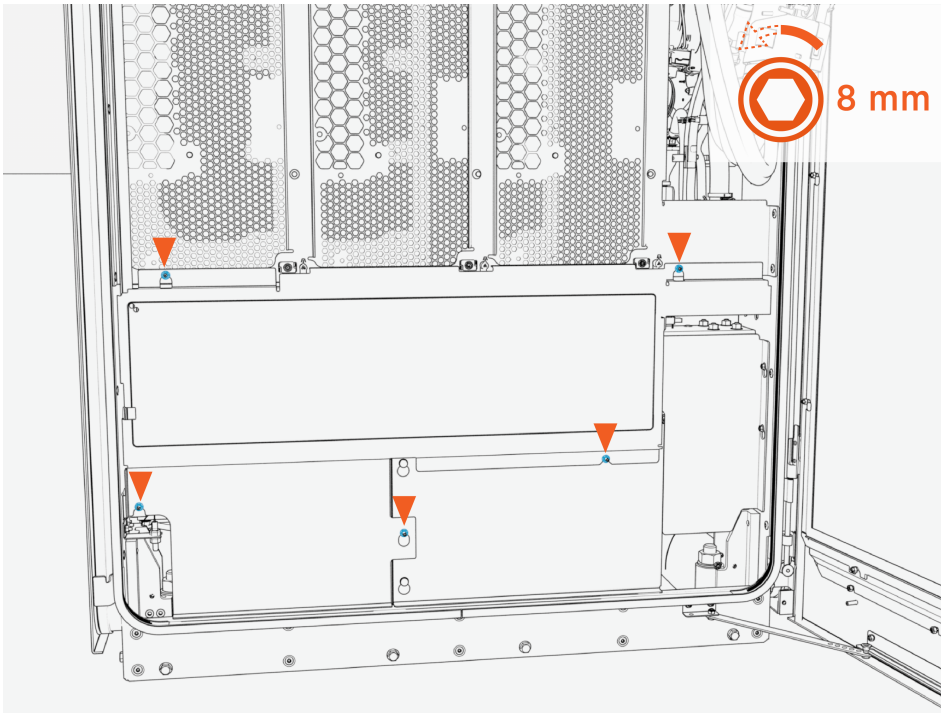

6. Slide the cover upward to release the keyholes. Then pull outward to remove the safety cover.

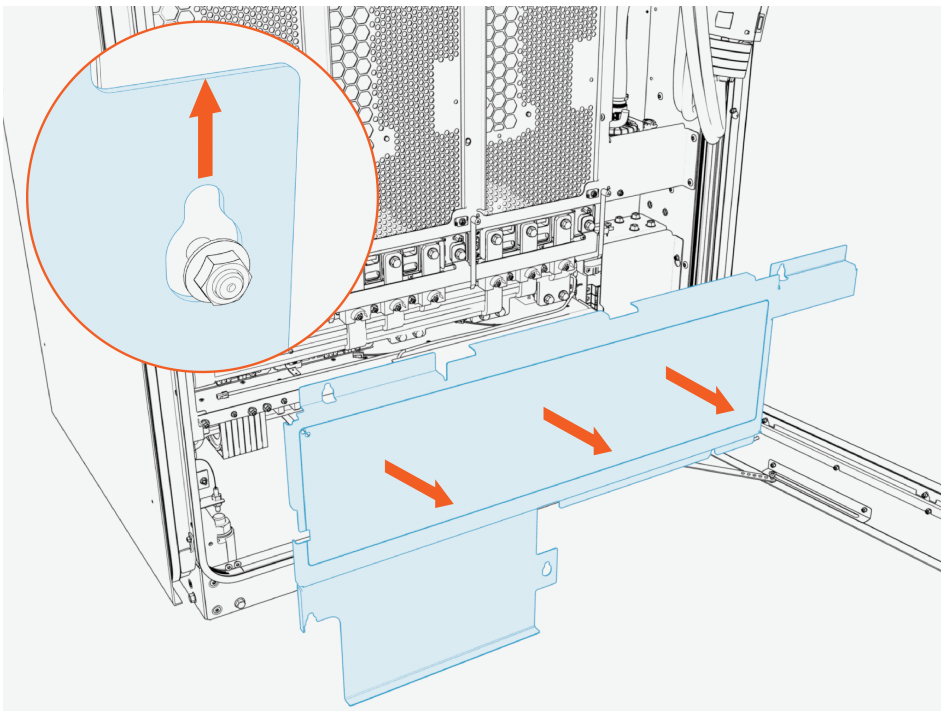

7. On the exhaust (left) side of the cabinet, loosen (do not remove) the nuts (x2) that secure the AC bus bars safety cover.

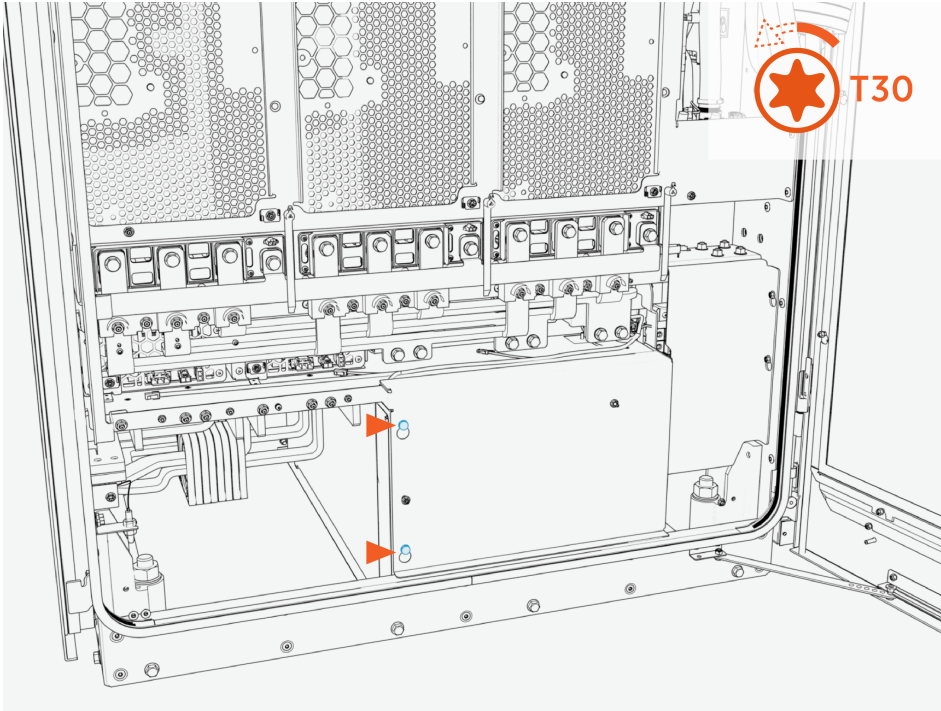

8. Slide the cover upward to release the keyholes. Then pull outward to remove the safety cover.

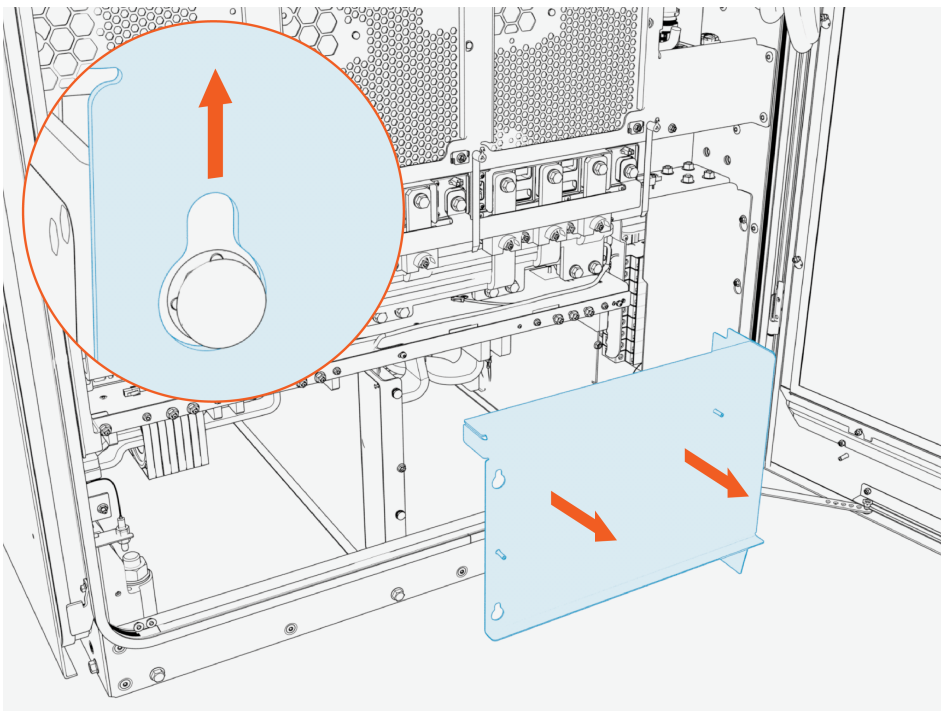

- 9. On the exhaust (left) side of the cabinet, loosen (do not remove) the nuts (x2) that secure the fuse block safety cover.

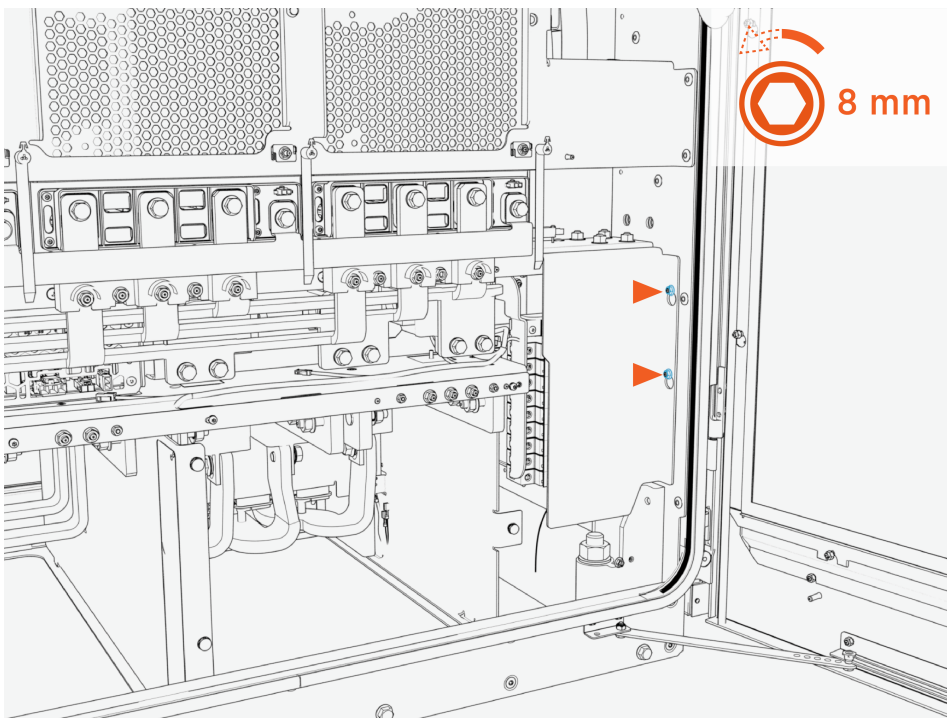

- 10. Slide the cover up to release the keyholes. Then pull outward to remove the safety cover.

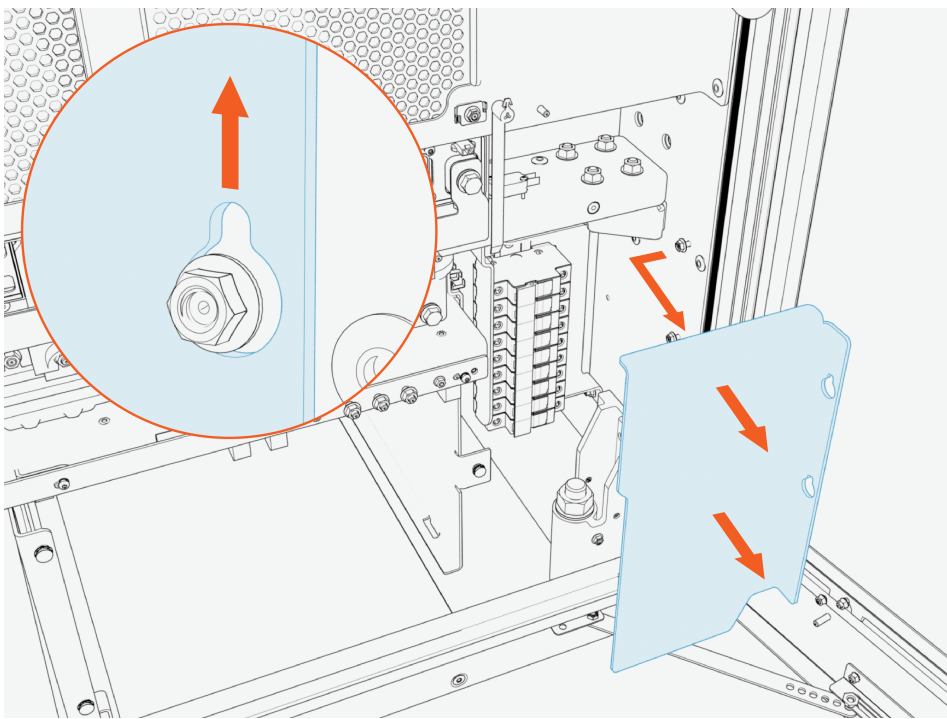

11. Disengage the door stays and close (do not lock) the intake and exhaust doors.

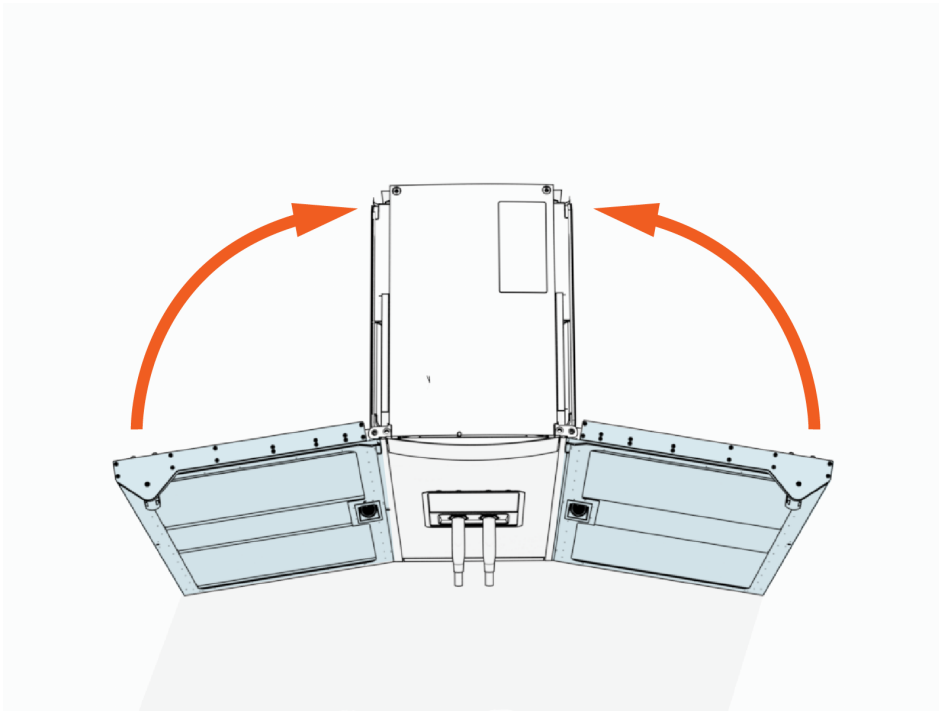

## Connect Charging Cables to Cable Management System

If Express Solo shipped configured with a swingarm CMK or fixed tether points for charging cables, you may opt to connect the cables to the cable management system prior to mounting Express Solo. Follow steps below to connect charging cables.

1. Install the charging cable tetherballs. See [Install Charging Cable Tetherballs](#).
2. Suspend the charging cables. See [Suspend Charging Cables](#).

## Lift Assembly

To install Express Solo, the assembly must be lifted from the shipping pallet. There two methods for lifting Express Solo:

- Standard Eye Bolt Lift: Lift the Express Solo assembly using eye bolts installed at the top of the assembly. This is the most common lift method.
- Forklift Bracket Lift: If installing Express Solo at a site with low clearance, the assembly may be lifted using forklift brackets installed at the sides of the assembly.

Follow instructions here to lift Express Solo using the standard method. If installing at a low-clearance site, see [Appendix: Low Clearance Forklift Bracket Lift](#).

1. Install eye bolts with rubber washers (x4 each). Torque to **2 Nm (18 in-lb)** minimum.

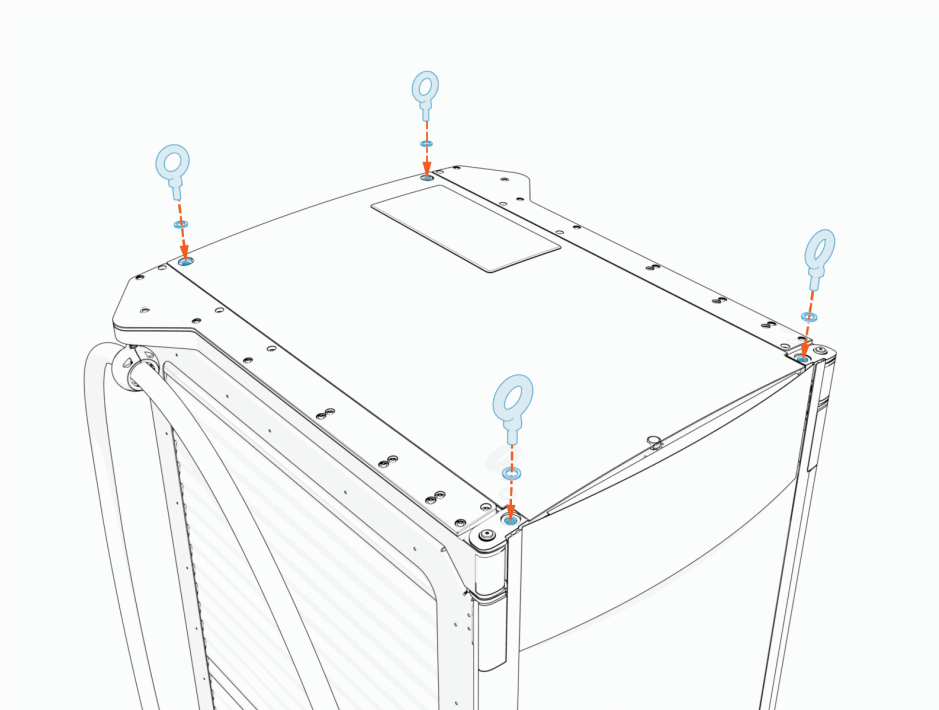

2. Thread lifting straps (x2) through eye bolts and install strap loops to hoisting equipment. Keep the straps slightly slack. Install a clamp on the end of the forklift tines to ensure lifting straps do not slip off tines.

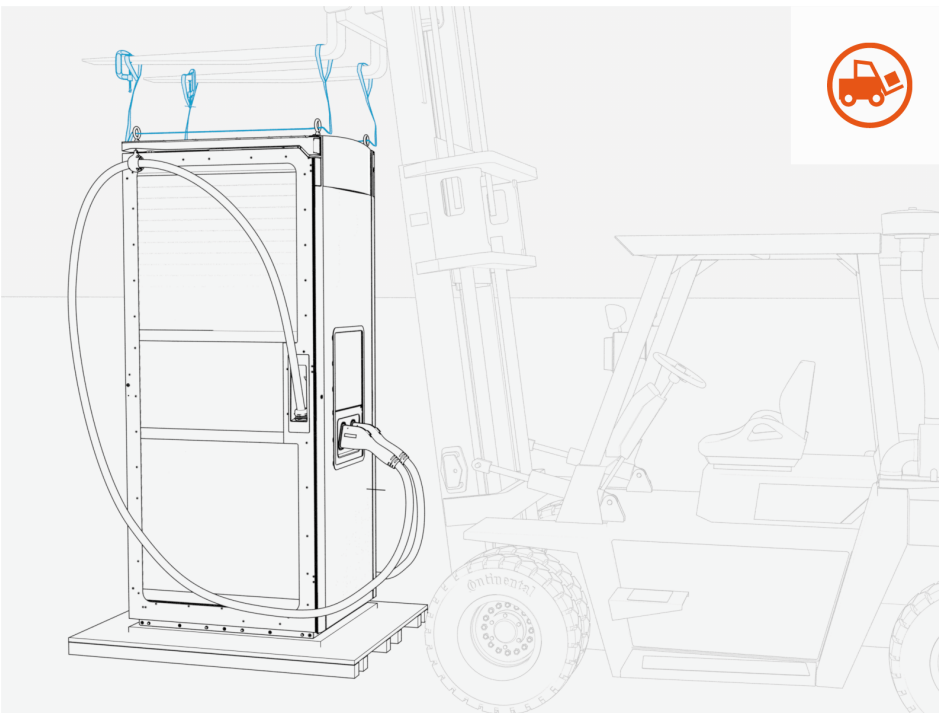

3. Open the intake door and locate two pallet bolts, one at each corner of the enclosure. Remove washer and nut from each pallet bolt.

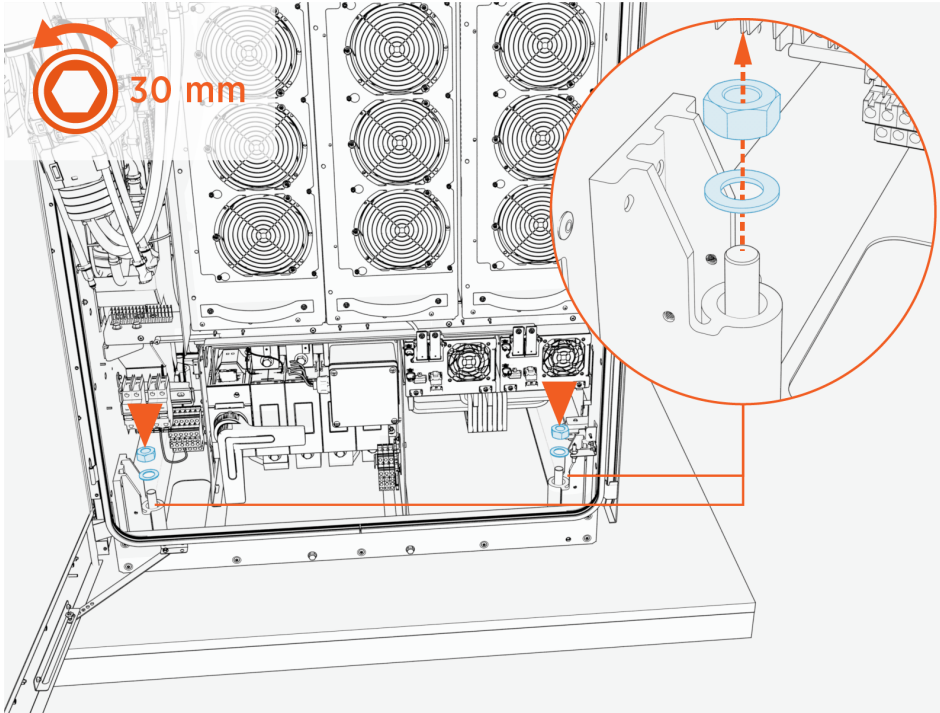

4. Open the exhaust door and locate two pallet bolts, one at each corner of the enclosure. Remove washer and nut from each pallet bolt.

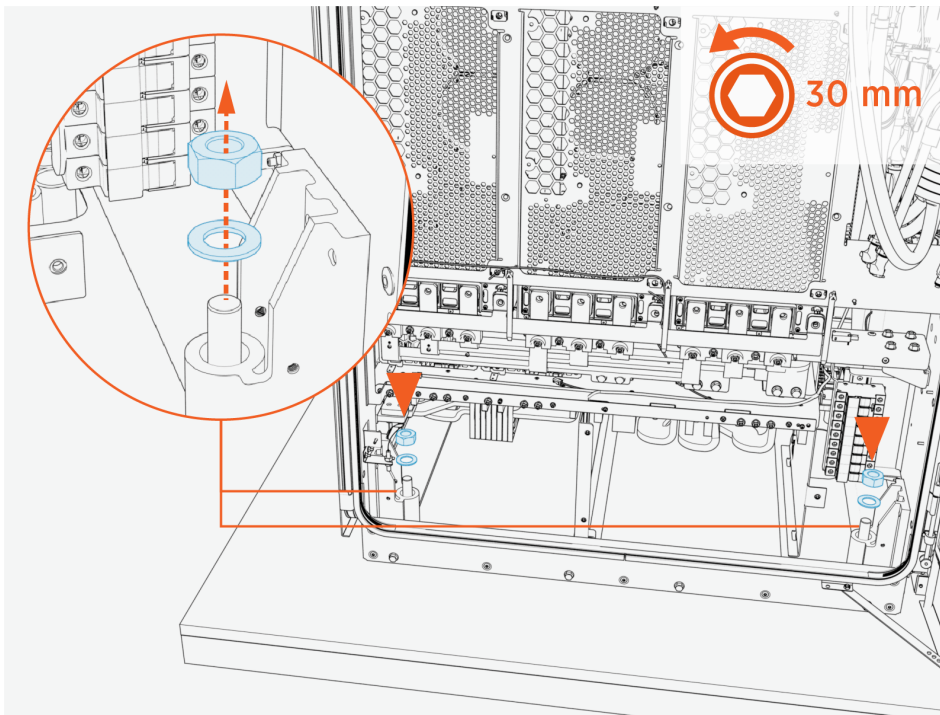

5. Close (but do not lock) the intake and exhaust doors and lift the assembly from the pallet.

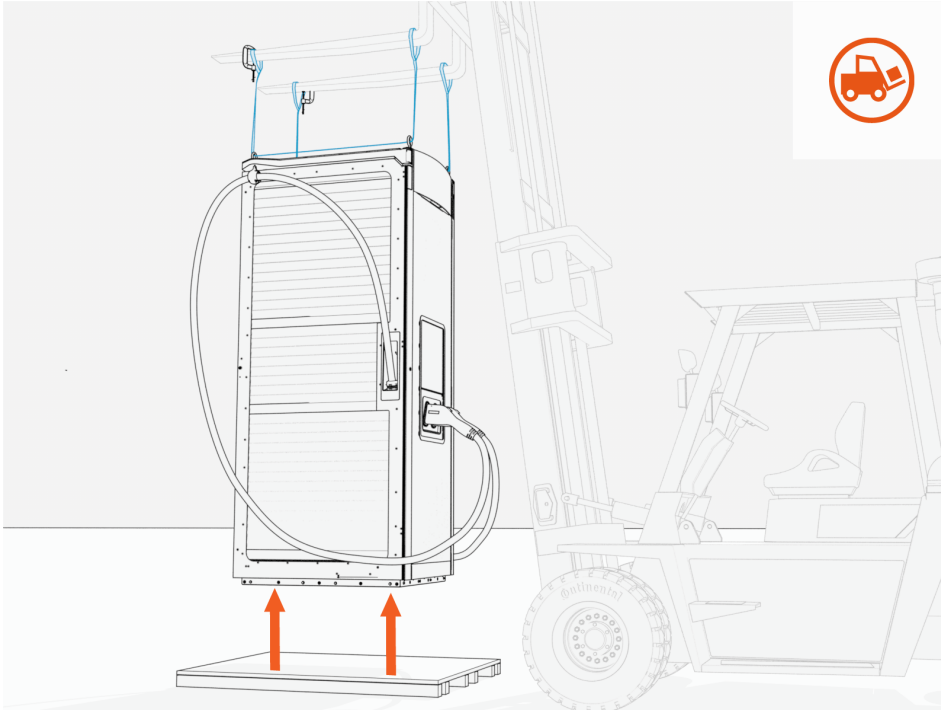

## Mount Assembly

Follow steps below to mount the Express Solo assembly. Illustrations depict the mounting procedure when using a forklift and lifting straps to mount the assembly. But the same concept at each step also applies when mounting the enclosure by forklift brackets.

1. Position the assembly over the anchor bolts and prepared cables.



**NOTE:** Open the intake and exhaust doors when the assembly is near to the ground, to prepare for alignment of the assembly to the anchor bolts. Make sure the door stays are engaged, holding the doors open.

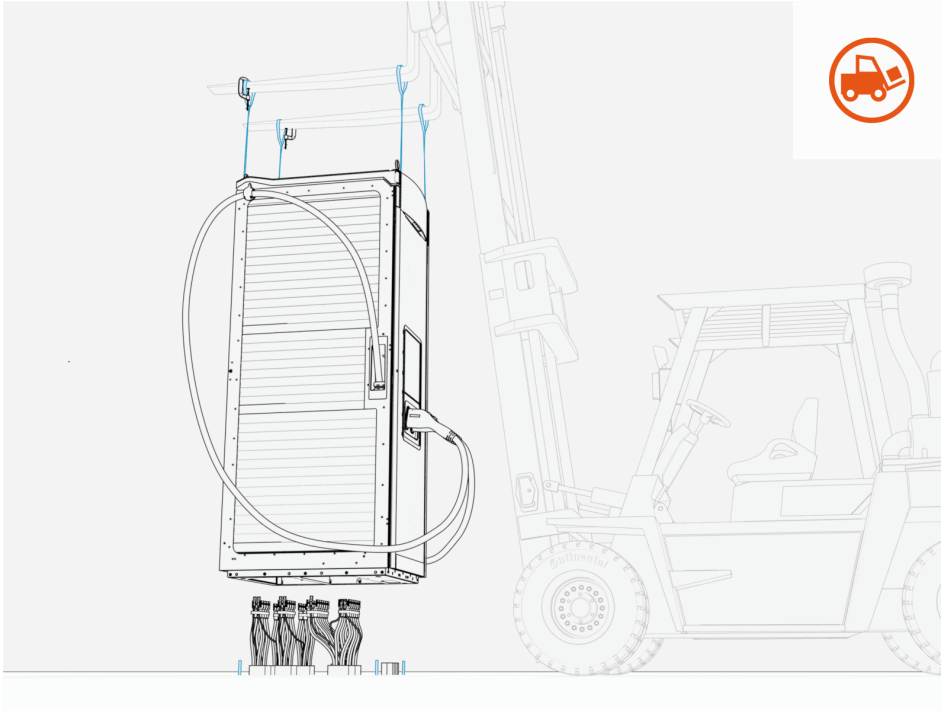

- Carefully align and lower the assembly over the anchor bolts (x4) and completely onto the ground.



**CAUTION:** Make sure the AC input, external DC output, and DC BUS cables are not disturbed as the assembly is lowered. The cables ends must align to the AC and DC bus bars within the assembly.



**WARNING:** Risk of pinching or crushing of body parts. Keep all body parts clear when lowering the assembly to the ground.

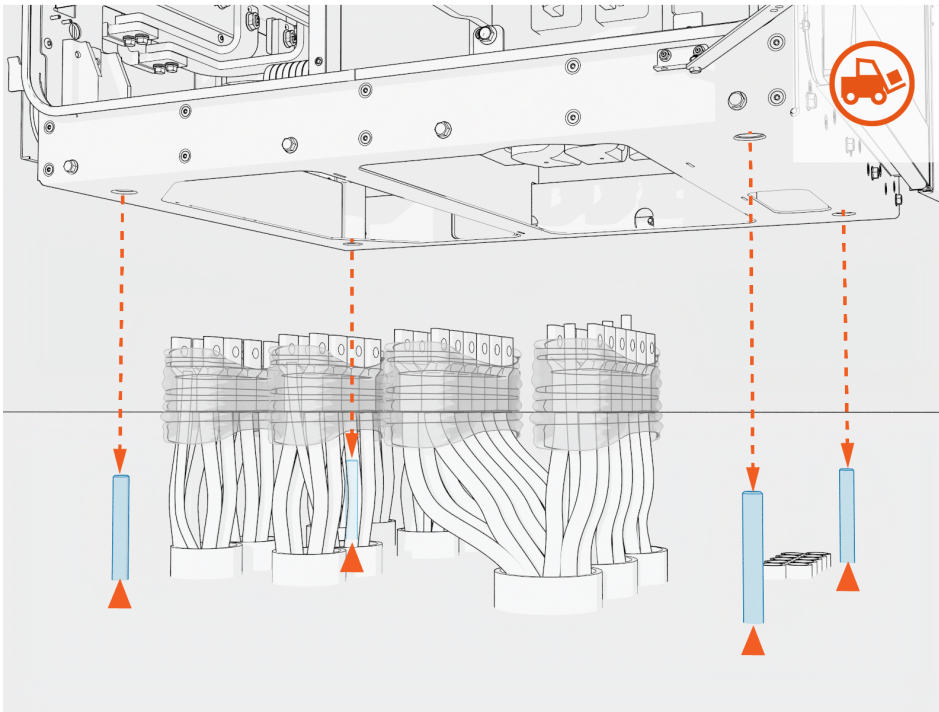

- Check that the assembly is level and plumb.

4. On the intake side of the enclosure, install an M20 washer and nut onto each anchor bolt. Torque to **136 Nm (100 ft-lb)**.

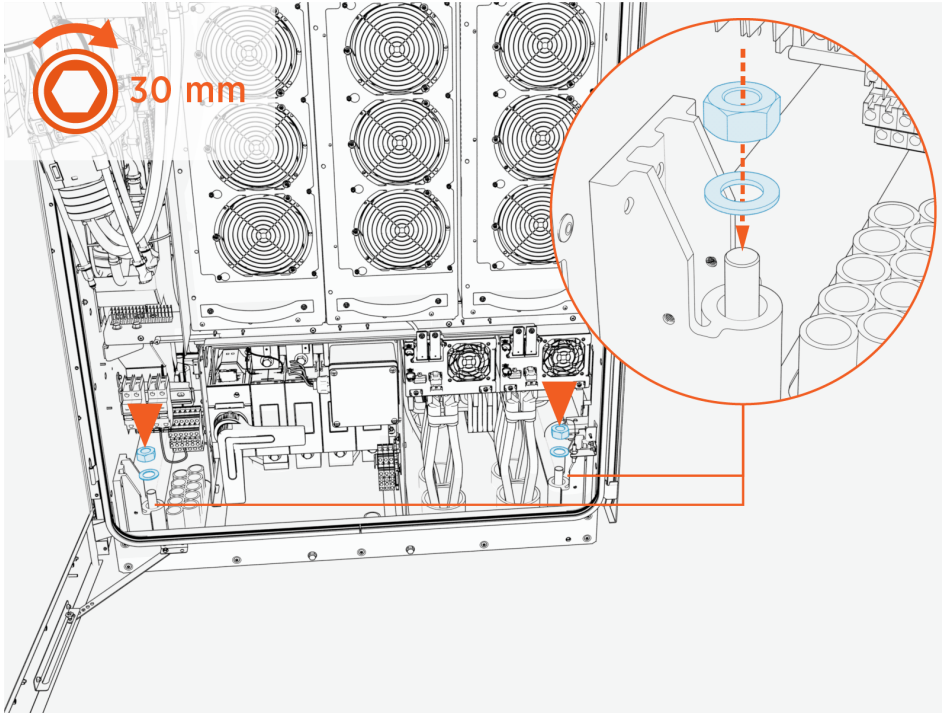

5. On the exhaust side of the enclosure, install an M20 washer and nut onto each anchor bolt. Torque to **136 Nm (100 ft-lb)**.

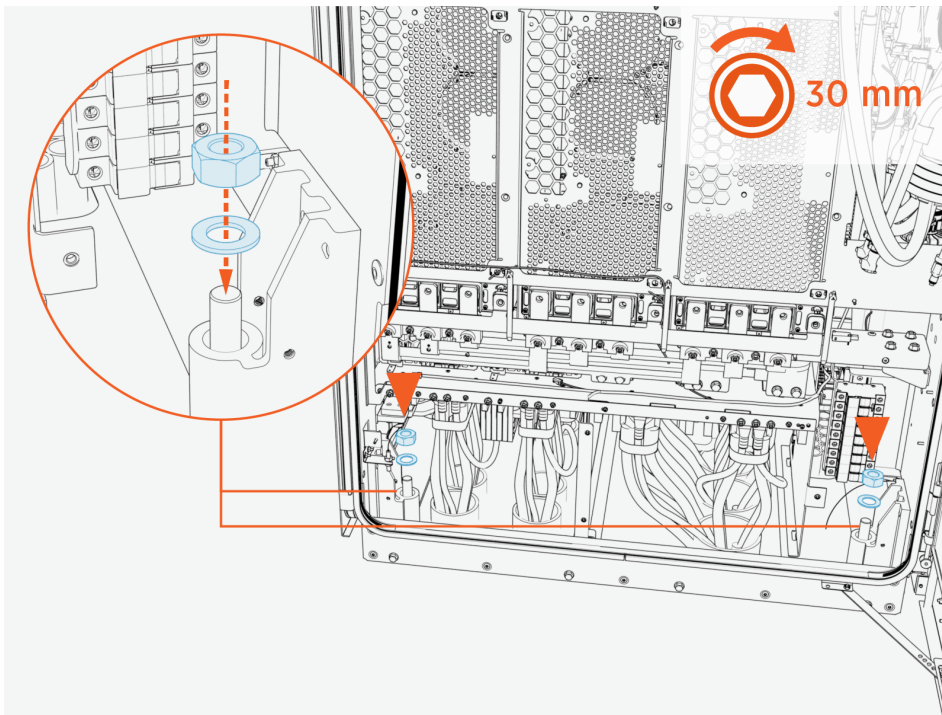

6. If the assembly was lifted using eye bolts, remove lifting straps, eye bolts, and eye bolt washers.

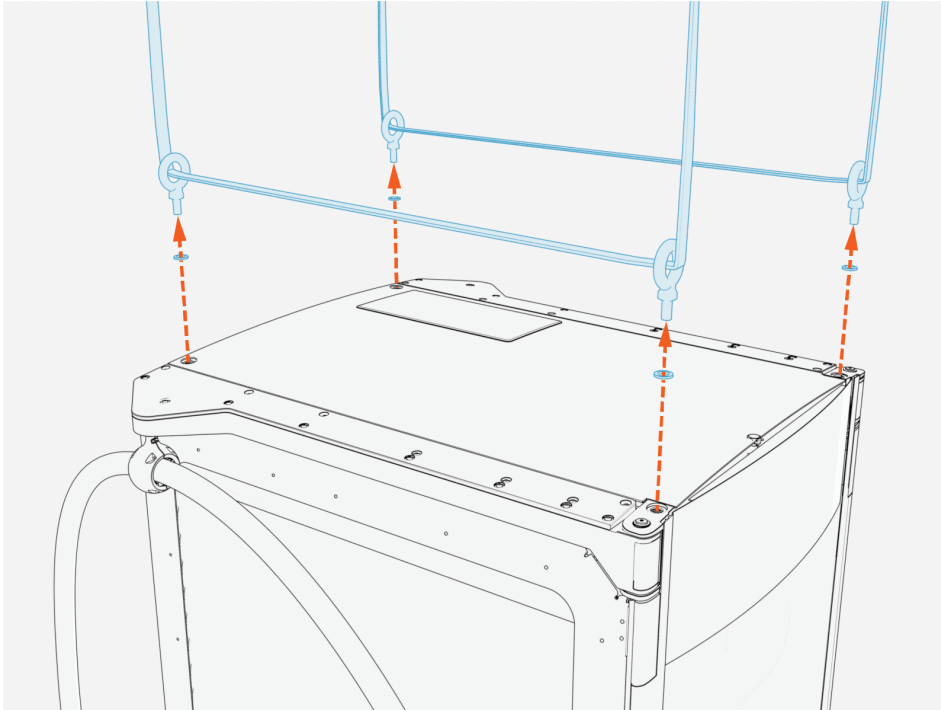

7. If the assembly was lifted using forklift brackets, remove the forklift brackets by reversing steps used to install the forklift brackets.

# Connect Wires 4

Follow all instructions provided in this section to connect wires.



**NOTE:** This section contains images depicting wires and conduits. The size and quantity of conduits and wires shown are for illustrative purposes only. The actual quantity and size of conduits and wires for your specific site may vary and shall depend on site specific requirements.

## Wire Terminal and Bus Bar Locations

Familiarize yourself with the wire terminal and bus bar locations illustrated below.

## Intake Side

The following identifies the wire terminals and bus bars accessible from the intake side (right side) of Express Solo. (Safety shields are hidden from view.)

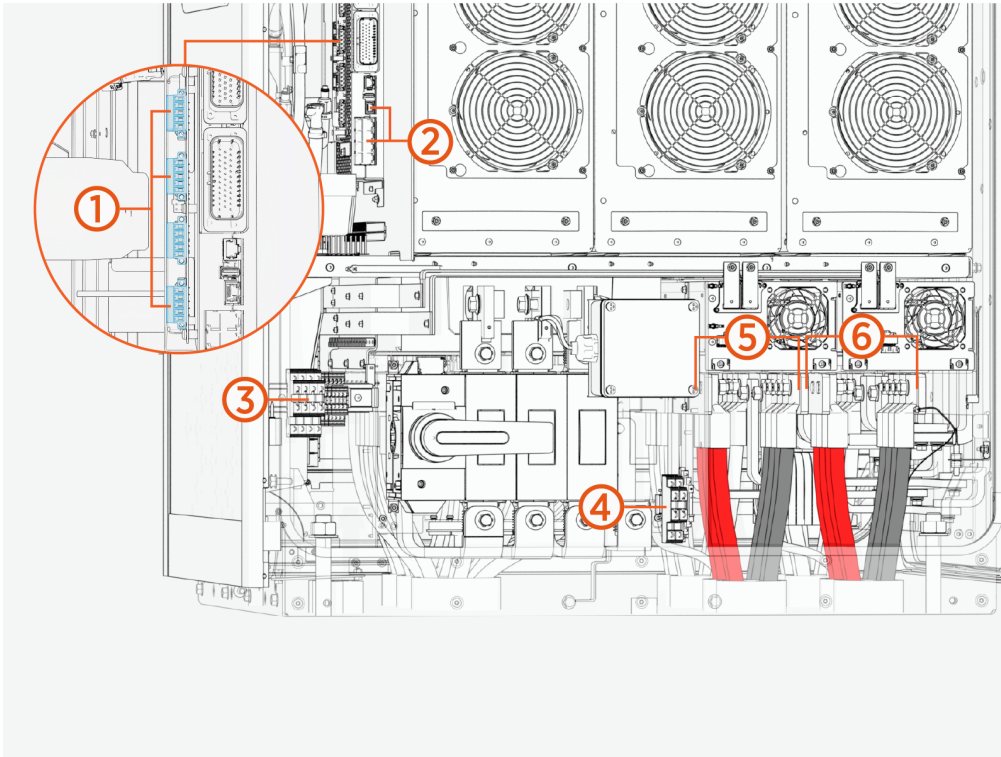

Ref	Part
(1)	Safety Hub ports
(2)	Ethernet ports
(3)	DC terminal block for 48 V DC, soft shutdown switch, door interlock sensor wires
(4)	Shunt trip terminals
(5)	DC BUS (intake side) bus bars
(6)	EXT B bus bars

The DC wire terminal block allocations are given below:

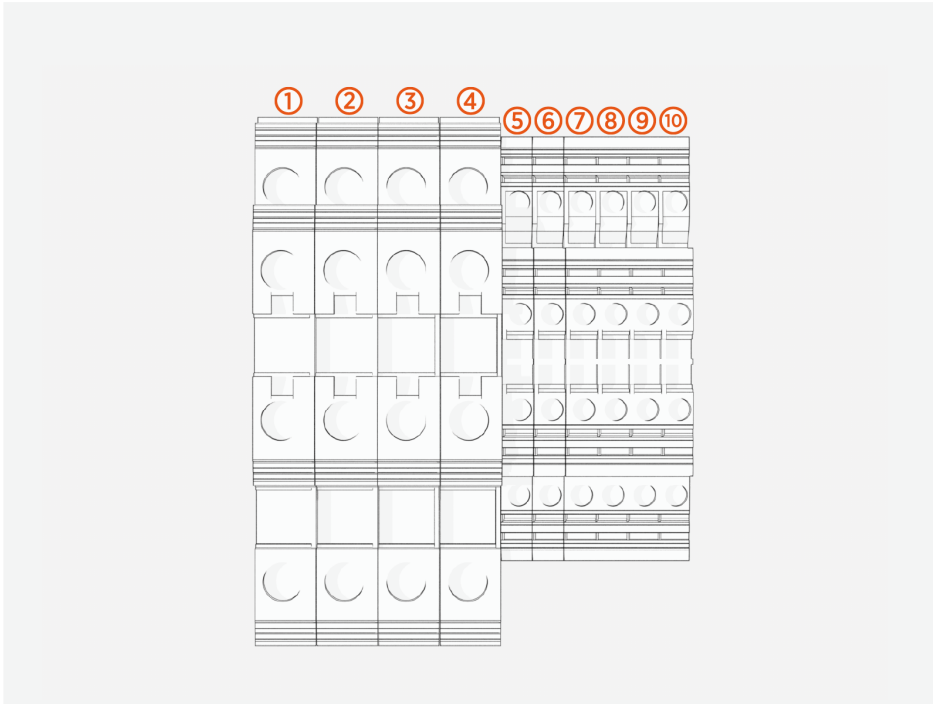

Ref	Allocation
(1)	48 V DC positive (+) to Power Link #1
(2)	48 V DC negative (-) to Power Link #1
(3)	48 V DC positive (+) to Power Link #2
(4)	48 V DC negative (-) to Power Link #2
(5)	Soft shutdown switch
(6)	Door interlock sensor
(7)	Not used for Express Solo
(8)	Not used for Express Solo
(9)	Not used for Express Solo
(10)	Not used for Express Solo

The shunt trip terminal allocations are given below:

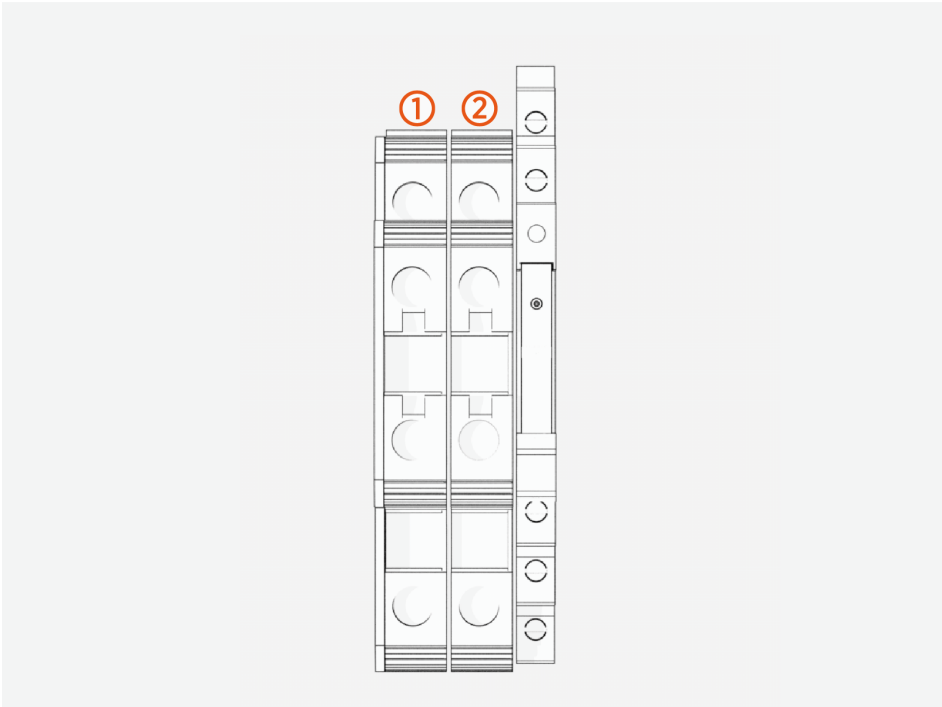

Ref	Allocation
(1)	Shunt 1
(2)	Shunt 2

## Exhaust side

The following identifies the wire terminals and bus bars accessible from the exhaust side (left side) of Express Solo. (Safety shields are hidden from view.)

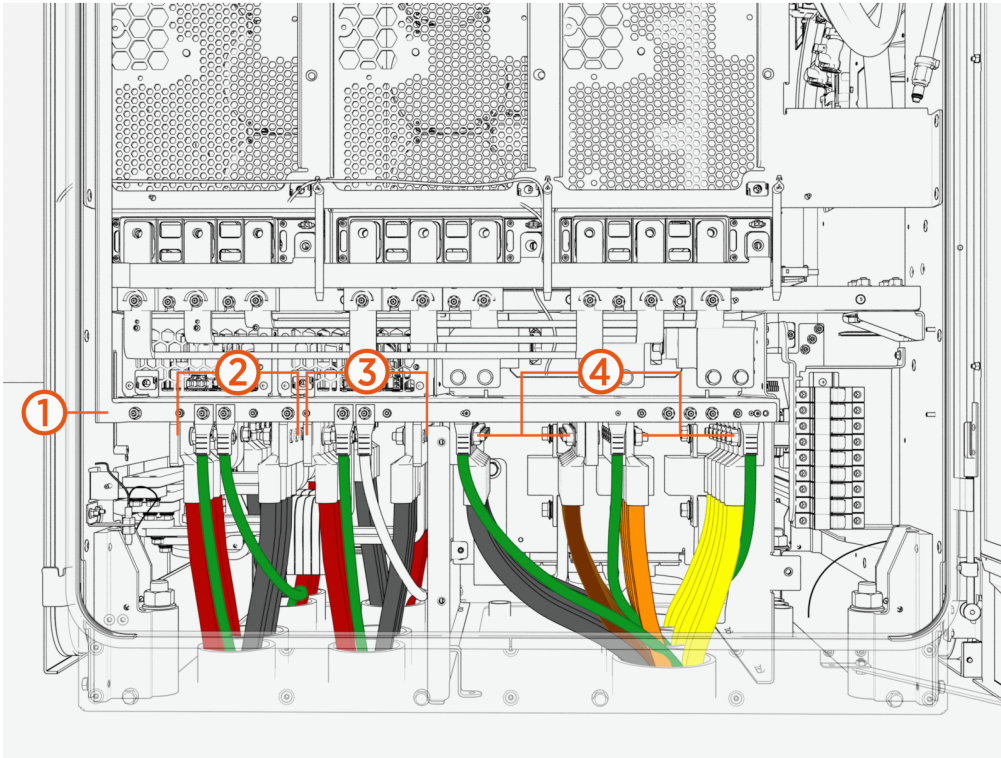

Ref	Part
(1)	PE/ground bar (with wire landing studs)
(2)	EXT D bus bars
(3)	DC BUS (exhaust side) bus bars
(4)	AC input (L1, L2, L3) and Neutral bus bars

# Unwrap Wires

Carefully remove cling film from the wires.



**CAUTION:** Use caution if using a sharp tool to cut the cling film. Do not damage the wires when removing the cling film.

## Connect AC Input Wires

Follow steps below to connect the AC input wires.

1. Use the [wire landings diagram](#) to locate the AC input wire bus bars. The bus bars are accessible on the exhaust side (left side) of Express Solo.
2. Install each AC input wire onto a wire landing stud with provided M10 nut. Torque nut to **19 Nm (14 ft-lb)**.



**NOTE:** Start at the inner-most landing and work your way out.

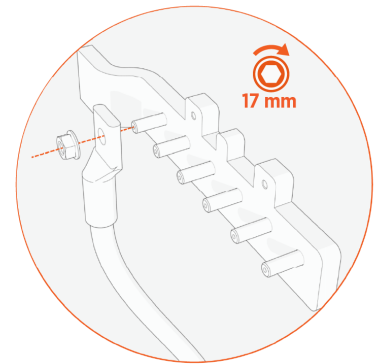
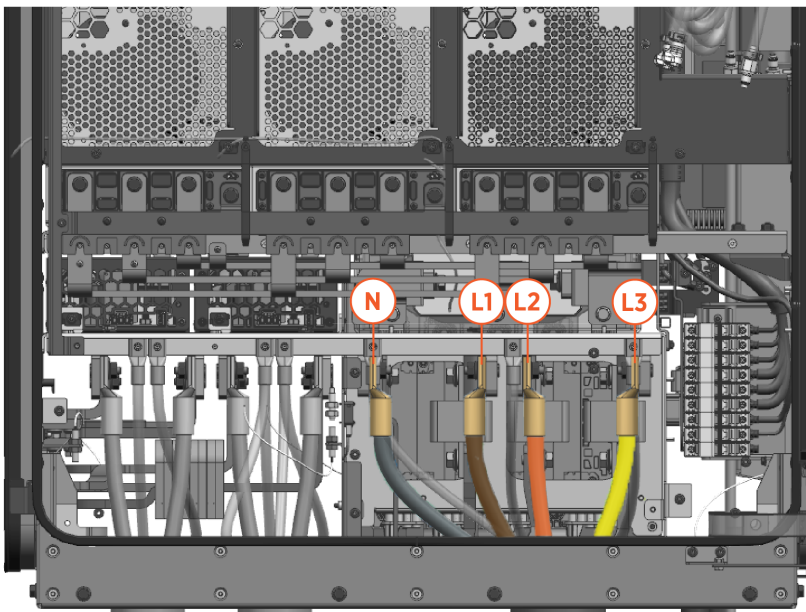

3. Apply torque marks to all torqued connections.

## Connect AC Protective Earth (PE) Wires

Follow steps below to connect the AC input PE wires.

1. Use the [wire landings diagram](#) to locate the PE landing studs. The studs are accessible on the exhaust side (left side) of Express Solo.
2. Temporarily install the AC input PE wire lugs onto the ground bar using provided M6 nuts. Use a 10 mm socket to hand-tighten.
3. Measure and cut the PE wires to length.

4. Remove the lugs from the ground bar.
5. Terminate each PE wire with a lug:
  - a. Mark the lug's barrel height on the cable.
  - b. Strip the wire jacket. Use a suitable wire stripper, such as a Klein tool.
  - c. If recommended by the wire manufacturer or local code, apply an anti-oxidant joint compound to the bare cable to make a gastight joint with the lug.
  - d. Insert the stripped wire end into the lug barrel and crimp it. Use a suitable lug crimping tool and/or die recommended by the lug manufacturer.
6. Install each PE wire onto a wire landing stud with provided M6 nut. Torque nut to **5.6 Nm (50 in-lb)**.

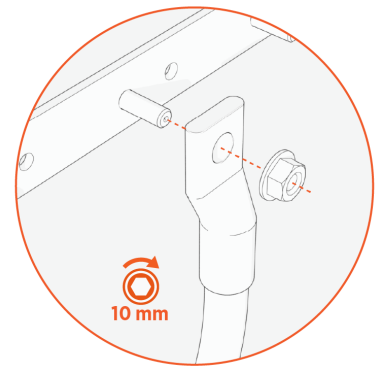
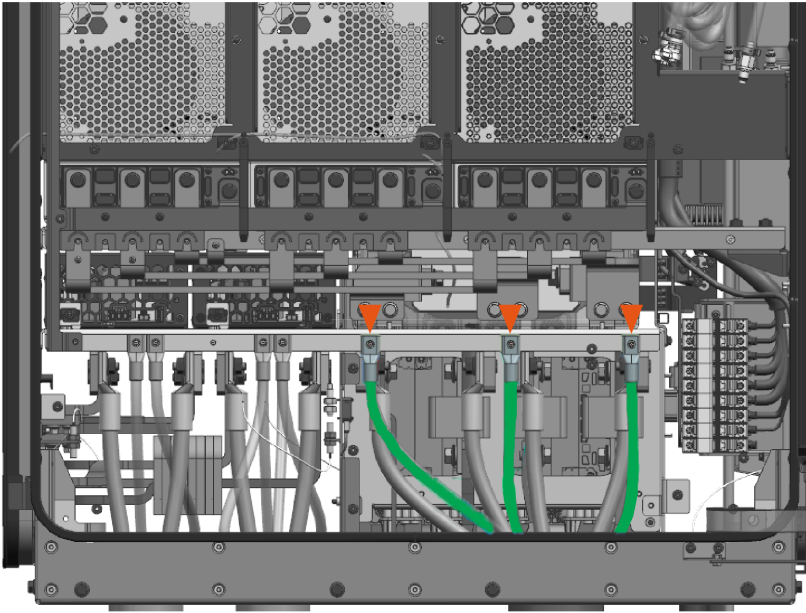

## Connect DC BUS Wires

Follow steps below to connect the DC BUS wires.

1. Use the [wire landings diagram](#) to locate the DC BUS wire bus bars. The bus bars are accessible on both the intake side (right side) and exhaust side (left side) of Express Solo.

2. Install each DC BUS wire onto a wire landing stud with provided M10 nut. Torque nut to **19 Nm (14 ft-lb)**.

The illustration below depicts wire installation on the exhaust side. Start at the inner-most landing and work your way out.

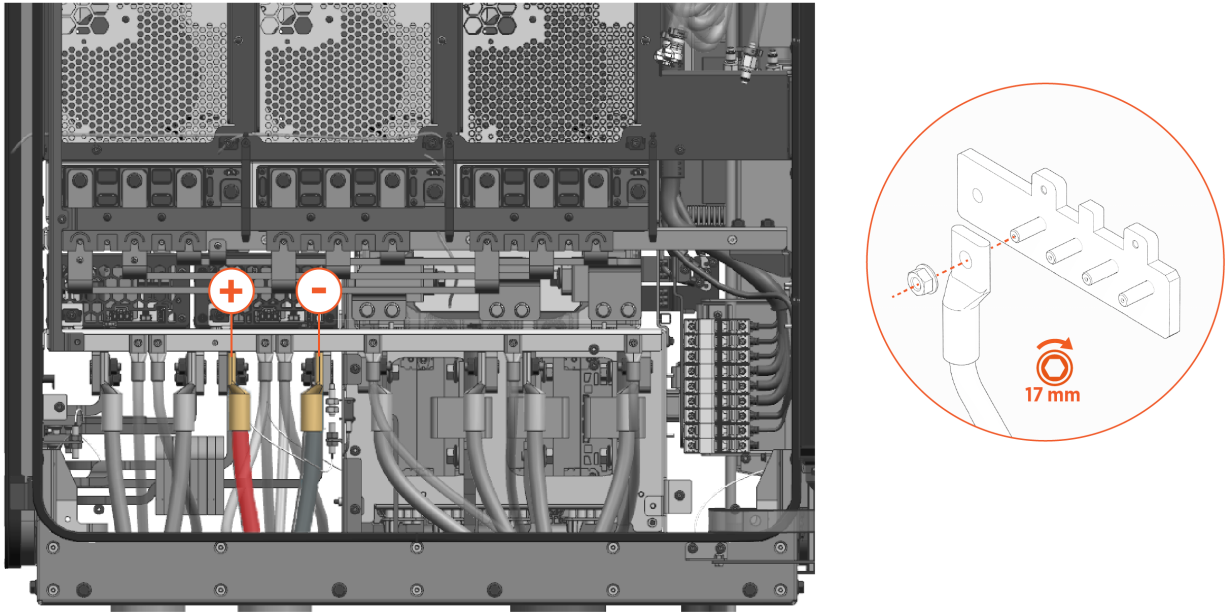

3. Apply torque marks to all torqued connections.

## Connect External DC Output Wires

Follow steps below to connect the external DC output (EXT B and EXT D) wires.

1. Use the [wire landings diagram](#) to locate the EXT B and EXT D wire bus bars. The bus bars are accessible on both the intake side (right side) and exhaust side (left side) of Express Solo.

2. Install each DC wire onto a wire landing stud with provided M10 nut. Torque nut to **19 Nm (14 ft-lb)**. The illustration below depicts EXT D wire installation on the exhaust side. Start at the inner-most landing and work your way out.

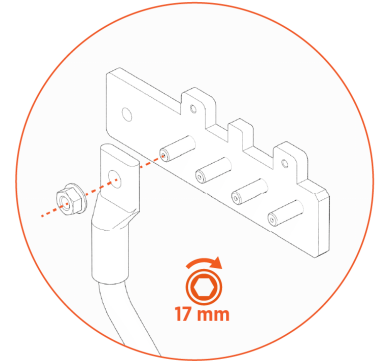
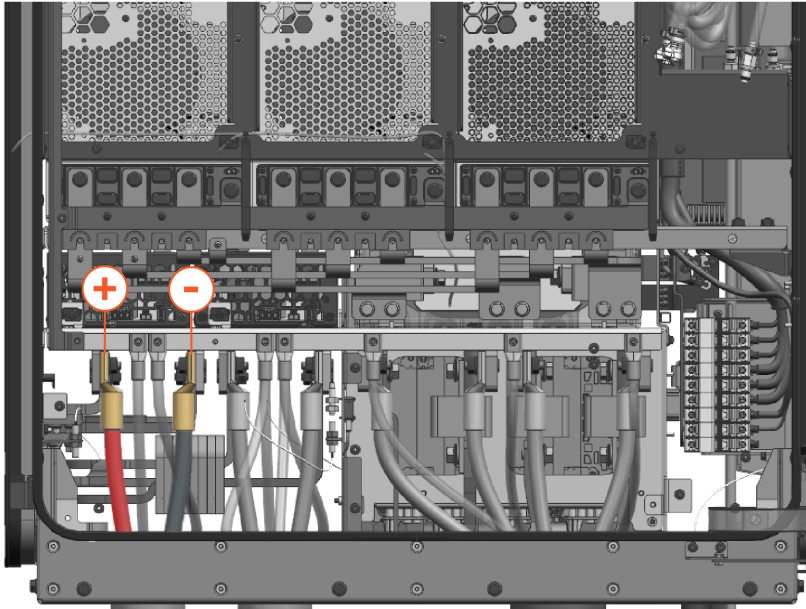

3. Apply torque marks to all torqued connections.

## Connect DC PE/Ground Wires

Follow steps below to connect the DC PE/ground wires.

1. Use the [wire landings diagram](#) to locate wire landing studs on the DC PE/ground bar. The ground bar is accessible on the exhaust side (left side) of Express Solo.

- Using same method used to install the AC input PE wires, install each DC PE/ground wire onto a wire landing stud with provided M6 nut. Torque nut to **5.6 Nm (50 in-lb)**.

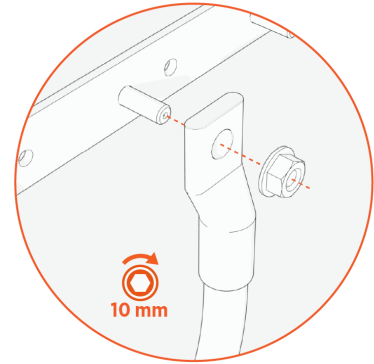

## Pull Remaining Wires

Pull remaining wires into the Express Solo enclosure. Depending on the site-specific system architecture, this may include one or more of the following:

- 48 V DC wires
- Ethernet cables
- Door interlock sensor wires
- Safety Hub wires
- Soft shutdown switch wires
- Shunt trip wires

To pull the wires:

1. Study the line diagram carefully to understand which wires should be pulled through each conduit.
2. Label all wires at both ends.
3. Pull the wires through conduit.

## Connect 48 V DC Wires

1. On the intake (right) side of the cabinet, loosen (do not remove) nuts (x2) that secure the DC terminals cover.

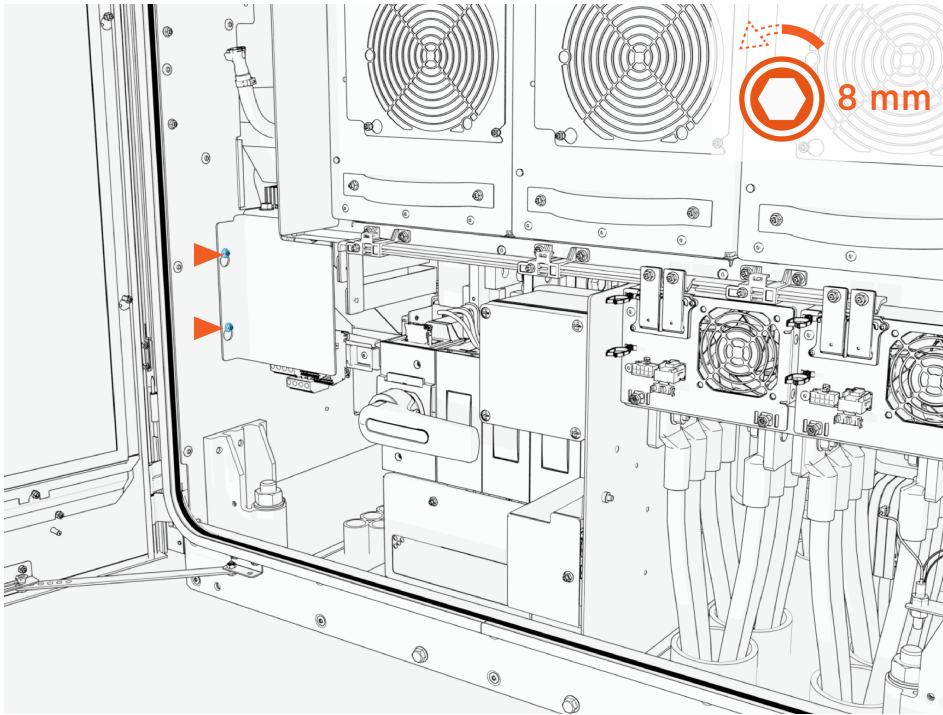

2. Slide the cover up to release the keyholes. Then pull outward to remove the safety cover.

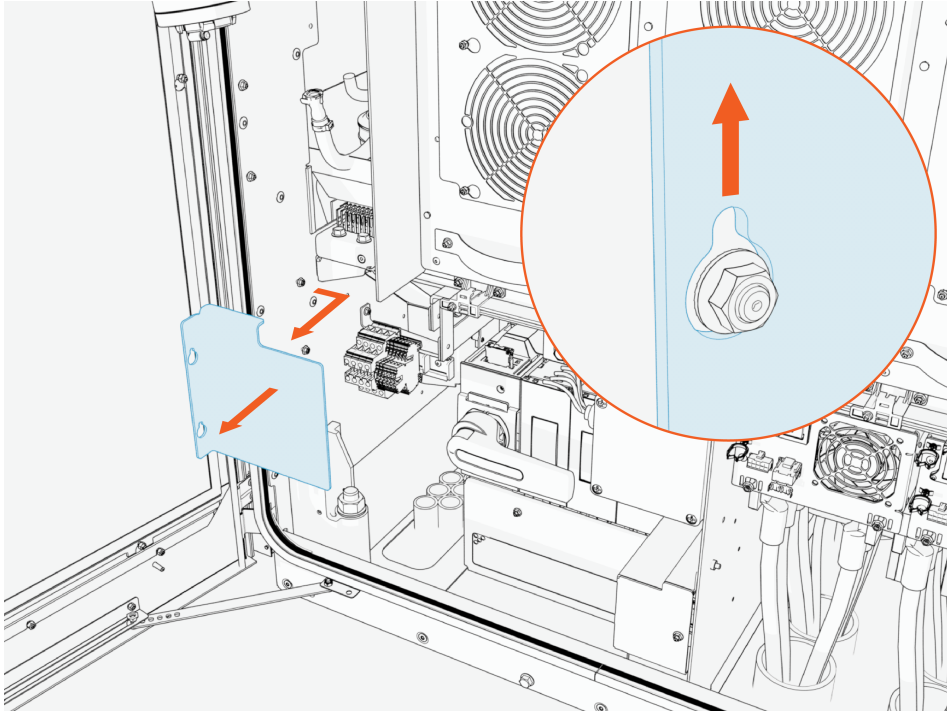

- Use the [wire landings diagram](#) to locate the 48 V DC terminals within the cabinet. The terminals are accessible on the intake side (right side) of Express Solo.

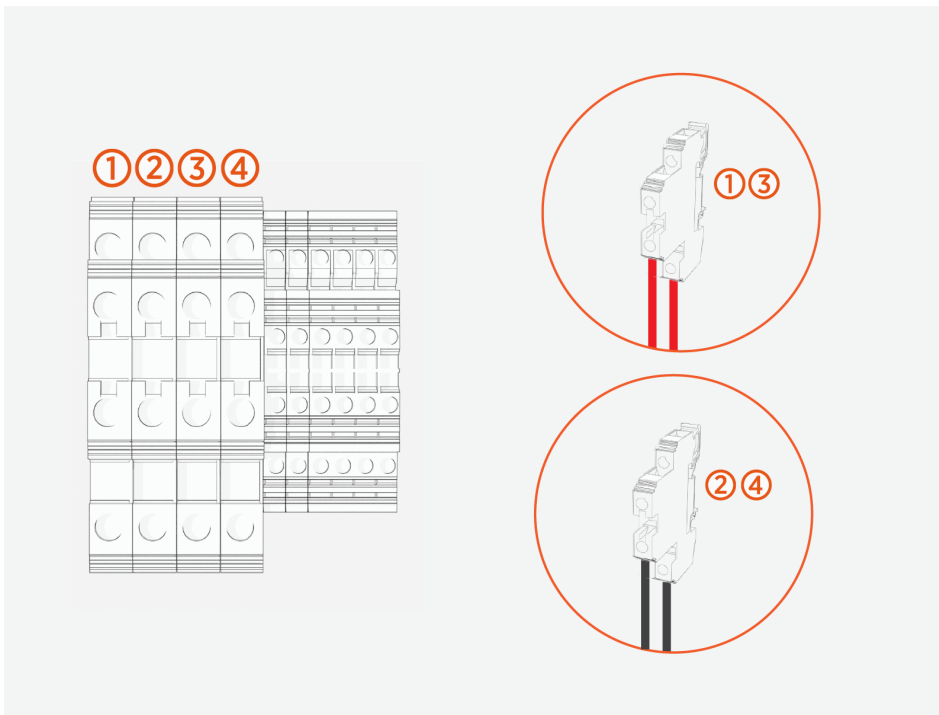

- (1) Positive (+) 48 V DC to Power Link #1
- (2) Negative (-) 48 V DC to Power Link #1
- (3) Positive (+) 48 V DC to Power Link #2
- (4) Negative (-) 48 V DC to Power Link #2

Each terminal has:

- An upper-level wire insertion point with a corresponding set screw
- A lower-level wire insertion point with a corresponding set screw

Within a single terminal, the two levels are interchangeable.

A minimum of *one* 48 V DC wire pair must be run between the Express Solo and each connected Power Link. If the distance between the Express Solo and the Power Link is greater than 100 m (328 ft), then *two* 48 V DC wire pairs must be run between the Express Solo and Power Link to maintain acceptable voltage levels.

- Route the 48 V DC wires through the wireway clamps up to the 48 V DC terminals. If necessary use cable ties to secure the wires.

5. Install the wires at each terminal with the following steps:
  - a. Cut the wire (or wires) to length for landing at the terminal.
  - b. Strip the wire jacket. If using a wire ferrule, install the ferrule after stripping the conductor.

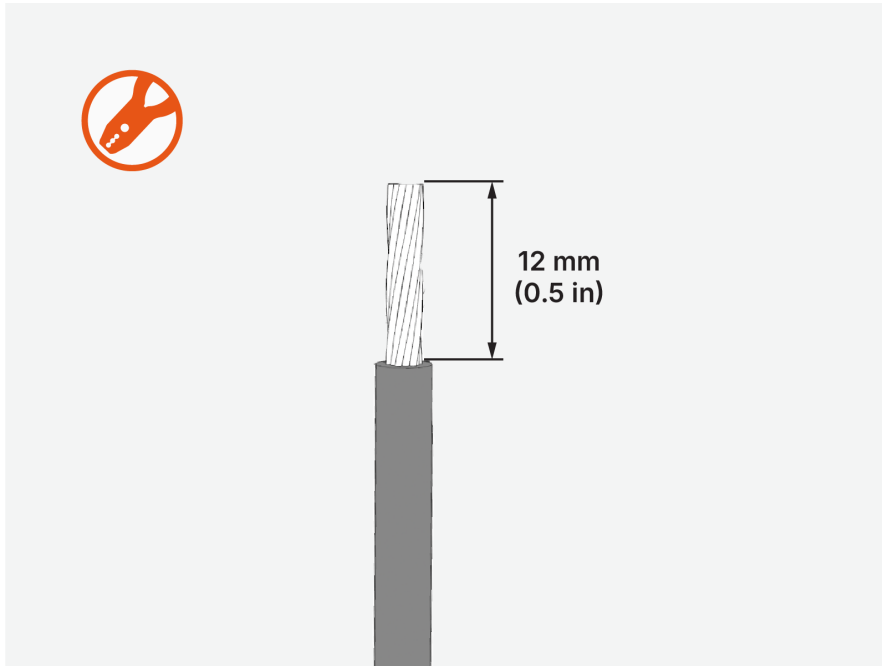

- c. On the terminal, loosen the set screw for each level where a wire will be inserted.

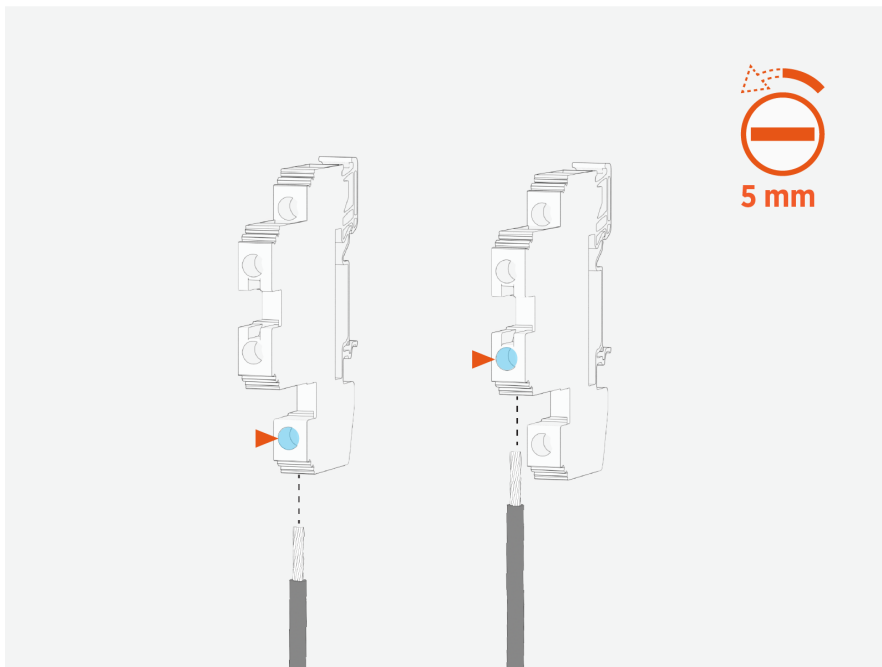

- d. Insert the wire (or wires) into the terminal. Torque the set screws (x2) to **2 Nm (18 in-lb)**.

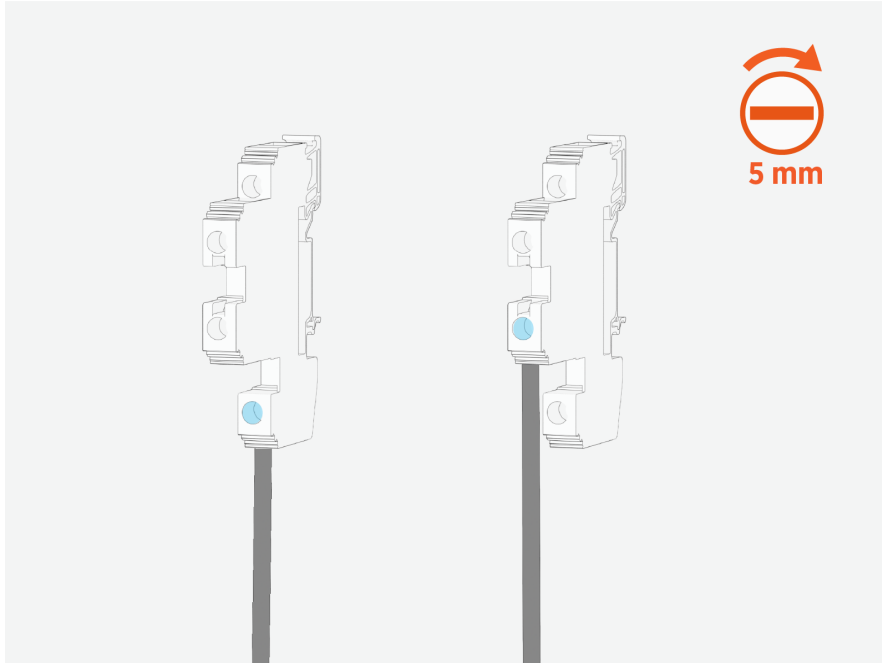

- e. Push-pull to test that all wires (+ and -) are firmly secured.

# Connect Ethernet Cables

Follow steps below to connect the Ethernet cables.

1. Use the [wire landings diagram](#) to locate and identify the Ethernet ports on the Power Management Controller (PMC) within the cabinet. The PMC is accessible from the intake side (right side) of Express Solo.

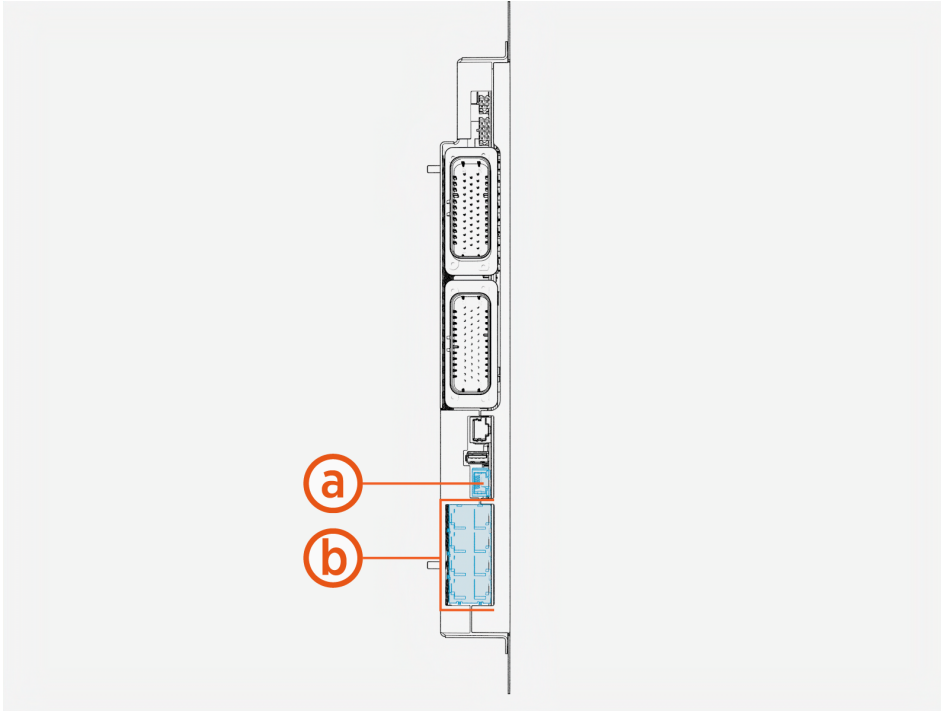

- (a) Hardwire Ethernet port.
  - (b) Ethernet ports for connection to Power Link or another Express Solo. There are eight ports and all ports are equivalent.
2. Route the Ethernet cables through the wireway clamps up to the PMC.

3. Install each Ethernet cable with the following steps:
  - a. Trim Ethernet (Cat6 STP) cable to length, allowing for a service loop.
  - b. Field crimp a shielded RJ45 connector onto the Ethernet cable. Use straight-through T568B pattern.

**IMPORTANT:**

- If the Ethernet cable connects from the Express Solo to a Power Link, ground the cable shield at the Express Solo end (and not at the Power Link end).
- If the Ethernet cable connects between two Express Solos, ground the cable shield at only one Express Solo. That Express Solo is designated as the main unit within the cluster.

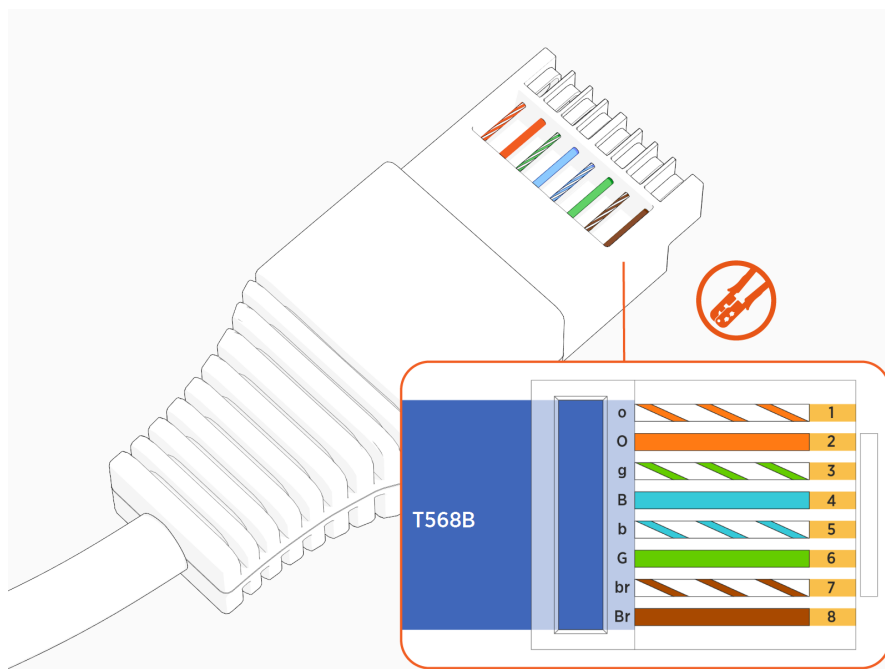

c. Test the Ethernet cable for functionality.



**IMPORTANT:** If using a Paige OSP Shielded GameChanger cable for a wire run length greater than 100 m (328 ft), follow the test procedure specified by Paige. See [Paige GameChanger Resources](#).

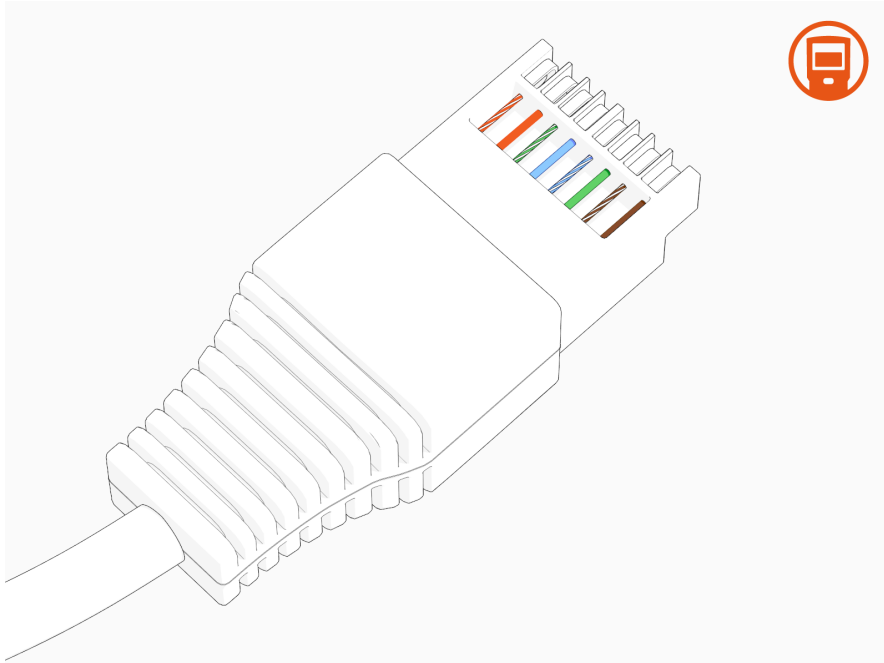

- d. Insert the Ethernet cable into the appropriate Ethernet port. To establish a secure connection, the RJ45 connector latch must click into the switch.

Inserting hardwire Ethernet cable:

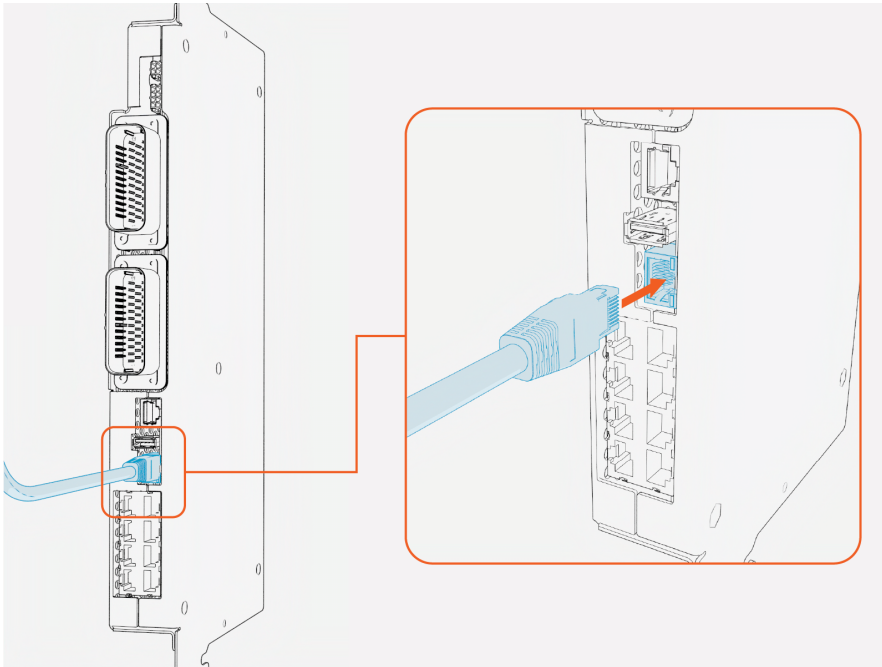

Inserting Ethernet cable that connects to Power Link or other Express Solo:

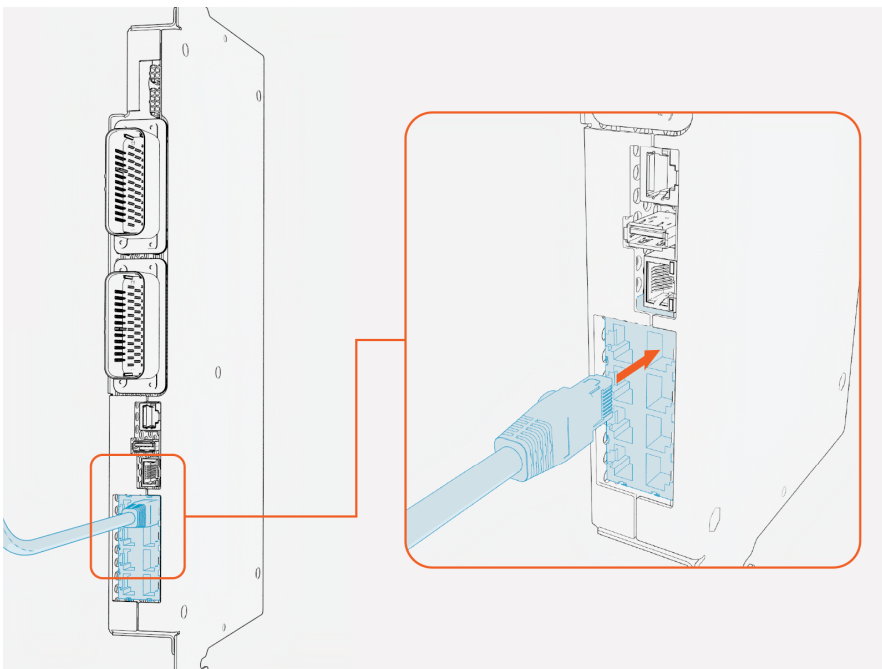

# Connect Door Interlock Sensor and Soft Shutdown Switch Wires

Follow steps below to connect the door interlock sensor and soft shutdown switch wires, as needed.

1. Use the [wire landings diagram](#) to locate the door interlock sensor terminal and soft shutdown switch terminals within the cabinet. The terminals are accessible on the intake side (right side) of Express Solo. The procedure for installing wires at each terminal is the same.

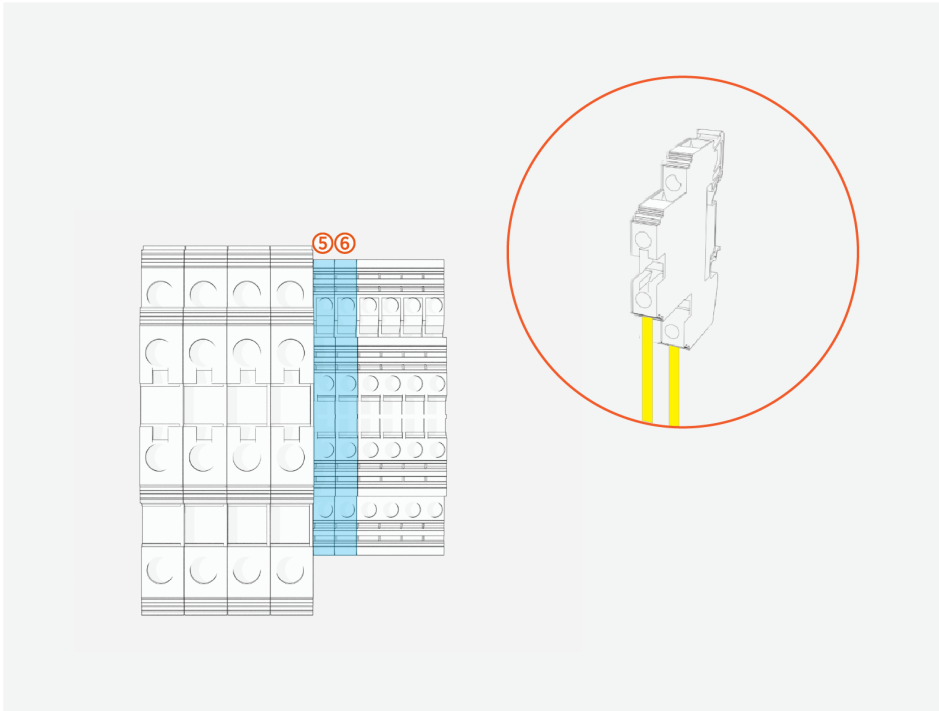

(5) Soft shutdown switch terminal

(6) Door interlock sensor terminal

## IMPORTANT:



- Each terminal has:
  - Upper-level wire insertion point with a corresponding set screw
  - Lower-level wire insertion point with a corresponding set screw
- The soft shutdown switch wires are non-polarized and interchangeable. Either wire can be installed into either level on the soft shutdown switch terminal (5).
- The door interlock sensor wires are non-polarized and interchangeable. Either wire can be installed into either level on the door interlock sensor terminal (6).
- Do not confuse the soft shutdown switch terminal (5) with the door interlock sensor terminal (6). These terminals are *not* interchangeable.

2. Follow procedures below to connect a wire pair at its designated terminal:
  - a. Twist the wires together, using a minimum of five twists per foot.

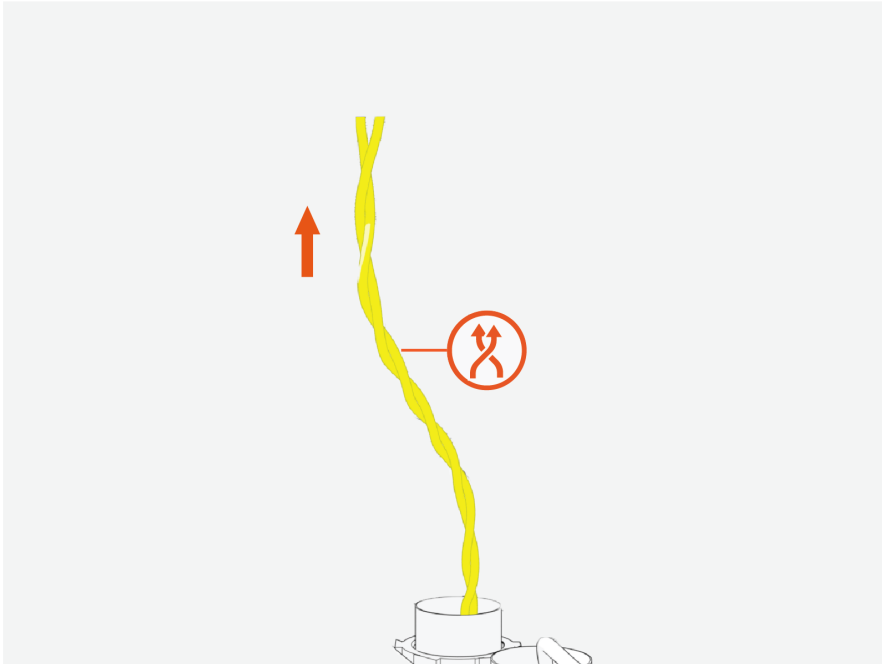

- b. Route the twisted wire pair through the wireway clamps up to the terminal. If necessary use cable ties.
    - c. Cut the wires to length for landing at the terminals.

- d. Strip the wire jackets. If using wire ferrules, install the ferrules after stripping the conductor.

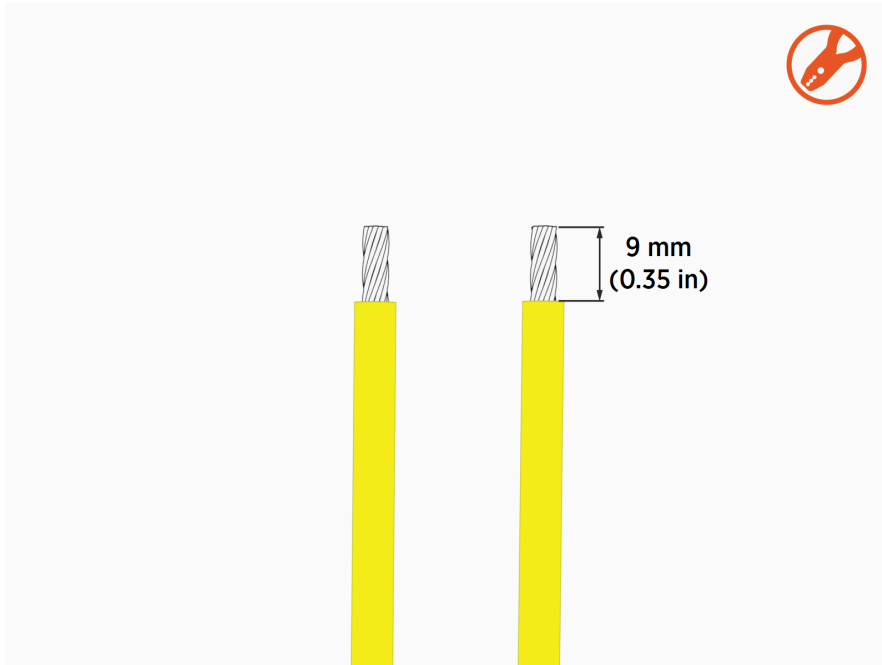

- e. At the wire terminal, loosen the wire set screws (x2). Use a 3.5 mm flathead screwdriver.  
f. Insert the wires into the terminal. Torque the set screws (x2) to **0.6 Nm (5.3 in-lb)**.

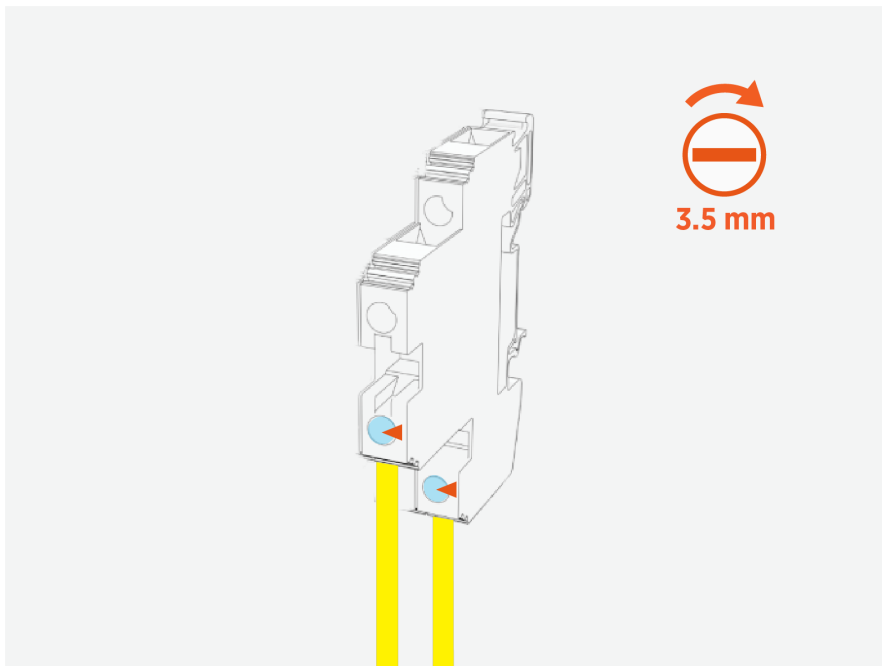

- g. Push-pull to test that both wires (+ and -) are secured.

## Connect Safety Hub Wires

Safety Hub wiring provides electrical-isolation monitoring between the Express Solo and each connected Power Link.

Depending on the Power Link model used in the installation, the Safety Hub connection at the Express Solo will require either:

- A twisted-pair field-wire connection, or
- A jumper installed on the Safety Hub Board

Contact [ChargePoint](#) to confirm whether the Power Link used in your project requires a Safety Hub twisted-pair connection or a jumper installation. Then proceed through the applicable sections below to install the required wiring.

## Identify Safety Hub Board Location, Terminals, and Pin Ports

Refer to [Wire Terminal and Bus Bar Locations](#) to locate the Safety Hub board within the Express Solo cabinet.

The Express Solo includes two external HV DC outputs—EXT B and EXT D—used to supply charging power to Power Links. The Safety Hub Board provides four terminals (A, B, C, D), shown below. Terminals B and D correspond to the Power Links connected through the EXT B and EXT D outputs, respectively. Terminals A and C correspond to the DC BUS positions and are not used for Power Link connections.

Terminals B and D each have a terminal block plug with five pin ports, numbered 1–5.

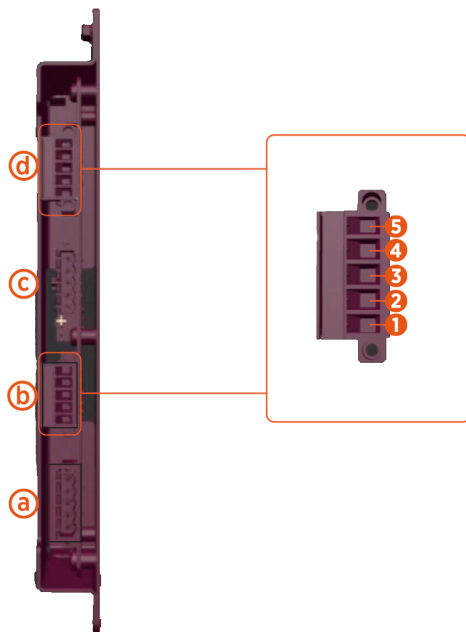

- (a) Terminal A (not used)
- (b) Terminal B (corresponds to the Power Link connected at EXT B output)

(c) Terminal C (not used)

(d) Terminal D (corresponds to the Power Link connected at EXT B output)

## Install Jumper Wire

If the Express Solo connects to a Power Link model that requires jumper wire installation at the Safety Hub Board, follow steps below to install a jumper wire at each appropriate terminal of the Safety Hub Board.



**NOTE:** The jumper wire is provided with the Power Link.

1. Identify the terminal on the Safety Hub Board. Refer to [Identify Safety Hub Board Location, Terminals, and Pin Ports](#).
2. Fully loosen the captive screws (x2) on the terminal block plug.

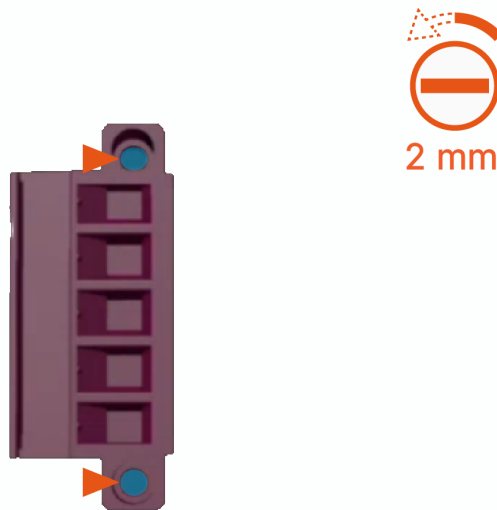

3. Pull the terminal block plug out from the Safety Hub Board.

4. Install a jumper cable into the plug, using the following steps:
  - a. Locate the jumper wire (supplied with the Power Link).



- b. Loosen the set screws for pin ports #1 and #5.

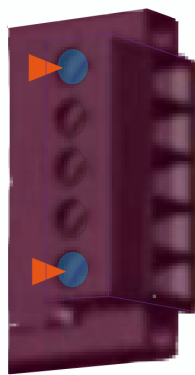

- c. Insert the jumper wire ends into pin ports #1 and #5. Then tighten the set screws to **0.5 Nm (4.4 in-lb)**. Push-pull to confirm the jumper is secure.



5. Reinstall the terminal block plug at the Safety Hub Board. Use a 2 mm flathead screwdriver and tighten the captive screws (x2) to **0.3 Nm (2.7 in-lb)**.

## Connect Shunt Trip Wires

TBD

# Set Up Charging Cables 5

Follow all instructions provided in this chapter to set up the charging cables.

## Install Overhead CMK (if applicable)

If the site plan calls for the Express Solo to be configured with an overhead CMK, follow procedures in this section to install the CMK.



**IMPORTANT:** The site must be equipped with poles for mounting the overhead CMK next to each of the Express Solo charging cables. The poles must meet the design specifications given in the *Express Solo Site Design Guide*.

## Install Overhead CMK

Follow steps below to install the overhead CMKs.

1. Find the M8 hex nuts (x4) and M6 Torx screws (x4) shipped in the overhead CMK package.
2. Install the bracket onto the pole.

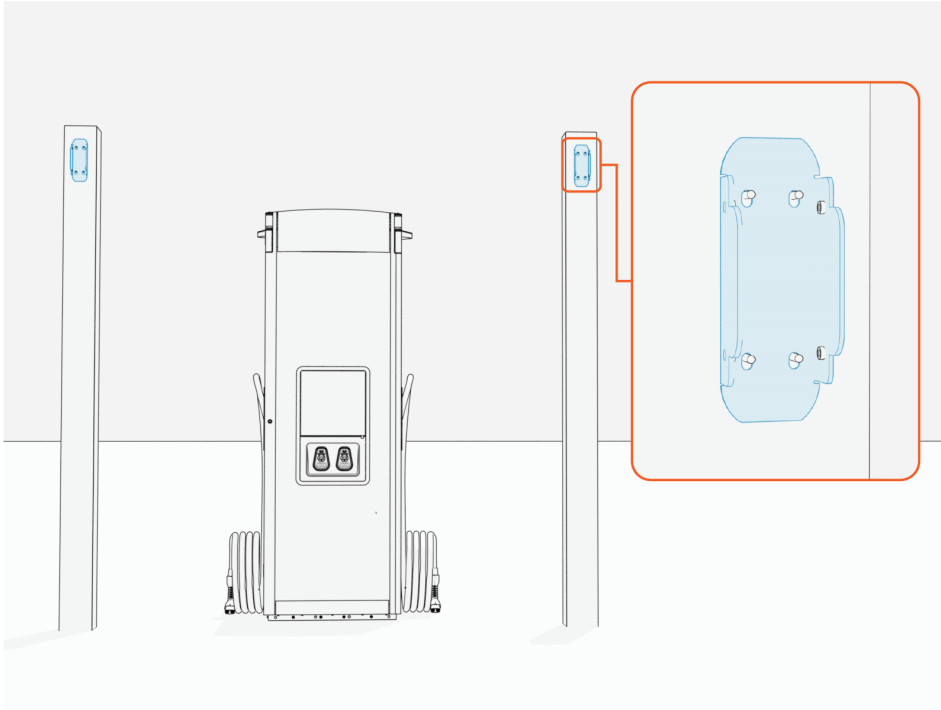

3. Install and torque the M8 hex nuts (x4) to **12.2 Nm (108 in-lb)** to secure the bracket.

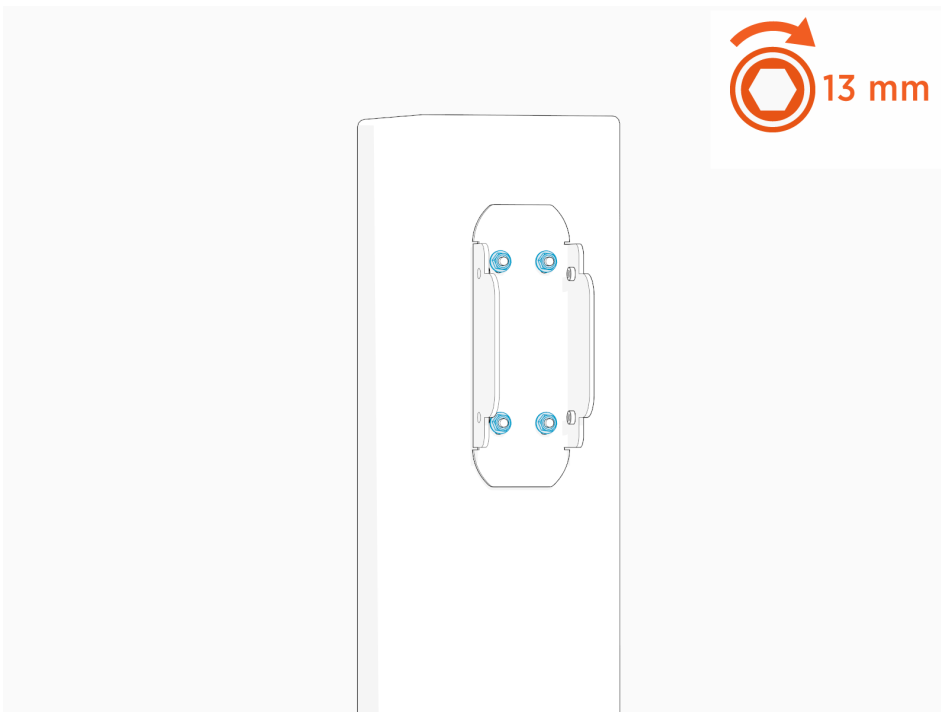

- 
- Align the overhead CMK onto the bracket and install M6 Torx screws (x4, x2 on the left side and x2 on the right side).

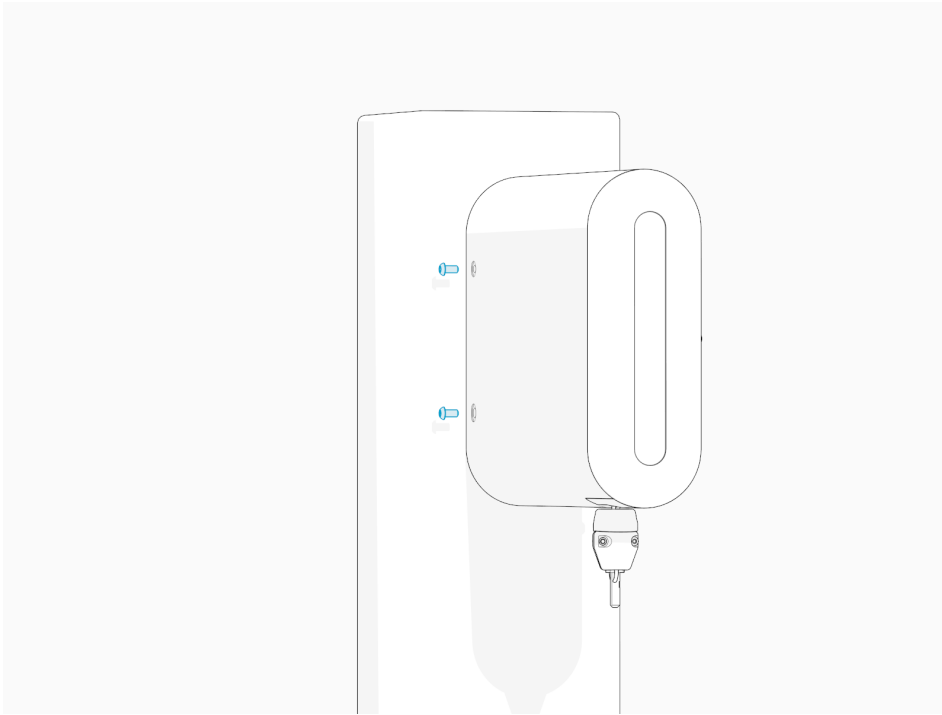

- Torque the screws to **3.4 Nm (30 in-lb)**.

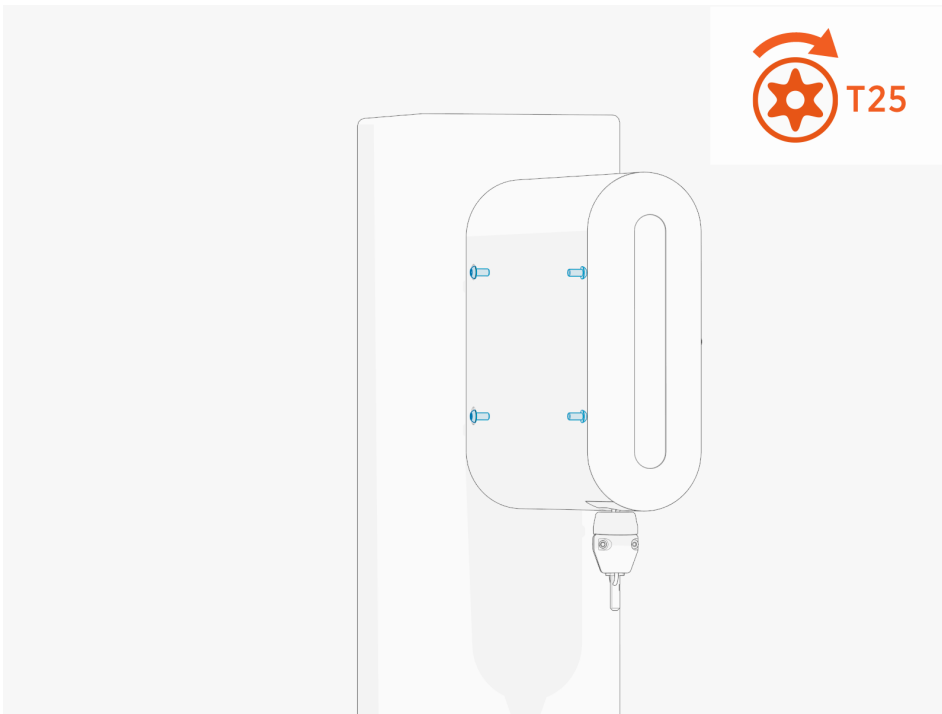

# Install Charging Cable Tetherballs

Standard length (5.8 m or 19 ft) charging cables come with a tetherball preinstalled onto the cable. For non-LCC medium length (7.6 m or 25 ft) charging cables, a tetherball is not preinstalled onto the cable and you must follow steps below to install tetherballs onto each charging cable (if not already done).

Illustrations given below are based on the swingarm CMK, but the concept at each step applies to all cable management options.

1. Loosely install the tetherball onto the cable.

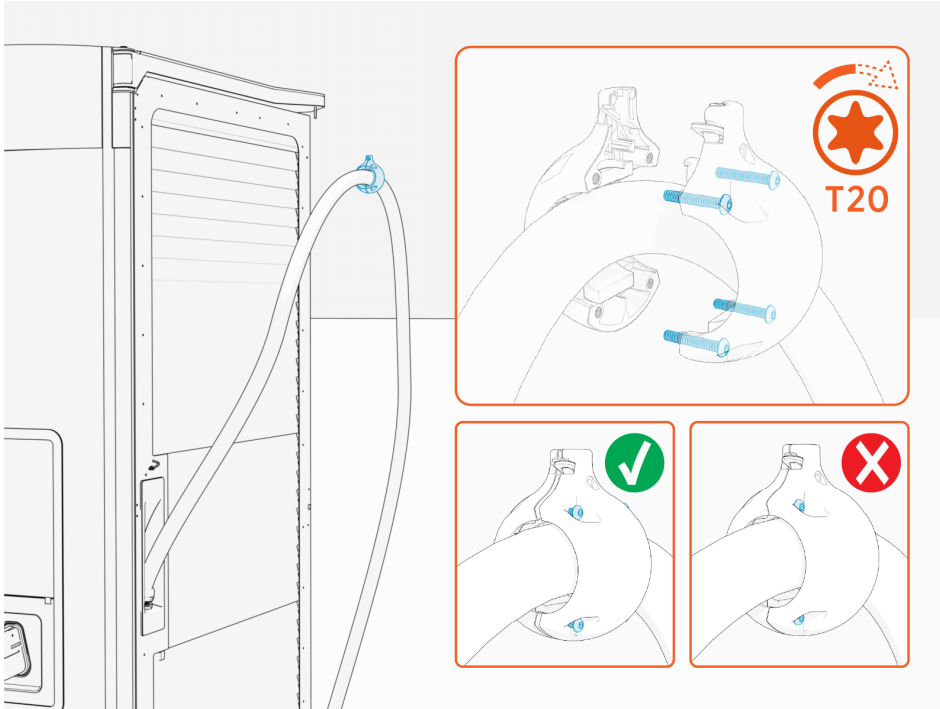

2. If necessary, slide the tetherball to a position on the cable such that the lowest point of the cable remains 25 mm (1in) off the ground when the cable is in its stored position.

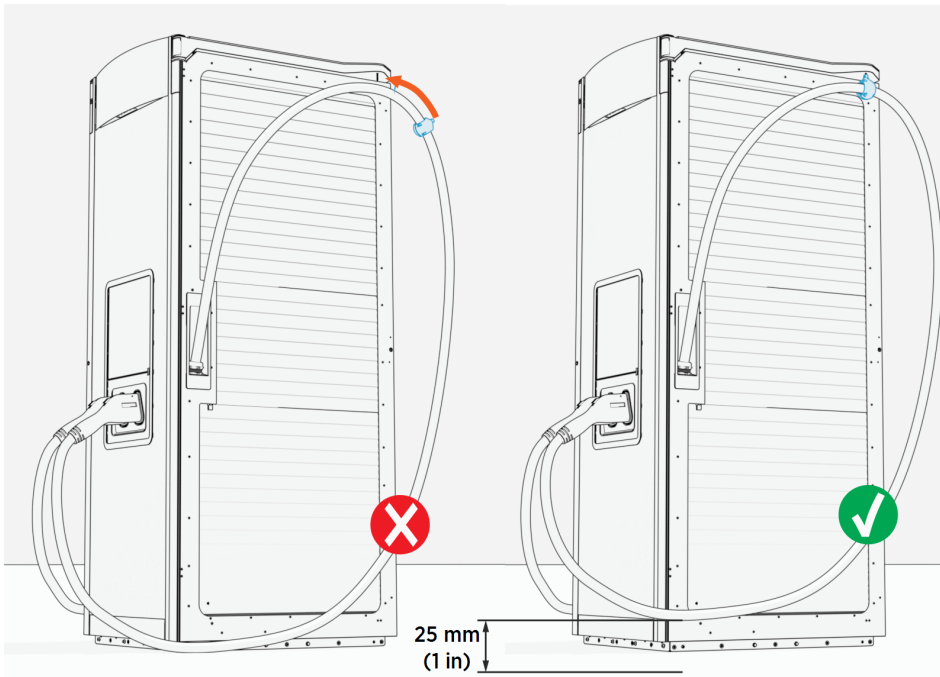

3. Torque the screws (x4) to **2.8 Nm (25 in-lb)**.

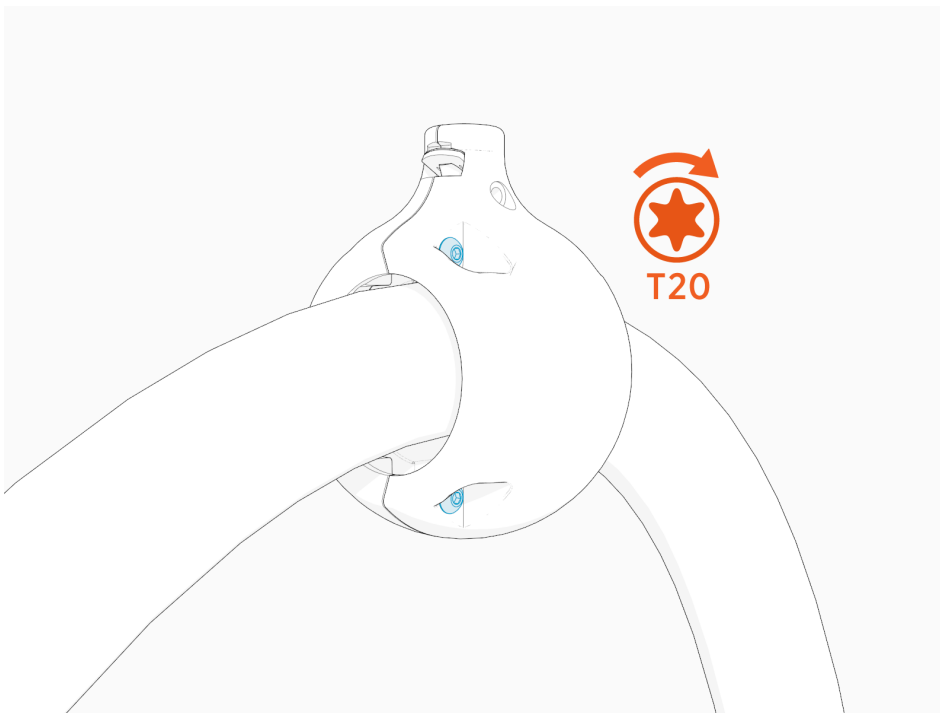

# Suspend Charging Cables

The procedure for suspending charging cables is the same, whether Express Solo is configured with fixed tether point, swingarm CMK, or overhead CMK. The charging cable tetherball must be affixed to a tetherball anchor pin on the cable management system.

Follow steps below to suspend the charging cables (if not already done). Illustrations given below are based on the swingarm CMK, but the concept at each step applies to all cable management options.

1. If it is not already loose, loosen (do not remove) the tetherball set screw.

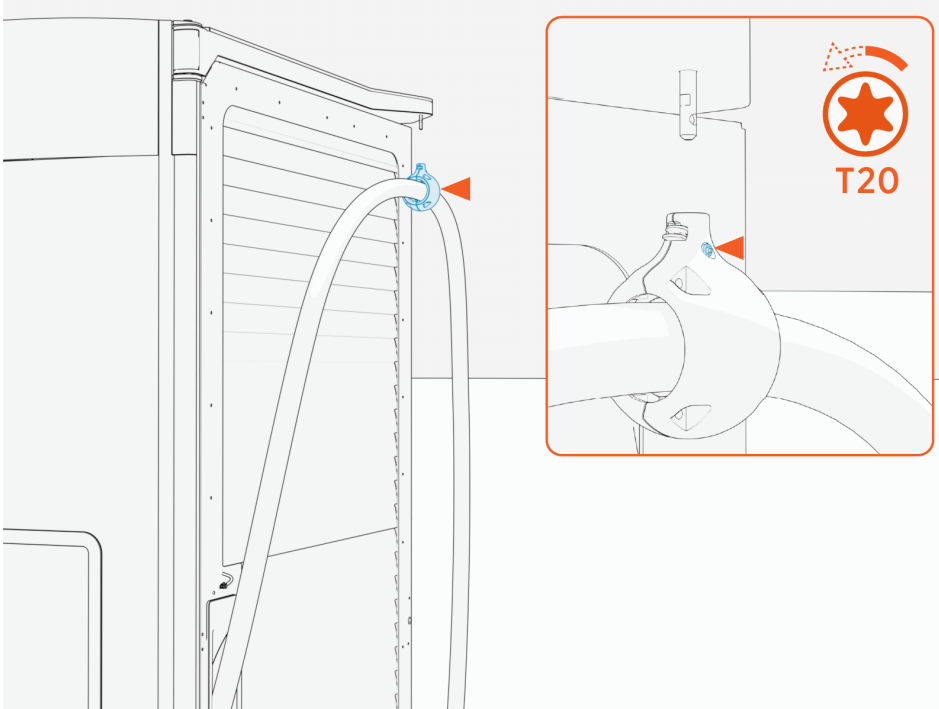

- Align the tetherball spring tab with the flat notch on the anchor pin. While aligned, gently push the tetherball onto the anchor pin.

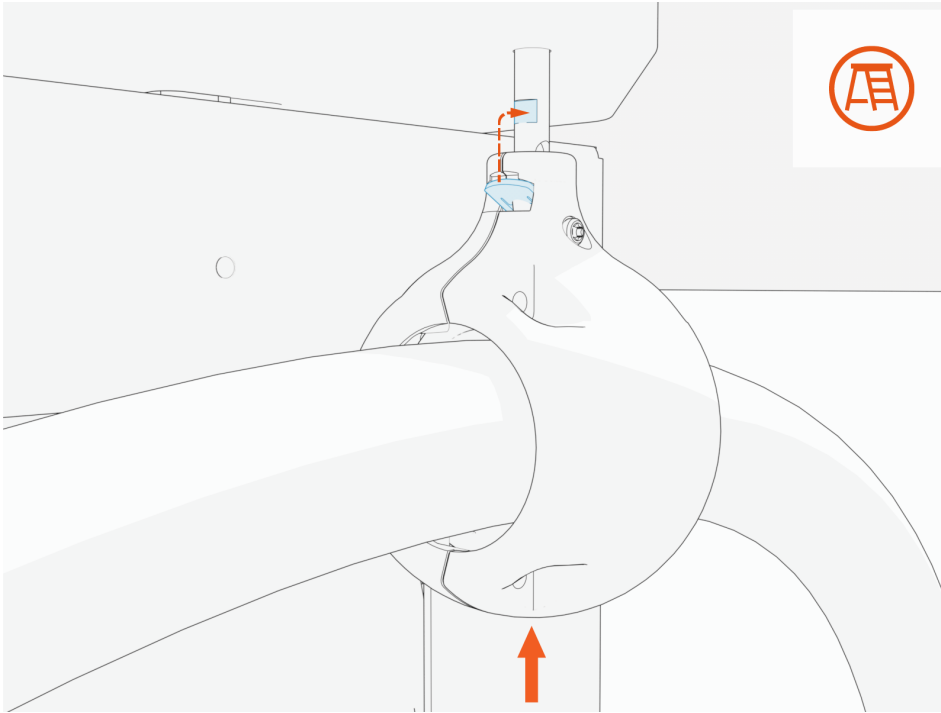

- Torque the set screw to **2.8 Nm (25 in-lb)**.

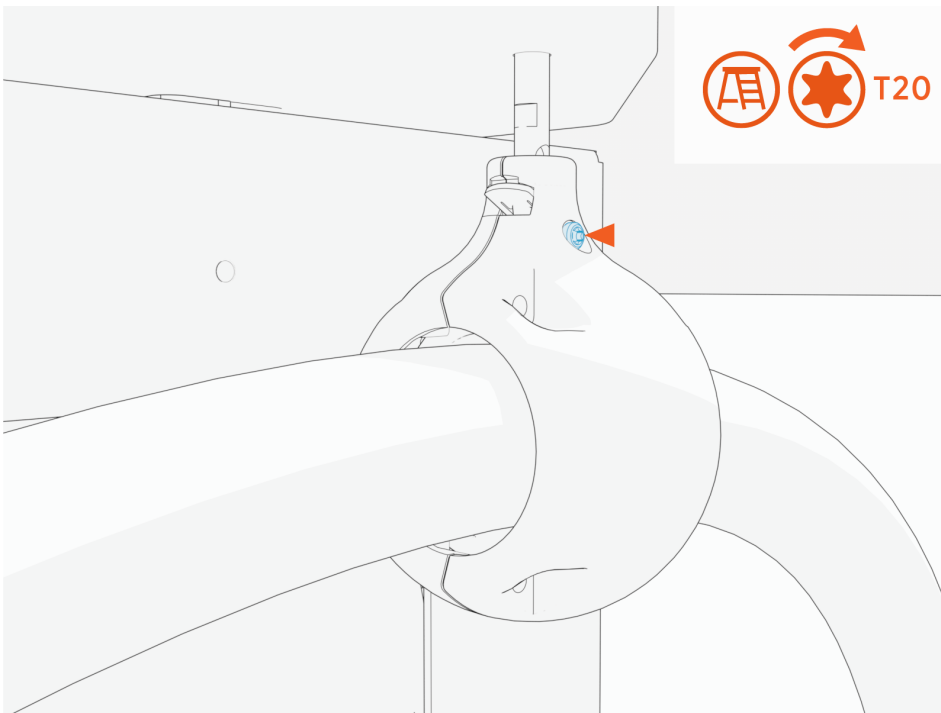

4. Tug on the cable to check that it is securely attached and the swingarm is functioning. If you find limited motion or retraction, contact ChargePoint.

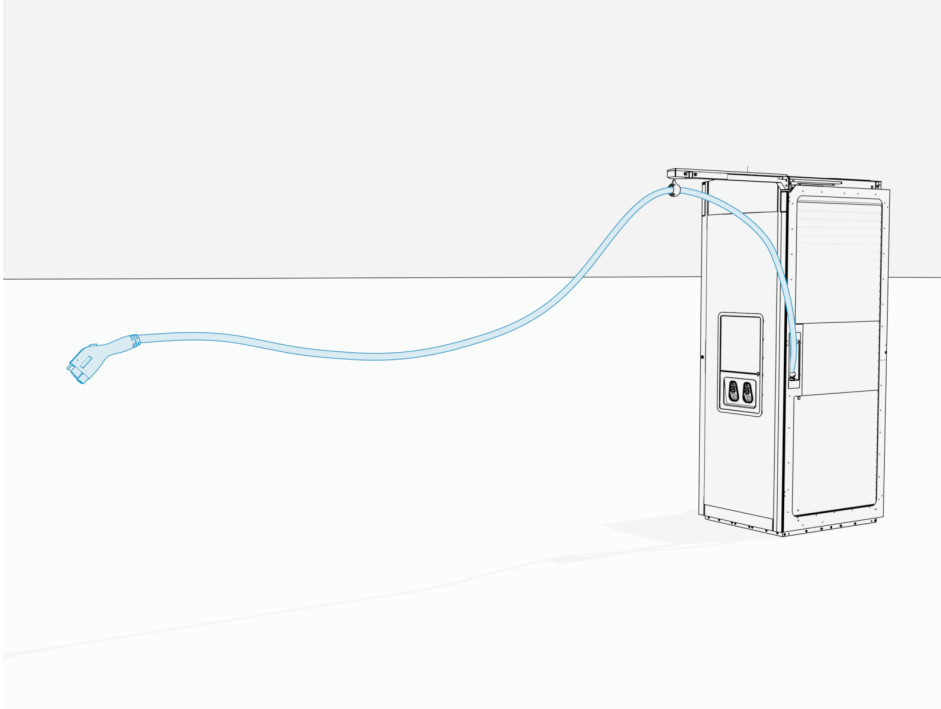

5. Insert the charging cable connector into the corresponding holster.

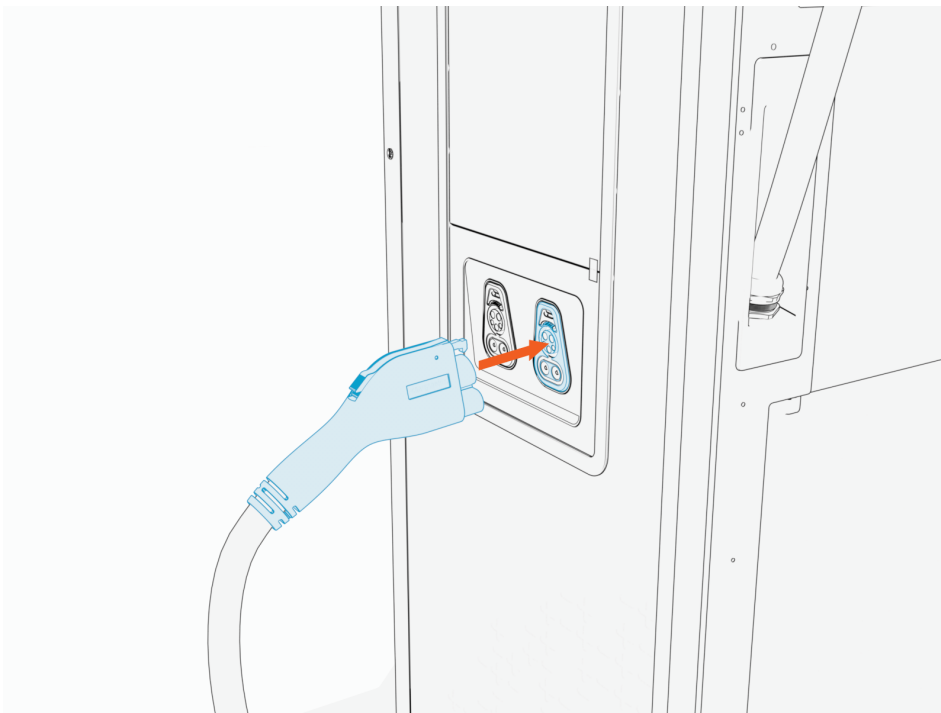

6. Repeat the steps above to suspend the other charging cable.

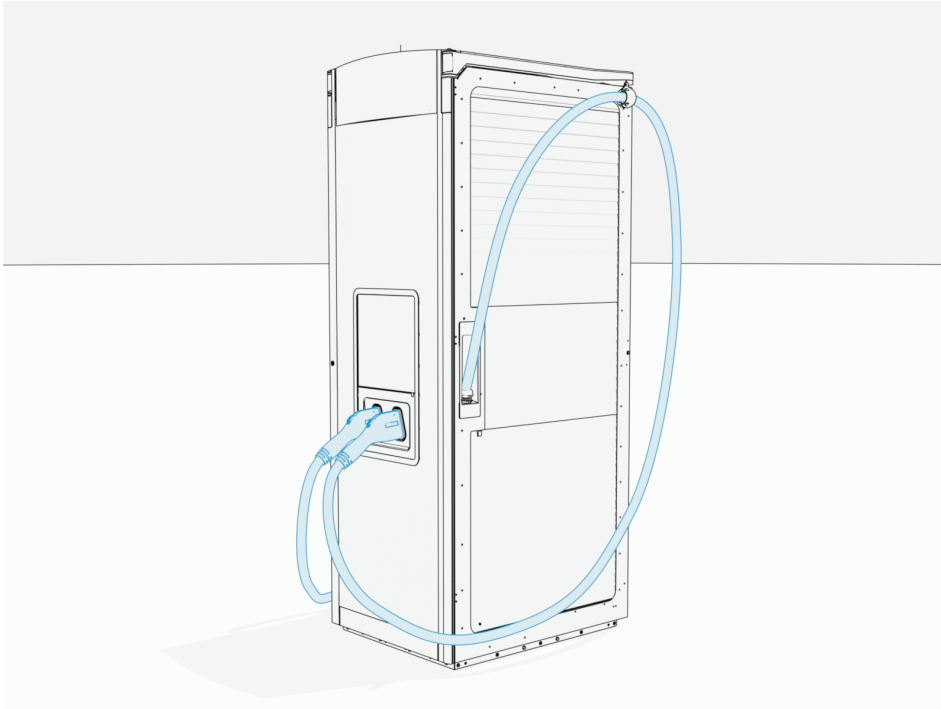

# Complete the Install 6

Follow all instructions provided in this chapter to complete the installation.

## Complete the Installation Checklist

To adhere to ChargePoint best practices, complete the *Express Solo Installation Checklist*, available at [ChargePoint Product Reference Documentation](#).



**NOTE:** Some checklist items require the charging station be open and safety shields removed. Other checklist items apply after [installing safety shields](#) and [closing the station](#).

## Reinstall Safety Shields

Follow procedures below to reinstall all safety shields.

### DC Bus Bars Safety Cover (Intake Side)

1. Seat the cover back into its original place. Slide the cover downward so the keyholes lock behind the retaining nuts.
2. Tighten the upper nuts (x3) to **1.7 Nm (15 in-lb)**. Use a 7 mm socket. Tighten the lower nuts (x3) to **4.5 Nm (40 in-lb)**. Use an 8 mm socket.

### DC Terminals Safety Cover (Intake Side)

1. Seat the cover back into its original place. Slide the cover downward so the keyholes lock behind the retaining nuts.



**NOTE:** Route the Ethernet cables behind the cover and up through the cutout located in the upper right corner of the cover. If needed, use a cable tie to neatly bundle the cables. Make sure the cables are not pinched or excessively bent as they pass through the cutout.

2. Tighten the nuts (x2) to **4.5 Nm (40 in-lb)**. Use an 8 mm socket.

## Shunt Trip Terminals Safety Cover (Intake Side)

TBD: Instructions shall be provided in a future release.

## AC Bus Bars Safety Cover (Exhaust Side)

1. Seat the cover back into its original place. Slide the cover downward so the keyholes lock behind the retaining nuts.
2. Tighten the nuts (x2) to **5.6 Nm (50 in-lb)**. Use a T30 screwdriver.

## DC Bus Bars Safety Cover (Exhaust Side)

1. Seat the cover back into its original place. Slide the cover downward so the keyholes lock behind the retaining nuts.
2. Tighten the nuts (x5) to **4.5 Nm (40 in-lb)**. Use an 8 mm socket.

## DC Fuse Block Safety Cover (Exhaust Side)

1. Seat the cover back into its original place. Slide the cover downward so the keyholes lock behind the retaining nuts.
2. Tighten the nuts (x2) to **2.8 Nm (25 in-lb)**. Use an 8 mm socket.

## Close Up Express Solo

1. Disengage the door stopper and close the cabinet doors.
2. Lock the cabinet doors.
3. Plug the locks on the side doors.

# Appendix: Low Clearance Forklift **A** Bracket Lift

Forklift brackets may be installed on Express Solo to enable product installation at a location where the overhead clearance does not meet the minimum requirement.

TBD: Forklift bracket installation instructions shall be provided in future release.

# Appendix: Set Up Express Solo B

To set up Express Solo, complete the following steps:



**IMPORTANT: Do not power on Express Solo immediately after installation.**

Express Solo must not be powered on after installation. A certified Authorized Commissioning Partner (ACP) is required to commission the station before it is energized. The ACP will perform all necessary configuration and verification steps to ensure proper operation.

To schedule a commissioning appointment, [contact ChargePoint](#). Be ready to provide the station serial number (SN).

## Power On



**NOTE:** Express Solo must pass commissioning before power on, or warranty limitations apply.

1. Ensure all safety panels have been correctly installed, all doors are closed and locked, and all other parts have been correctly installed and the work is complete.
2. Turn on power at the same points that you turned it off.



**NOTE:** If the site has a remote shunt trip switch, ensure that the switch is in the operating position.

- Wait for self-diagnostics to run. The system may take several minutes to initiate. You may see messages intermittently until the system fully boots up.





Self-Diagnostic	After Installation	After Service or Power Outage
Electrical safety checks	✓	✓
Lighting checks	✓	✓
Display panel checks	✓	✓
Component operation checks	✓	✓
Network connectivity checks	✓	✓
Installation Wizard (for the installer to complete configuration and pinpoint the station on maps)	✓	—

## Set Up Express Solo

After you power on the charging station at the breaker panel, set up Express Solo. To do so, you need:

- ChargePoint installer login credentials.
- Activation label (QR code label including the MAC address and activation password).
- The exact location (to the parking space) where the Express Solo is installed.
- A smartphone with ChargePoint Installer app, Internet connectivity, and QR code scanner (usually built into the camera app).

Scan the QR code to download the ChargePointInstaller app and sign up if necessary.

Region (Language)	QR Code	Region	QR Code
United States		France	
Canada (French)		Germany	
United Kingdom			

Follow the steps below to set up Express Solo:

1. Open the ChargePoint Installer app and log in.
2. Follow the onscreen prompts.



**NOTE:** To connect to Express Solo and complete setup, you need to scan the QR code provided on the Express Solo display or manually enter the MAC address and password of Express Solo.

---

## Limited Warranty Information and Disclaimer

The Limited Warranty you received with your charging station is subject to certain exceptions and exclusions. For example, your use of, installation of, or modification to, the ChargePoint® charging station in a manner in which the ChargePoint® charging station is not intended to be used or modified will void the limited warranty. You should review your limited warranty and become familiar with the terms thereof. Other than any such limited warranty, the ChargePoint products are provided "AS IS," and ChargePoint, Inc. and its distributors expressly disclaim all implied warranties, including any warranty of design, merchantability, fitness for a particular purposes and non-infringement, to the maximum extent permitted by law.

### Limitation of Liability

CHARGEPOINT IS NOT LIABLE FOR ANY DIRECT, INDIRECT, INCIDENTAL, SPECIAL, PUNITIVE OR CONSEQUENTIAL DAMAGES, INCLUDING WITHOUT LIMITATION LOST PROFITS, LOST BUSINESS, LOST DATA, LOSS OF USE, OR COST OF COVER INCURRED BY YOU ARISING OUT OF OR RELATED TO YOUR PURCHASE OR USE OF, OR INABILITY TO USE, THE CHARGING STATION, UNDER ANY THEORY OF LIABILITY, WHETHER IN AN ACTION IN CONTRACT, STRICT LIABILITY, TORT (INCLUDING NEGLIGENCE) OR OTHER LEGAL OR EQUITABLE THEORY, EVEN IF CHARGEPOINT KNEW OR SHOULD HAVE KNOWN OF THE POSSIBILITY OF SUCH DAMAGES. IN ANY EVENT, THE CUMULATIVE LIABILITY OF CHARGEPOINT FOR ALL CLAIMS WHATSOEVER RELATED TO THE CHARGING STATION WILL NOT EXCEED THE PRICE YOU PAID FOR THE CHARGING STATION. THE LIMITATIONS SET FORTH HEREIN ARE INTENDED TO LIMIT THE LIABILITY OF CHARGEPOINT AND SHALL APPLY NOTWITHSTANDING ANY FAILURE OF ESSENTIAL PURPOSE OF ANY LIMITED REMEDY.

### FCC Compliance Statement

Refer to the ChargePoint product nameplate to determine if your product is Class A or Class B.

- **Class A Statement:** This equipment has been tested and found to comply with the limits for a Class A digital device pursuant to Part 15 of the FCC Rules. These limits are designed to provide reasonable protection against harmful interference when the equipment is operated in a commercial environment. This equipment generates, uses, and can radiate radio frequency energy and, if not installed and used in accordance with the manufacturer's instruction manual, may cause harmful interference with radio communications. Operation of this equipment in a residential area is likely to cause harmful interference, in which case, you will be required to correct the interference at your own expense.

Important: Changes or modifications to this product not authorized by ChargePoint, Inc., could affect the EMC compliance and revoke your authority to operate this product.

Exposure to Radio Frequency Energy: The radiated power output of the 802.11 b/g/n radio and cellular modem (optional) in this device is below the FCC radio frequency exposure limits for uncontrolled equipment. The antenna of this product, used under normal conditions, is at least 20 cm away from the body of the user. This device must not be co-located or operated with any other antenna or transmitter by the manufacturer, subject to the conditions of the FCC Grant.

- **Class B Statement:** This equipment has been tested and found to comply with the limits for a Class B digital device, pursuant to part 15 of the FCC Rules. These limits are designed to provide reasonable protection against harmful interference when the equipment is operated in a residential installation. This equipment generates, uses, and can radiate radio frequency energy and, if not installed and used in accordance with the instruction manual, may cause harmful interference to radio communications.

Important: Changes or modifications to this product not authorized by ChargePoint, inc., could affect the EMC compliance and revoke your authority to operate this product.

Exposure to Radio Frequency Energy: The radiated power output of the 802.11 b/g/n radio and cellular modem (optional) in this device is below the FCC radio frequency exposure limits for uncontrolled equipment. The antenna of this product, used under normal conditions, is at least 20 cm away from the body of the user. This device must not be co-located or operated with any other antenna or transmitter by the manufacturer, subject to the conditions of the FCC Grant.

## ISED (formerly Industry Canada)

This device complies with the licence-exempt RSS standard(s) of Innovation, Science and Economic Development Canada (ISED). Operation is subject to the following two conditions: (1) this device may not cause interference, and (2) this device must accept any interference, including interference that may cause undesired operation of the device.

Cet appareil est conforme aux flux RSS exemptés de licence d'Innovation, Sciences et Développement économique Canada (ISDE). L'exploitation est autorisée aux deux conditions suivantes : (1) l'appareil ne doit pas produire de brouillage, et (2) l'utilisateur de l'appareil doit accepter.

Radiation Exposure Statement: This equipment complies with the IC RSS-102 radiation exposure limits set forth for an uncontrolled environment. This equipment should be installed and operated with a minimum distance of 20 cm between the radiator and your body.

Énoncé d'exposition aux rayonnements: Cet équipement est conforme aux limites d'exposition aux rayonnements ioniques RSS-102 Pour un environnement incontrôlé. Cet équipement doit être installé et utilisé avec un Distance minimale de 20 cm entre le radiateur et votre corps.

## FCC/IC Compliance Labels

Visit [chargepoint.com/labels](http://chargepoint.com/labels).