

Express Solo

One Platform, Infinite Possibilities

Site Design Guide for Europe



IMPORTANT SAFETY INSTRUCTIONS

SAVE THESE INSTRUCTIONS

This manual contains important instructions for ChargePoint® products that shall be followed during installation, operation and maintenance of each product.

WARNING:



1. **Read and follow all warnings and instructions before servicing, installing, or operating the ChargePoint® product.** Install and operate only as instructed. Failure to do so may lead to death, injury, or property damage, and will void the Limited Warranty.
2. **ChargePoint recommends that installation, commissioning, and break-fix services be performed by a licensed electrician who is also a ChargePoint-certified technician.** These systems operate at high voltage, and without strict adherence to safety protocols, proper protective equipment, and ChargePoint technical guides, there is significant risk to people, equipment, and the environment. Please ensure full compliance with all applicable local and national buildings, electrical, and safety codes.
3. **Always ground the ChargePoint product.** A touch current of >3.5 mA AC RMS is possible in case of a fault condition of loss of electrical continuity of the earthing conductor. Failure to ground the product can lead to risk of electric shock. The product must be connected to a grounded, metal, permanent wiring system, or an equipment grounding conductor shall be run with circuit conductors and connected to the equipment grounding terminal or lead on the Electric Vehicle Supply Equipment (EVSE). Connections to the EVSE shall comply with all applicable codes and ordinances.
4. **Install the ChargePoint product using a ChargePoint-approved method.** Failure to install on a surface that can support the full weight of the product can result in death, personal injury, or property damage. Inspect the product for proper installation before use.
5. **The product is not suitable for use in Class 1 hazardous locations, such as near flammable, explosive, or combustible vapors or gases.**
6. **Supervise children near this device.**
7. **Do not put fingers into the electric vehicle connector or connector adapter. Do not touch fingers to charging rails.**
8. **Do not use this product if any cable is frayed, has broken insulation, or shows any other signs of damage.**
9. **Do not use this product if the enclosure, the flexible output cable, the vehicle inlet, the electric vehicle connector, or the electric vehicle connector adapter is broken, cracked, open, or shows any other signs of damage. Do not use this product if internal parts are accessible, including wiring.**
10. **Wire and wire terminal information are provided in the ChargePoint product Site Design Guide and Installation Guide.**

11. **Torques for installation of wire terminals are provided in the ChargePoint product Installation Guide.**
12. **The ChargePoint product maximum operating temperature is 50 °C (122 °F).**
13. **Do not use an electric vehicle connector adapter with any charger or EV that is capable of exceeding the adapter's rated voltage of current capacity. Some EVs and EVSE combinations are capable of multiple voltages or limited durations of current overloading designed for normal EVSE-to-EV connections. Use of an electric vehicle connector adapter in these situations could result in unsafe conditions such as fire, burns, or exposure of high voltage.**



IMPORTANT: Under no circumstances will compliance with the information in a ChargePoint guide such as this one relieve the user of the responsibility to comply with all applicable codes and safety standards. This document describes approved procedures. If it is not possible to perform the procedures as indicated, contact ChargePoint. ChargePoint is not responsible for any damages that may result from custom installations or procedures not described in this document or that fail to adhere to ChargePoint recommendations.

Warranty Implication



IMPORTANT: Please be advised that all installation, commissioning, and break-fix services must be performed by a ChargePoint-certified technician. Engaging non-certified personnel for these services will result in warranty implications, as doing so constitutes a breach of policy.

Support Services

<https://www.chargepoint.com/legal/support-services>

For more information about ChargePoint's training and certification program, visit <https://www.chargepoint.com/partners/training-certification>

Product Disposal

To comply with Directive 2012/19/EU of the European Parliament and of the Council of 4 July 2012 on waste electrical and electronic equipment (WEEE), devices marked with this symbol may not be disposed of as part of unsorted domestic waste inside the European Union. Enquire with local authorities regarding proper disposal. Product materials are recyclable as marked.



Document Accuracy

The specifications and other information in this document were verified to be accurate and complete at the time of its publication. However, due to ongoing product improvement, this information is subject to change at any time without prior notice. For the latest information, see our documentation online at [ChargePoint Product Reference Documentation](#).

Copyright and Trademarks

©2013-2026 ChargePoint, Inc. All rights reserved. This material is protected by the copyright laws of the United States and other countries. It may not be modified, reproduced, or distributed without the prior, express written consent of ChargePoint, Inc. ChargePoint and the ChargePoint logo are trademarks of ChargePoint, Inc., registered in the United States and other countries, and cannot be used without the prior written consent of ChargePoint.

Symbols

This guide and product use the following symbols:



DANGER: Risk of electric shock



WARNING: Risk of personal harm or death



CAUTION: Risk of equipment or property damage



IMPORTANT: Critical detail that must be followed to achieve intended results



NOTE: Important contextual details or procedural clarifications



REINSTALL NOTE: Essential instructions to follow when reinstalling a part or component



Read the manual for instructions



Ground/protective earth

Illustrations Used in This Document

The illustrations used in this document are for demonstration purposes only and may not be an exact representation of the product. However, unless otherwise specified, the underlying instructions are accurate for the product.

Contents

- IMPORTANT SAFETY INSTRUCTIONS i
- Revision History vi
- 1 Introduction 1**
 - About This Guide 1
 - Express Solo Overview 1
 - Product Guides 9
 - Questions 9
- 2 Site Planning and Placement 10**
 - Initial Site Guidelines 10
 - Plan for Future Charging Capacity 10
 - System Placement 11
- 3 Civil and Mechanical Design 18**
 - Dimensions 18
 - Weights 19
 - Mount Specifications 19
 - Drainage 24
 - Flood Plane 24
 - Clearances 25
 - Bollards 26
 - Ventilation 27
 - Accessibility 27
 - Signage 27
- 4 Electrical Design 29**
 - Electrical Supply Requirements 29
 - Grounding Requirements 31
 - Soft Shutdown 31
 - Hardwire Ethernet 32
 - Safety Hub 32
 - Wiring and Conduit Requirements 33
- 5 Connectivity 42**
 - Signal Strength and Quality 42

Repeaters 44

Revision History

This page provides a summary of revisions made, listing the month and year of each update along with a brief description of the changes made.

Month & Year	Description
Apr 2026	Initial release of early draft.

Introduction 1

This section defines the purpose of this guide and provides an introduction to the ChargePoint® Express Solo.

About This Guide

This guide outlines the requirements and best practices for designing project sites that will host the ChargePoint Express Solo. It covers electrical infrastructure requirements, capacity planning, conduit and concrete work, site layout considerations, and cellular signal requirements needed to prepare a site for installation.

This guide is intended for site designers, electrical engineers, project planners, architects, and construction professionals responsible for preparing a site for Express Solo deployment.



IMPORTANT: You must be a licensed electrician and complete online training to become a ChargePoint certified installer. If you do not complete training, you cannot access the ChargePoint network to complete installation. Find online training at: <https://www.chargepoint.com/partners/training-certification>. If the charging station is not installed by a ChargePoint certified installer, using a ChargePoint approved method, it is not covered under warranty and ChargePoint is not responsible for any malfunctions.

Express Solo Overview

Express Solo is a product within the Express DC fast charging platform. Express Solo operates as both a standalone charging station and a power cabinet. It accepts AC input power, converts it to DC, and delivers power to two integrated charging cables. It can also simultaneously supply power to downstream EVSEs such as external Power Link charging dispensers.

For information on Power Link charging dispensers and other modular EVSEs in the ChargePoint Express platform, refer to the Express platform documents at [ChargePoint Product Reference Documentation](#).

Exterior Parts

The following shows an exterior view of the Express Solo.

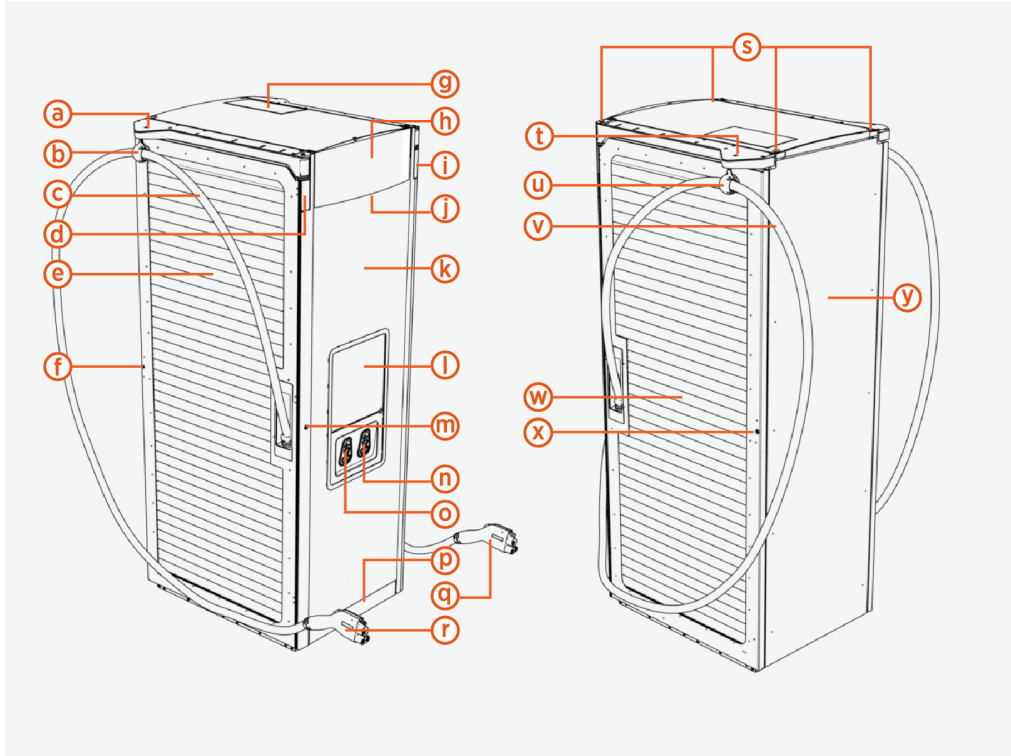

Ref	Part	Ref	Part
(a)	Cable management system, left	(n)	Holster, right
(b)	Tetherball, left	(o)	Holster, left
(c)	Charging cable, left	(p)	Bottom plate
(d)	Status LED, left	(q)	Charging connector, right
(e)	Exhaust (left) door with airflow vents	(r)	Charging connector, left
(f)	Exhaust door lock	(s)	Lifting points
(g)	Smart Antenna	(t)	Cable management system, right side
(h)	Logo plate (customizable)	(u)	Tetherball, right
(i)	Status LED, right	(v)	Charging cable, right
(j)	Area downlight (front – illumination side)	(w)	Intake (right) door with airflow vents
(k)	Display door (with customizable vinyl)	(x)	Intake door lock
(l)	Display/CCOM* assembly (display side)	(y)	Rear panel
(m)	Display door lock		

* Control and Communication Module

Cable Management System

Express Solo is available with several cable management options:

- **Fixed Tether Point** – Charging cables are suspended from fixed points on left and right sides of the charging station.

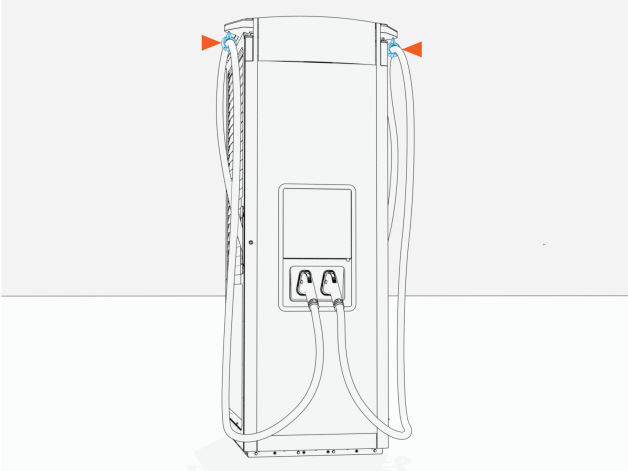

- **Swingarm Cable Management Kit (CMK)** – Moveable arms on left and right sides of the cabinet swing suspended charging cables out and forward for charging and retract cables to rest position between charges.

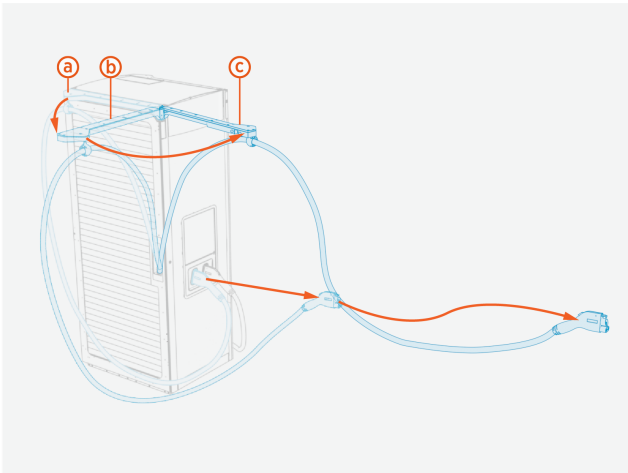

- (a) CMK retracted position
- (b) CMK half open (maximum side extended) position
- (c) CMK fully open (maximum front extended) position

- **Overhead CMK** – An extendable/retractable tetherball suspends charging cables on poles (or other vertical structure) positioned to the left and right of the station.

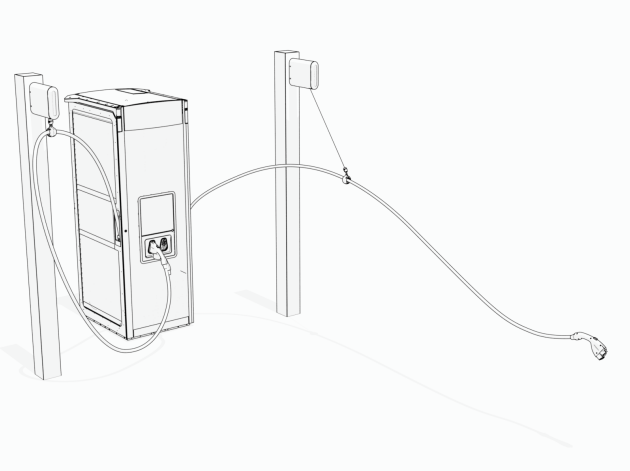

Interior Parts

The following shows a front interior view of the Express Solo.

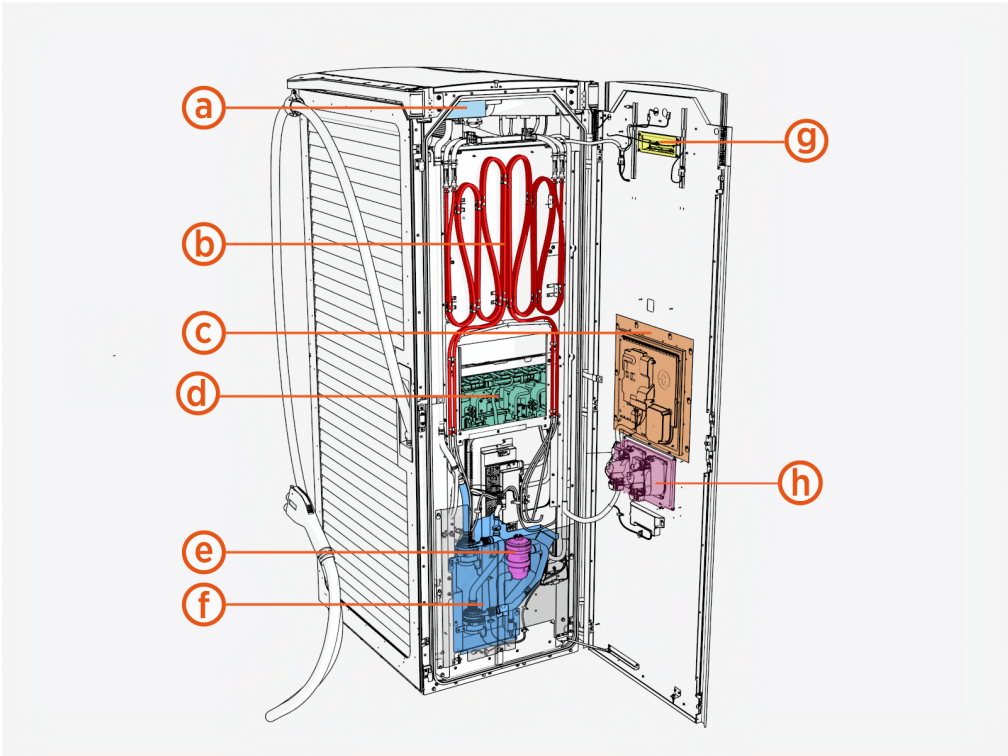

Ref	Part
(a)	Coolant reservoir
(b)	Liquid cooling system
(c)	Display/CCOM Assembly (CCOM side)

Ref	Part
(d)	Neutron modules
(e)	Ion filter
(f)	Coolant circulation pump for liquid cool charging (LCC) loop
(g)	Area downlight (rear housing)
(h)	Holsters

The following shows side interior views of the Express Solo:

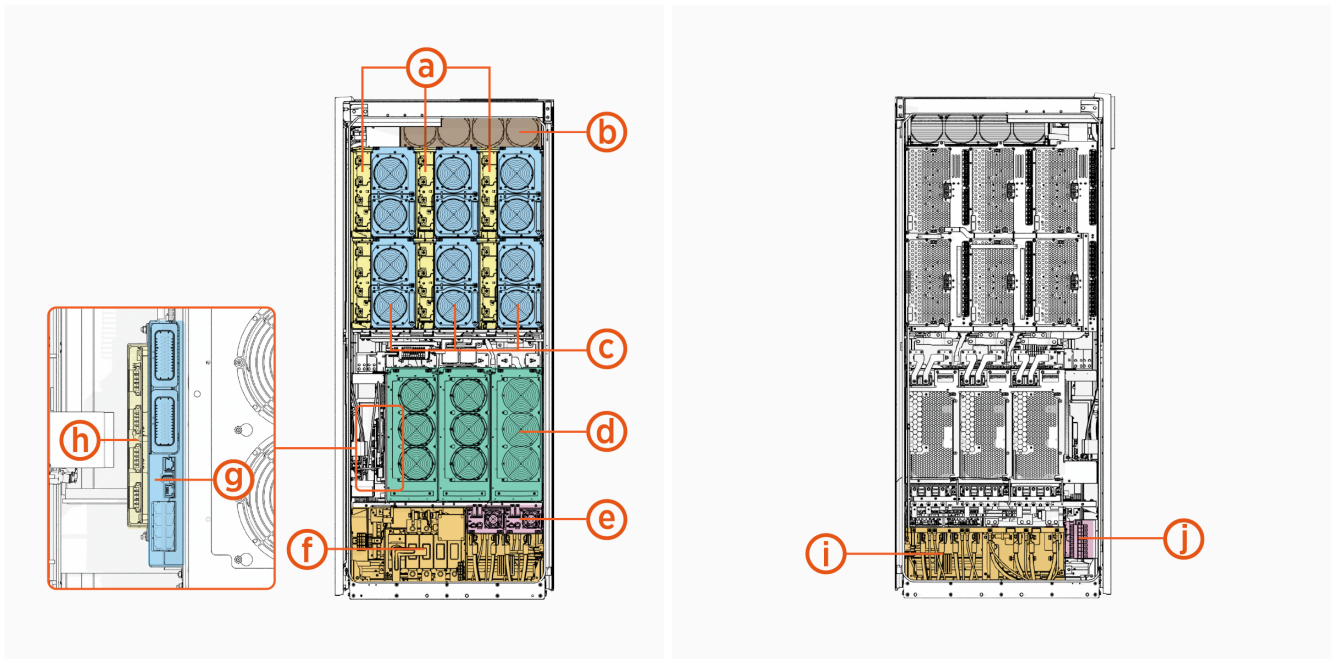

Intake (Right) Side

Exhaust (Left) Side

Ref	Part	Ref	Part
(a)	Contactor matrix	(f)	Wire terminals and bus bars, intake side
(b)	Liquid cooled charging (LCC) cable fans	(g)	Power Management Controller (PMC)
(c)	DC power modules	(h)	Safety Hub Board (SHB)
(d)	AC power modules	(i)	Wire terminals and bus bars, exhaust side
(e)	Aux power supply (AUX PS) modules	(j)	48 V DC fuse block

System Description

The Express Solo intakes 3-phase AC grid power and performs power conversion with two types of modules:

- **AC Power Module** – The AC power module converts AC input power to DC output power. Up to three modules can be installed into each Express Solo to scale total power capacity.
- **DC Power Module** – The DC power module is an isolated, bidirectional DC/DC converter that conditions power for delivery to downstream EVs.

The Express Solo has two separate DC power distribution buses, each with its own set of interfaces:

- **DC Grid Bus and DC BUS** – 480 V AC and 400 V AC Express Solo models feature a non-isolated bus called DC Grid that operates at up to 950 V (depending on region and application). These Express Solos are equipped with an interface to its DC Grid Bus, called DC BUS. Two Express Solos may be paired (configured for power sharing) by interconnecting their DC BUSES. 600 V AC Express Solo models do not support DC Grid.
- **DC Output Bus and External DC Outputs** – The DC Output Bus is an isolated DC bus (100–1000 V) that delivers regulated output power to connected EVs. Power flow from the DC Output Bus is routed through the Contactor Matrix, which outputs power across the two integrated charging cables (charging points (CPs)) and to two discrete external DC outputs designated EXT B and EXT D. Each external DC output can supply power to a single input power path of a Power Link charging dispenser.

The Express Solo is equipped with an Auxiliary Power Supply (APS) system:

- **Auxiliary Power Supply (AUX PS) Modules** – Each cabinet includes AUX PS modules that generate 48 V DC power for internal electronics and sub-assemblies within the unit.
- **48 V DC Output** – Express Solo provides two 48 V DC outputs for supplying power to connected Power Link charging dispensers.

The Express Solo features an integrated system that facilitates safe and reliable communication and control:

- **Control and Communications Module (CCOM)** – This module manages various system assemblies such as the UX hardware, display, and communication hardware (cellular). It communicates over Ethernet with external system components and manages charge sessions, user authentication, access control, and communication with ChargePoint Cloud Services.
- **Power Management Controller (PMC)** – The PMC controls power flow within the system. It communicates with the power converters and the contactor matrix to manage the delivery of power to the EV. The PMC supports Ethernet ports for communication with various components like the CCOM, external charging dispensers, and paired Express Solo cabinets to ensure seamless operation. In the event of a fault, the PMC can instruct the power converters to stop power delivery and open the contactors to isolate the power source.
- **Neutrons** – The Neutron module serves as the insulation monitoring device and meter for the charging cables. It detects isolation faults and uses a switch to signal the Safety Hub Board (SHB).
- **Contactor Matrix** – The contactor matrix receives commands from the PMC to open or close the contactors as needed.

-
- **Safety Hub Board (SHB)** – In addition to processing fault reports from the Neutron, the SHB supports four dispenser ports for performing continuous electrical isolation monitoring of connected Power Link charging dispensers. Any faults detected are reported to the PMC.



NOTE: Safety Hub monitoring is not required for all models of Power Link.
Contact ChargePoint for details.

- **Door Interlock Sensor** – Express Solo is equipped with a shunt trip relay that de-energizes the cabinet when doors are open. The PMC reads the door sensor status and shuts down power conversion if one of the doors is open. A safety panel sensor triggers the shunt trip if AC input voltage is present. This ensures the station powers down when the cabinet door is open.

System Interfaces and Sample Architecture

The following provides a high-level overview of the electrical interfaces of an Express Solo. The diagram also illustrates the interconnections required for an example architecture featuring:

- Two paired Express Solos
- An Express Solo that provides DC output power to the input power paths (A and B) of a Power Link 2000. The Power Link 2000 is equipped with two charging cables (L and R). Note that Power Link 2000 does not require Safety Hub (SH) monitoring.

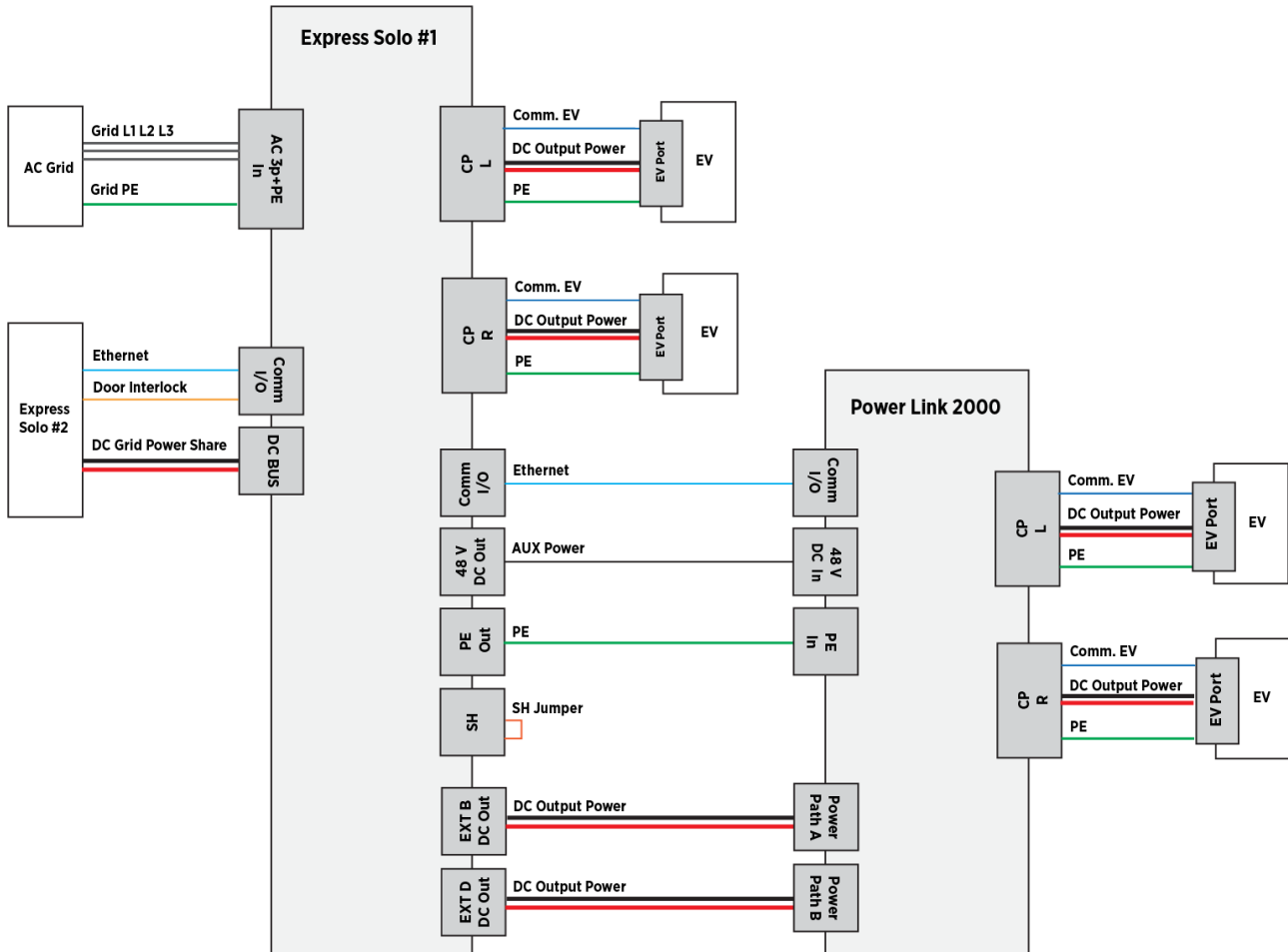

IMPORTANT: Express Solo can be configured in many different system architectures, only one of which is shown above. The actual architecture for each site will vary depending on the number of stations, the charging capacity required at each charging station, charging requirements, and other criteria. If you are a site designer, contact a ChargePoint representative for the ChargePoint-approved wiring architecture for your specific project. Systems configured with non-approved wiring between Express Solo and connected EVSEs may not function as expected. If you are an installer, see the site plan for the architecture specific to the site installation project.



Product Guides

A full suite of guides is available for Express Solo, as summarized below.

Document	Content	Primary Audiences
Datasheet	Full station specifications	Site designer, installer, and station owner
Site Design Guide	Civil, mechanical, and electrical guidelines to scope and construct the site	Site designer or engineer of record
Construction Signoff Form	Checklists used by contractors to ensure the site is correctly completed and ready for product installation	Site construction contractor
Installation Guide	Anchoring, wiring, and powering on	Installer
Operation and Maintenance Guide	Operation and preventive maintenance information	Station owner, facility manager, and technician
Service Guide	Component replacement procedures, including optional components	Service technician
Declaration of Conformity	Statement of conformity with directives	Purchasers and public

Access ChargePoint documents at [ChargePoint Product Reference Documentation](#).

Questions

For assistance, go to chargepoint.com/support and contact technical support using the appropriate region-specific number.

Site Planning and Placement **2**

This section outlines general planning and placement requirements for Express Solo sites.

Initial Site Guidelines

The site designer must perform an onsite evaluation to determine conduit and wiring requirements from the panel to the proposed charging locations, and to measure cellular signal levels and identify suitable locations for any required cellular signal-booster equipment.

If you have pre-existing infrastructure or are using your own preferred electrical contractor to prepare your site, an *Express Solo Construction Signoff Form* completed by a ChargePoint Operations and Maintenance (O&M) partner is required to certify compliance with electrical code and to ensure everything was prepared to ChargePoint specifications.

Plan for Future Charging Capacity

Designing electrical infrastructure to support current and future needs for EV charging helps avoid costly upgrades later as demand for EV charging grows.

Consider these methods to prepare a site for future charging stations in a later phase of work:

- Add extra capacity if electrical panels are being upgraded now.
- Use sub-panels as a way to shorten electrical paths.
- Maximize the conduit and conductor sizes (to product specifications) between the main electrical panel and future stations, to prevent needing to re-pull wire later.
- Below-ground wiring can be pre-staged if the correct site construction is performed in advance. Allowed terminations include a distribution unit, junction box, or plugged conduit. This eases cable pulls for future stations.
- Consider locations and spaces where it will be easy to add future stations.

System Placement

The placement of the Express Solo solution must meet the following requirements:

- Express Solo is not ATEX rated and shall not be installed in an explosive area.
- Site conditions must be compatible with the following specifications listed in the *Express Solo Datasheet*:
 - Operational altitude
 - Operating temperature
 - Operating humidity
 - Enclosure rating
- Express Solo must be installed on a level concrete surface rated for the weight of the station.



WARNING: The charging station must be installed on a level concrete base rated for the weight of the station. Asphalt cannot support the full weight of the station. Failure to install the station on a suitable surface may cause the station to tip over, resulting in death, personal injury, or property damage.

Layout considerations:

- Determine appropriate ground anchoring locations where concrete exists or can be installed.
- Consider locations where it will be easy to add future stations.
- If using conduits to pull wires, determine the best conduit layout to minimize linear conduit costs to multiple parking spaces. If possible, avoid or minimize trenching requirements, especially more costly trenching to run conduit under asphalt surfaces.
- Determine if the existing utility service and electrical panel capacity is sufficient. Identify costs for any necessary upgrades and/or a new dedicated electrical panel. ChargePoint recommends using a licensed electrician to evaluate available capacity and identify any upgrades that may be required.
- If a dedicated EV electrical panel is required, choose a panel located close to the existing electrical supply.
- Measure cellular signal levels to ensure adequate cellular coverage at the station locations. To ensure adequate signal strength in underground or enclosed parking structures, cellular repeaters may be required. For more information, see [Connectivity](#).
- ChargePoint recommends avoiding locations under trees where sap, pollen, or leaves would fall on the charging station and increase the station owner's site maintenance workload.

Guidelines for Different Parking Arrangements

- Choose adjacent parking spaces in an area with adequate lighting.
- Consider how easily drivers can find the stations they need to access.
- Check local requirements for accessibility and pathway width, sometimes called “path of travel”, to ensure that station placement does not restrict sidewalk use.
- A pad built into the head of a parking space (instead of on the sidewalk) is allowed if local code allows it compared to the minimum parking space length, and the pad meets all pad requirements listed in this document.

Cable reach

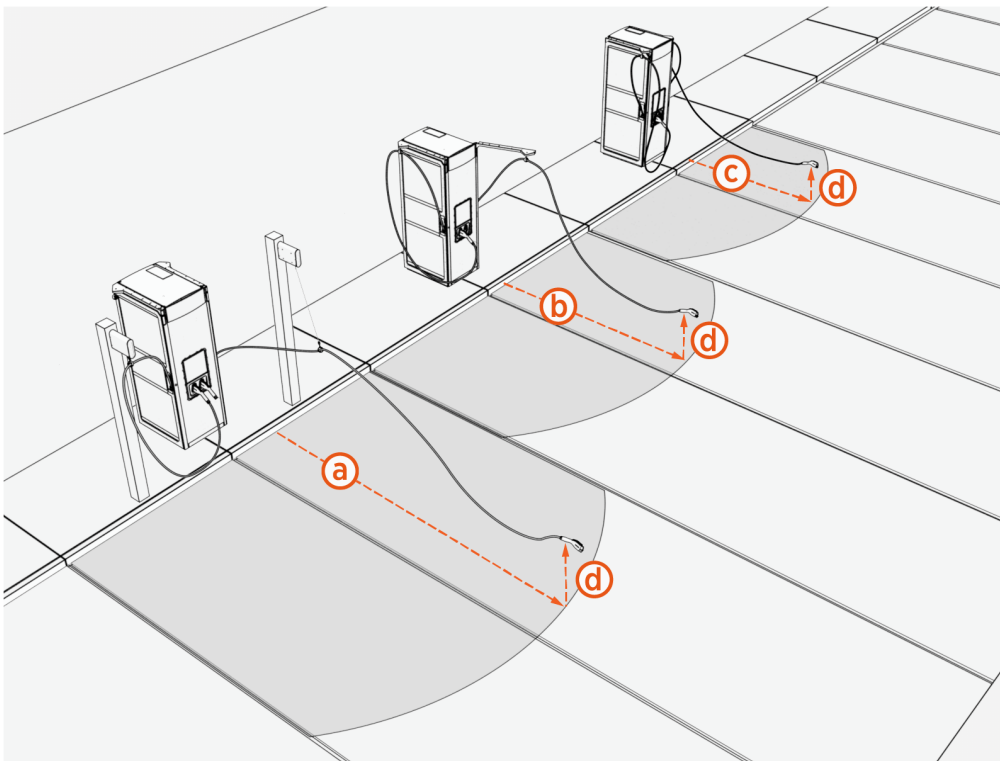

The following table provides the maximum cable reach from the station to charge port on a vehicle:



NOTE: The cable reach specifications for both the tall CMK and overhead CMK include the full extension of a tether cord from the CMKs, as depicted in the illustration above.

		Overhead CMK	Swingarm CMK	Fixed Tether Point
Cable length		7.6 m (25 ft)	5.2 m (17 ft 0.8 in)	5 m (16 ft 4.9 in)
Cable reach	Horizontal or vertical reach	Horizontal (a)	4.2 m (13 ft 9.4 in) Horizontal (b)	3 m (9 ft 10.1 in) Horizontal (c)
	Height above ground		0.6 m (2 ft) (d)	

IMPORTANT:



- Diagonal stall parking is not recommended.
- Place each Express Solo to maximize cable reach for the varied charge port locations on different EVs.

Commercial or public station placement, single or dual cable

For stall parking, ChargePoint recommends using perpendicular parking stalls that allow a vehicle to enter either front-first or rear-first, to better accommodate the varied locations of EV charge ports.



NOTE: While ChargePoint tests charging stations with a majority of upcoming vehicles, ChargePoint cannot guarantee the port locations of future vehicles and cannot warrant the configurations proposed will work for all vehicles.

The wheel stops are 900 mm (35.4 in) wide and are placed at a distance of 914.4 mm (3 ft) from the front of each stall.

This illustration depicts a charging station with a dual cable.

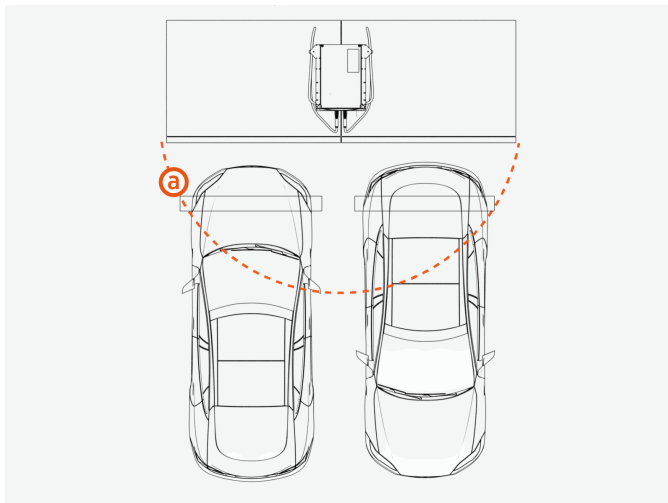

(a) Cable reach radius:

- Fixed tether point: 3 m (9 ft 10.1 in)
- Swingarm CMK: 4.2 m (13 ft 9.4 in)

The following three illustrations depict charging stations with single cables.

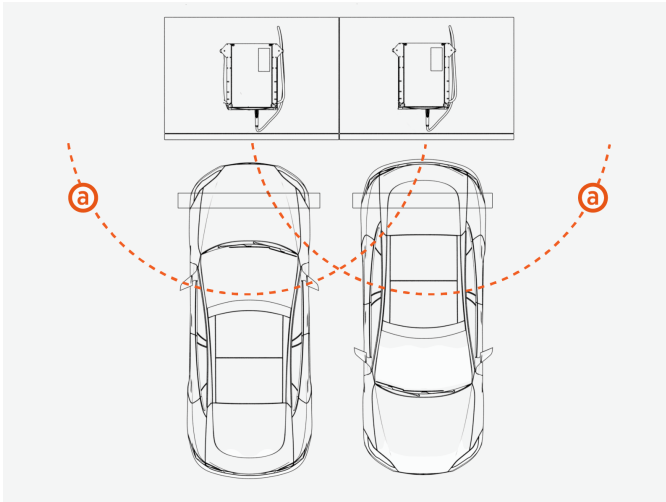

(a) Cable reach radius:

- Fixed tether point: 3 m (9 ft 10.1 in)
- Swingarm CMK: 4.2 m (13 ft 9.4 in)

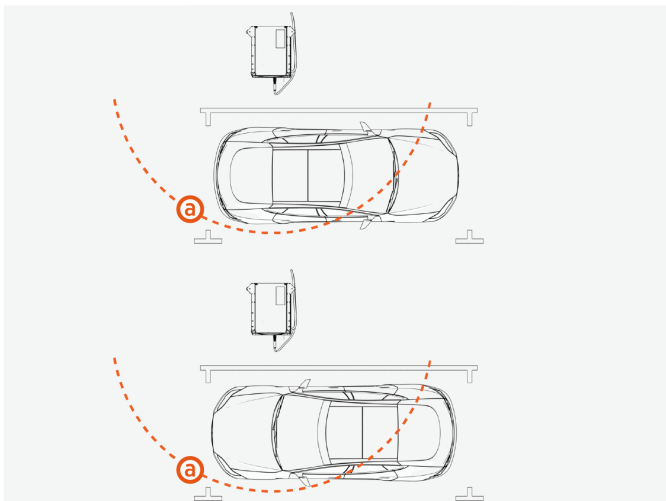

(a) Cable reach radius:

- Fixed tether point: 3 m (9 ft 10.1 in)
- Swingarm CMK: 4.2 m (13 ft 9.4 in)

Fleet Parking Arrangement

- **Stall parking (dual charge cable):** For installing dual charge cable Express Solo stations, consider placing the station in front of every other parking space. Additionally, align the overhead CMK tether with the parking stripes on either side of the charging station.

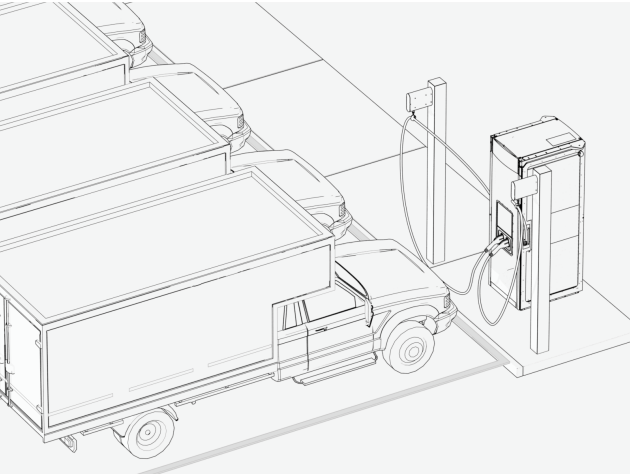
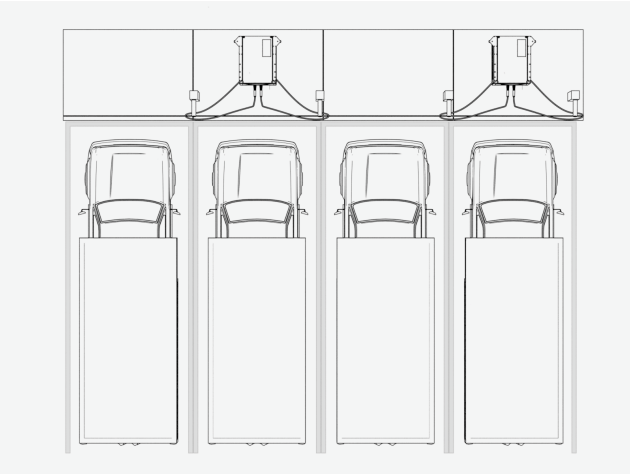

- **Stall parking (single charge cable):** Express Solos with single charging cables are always configured with the charging cable on the right side of the enclosure. Align the overhead CMK tether with the parking stall stripe adjacent to the vehicle's charging port. The illustrations below depict parking of the vehicles in relation to the charging stations, based on the side where the vehicle's charging port is located.

Vehicles with left-side charging ports :

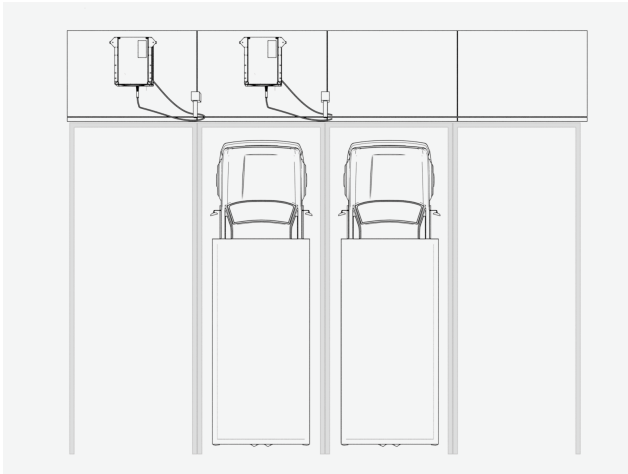

Vehicles with right-side charging ports:

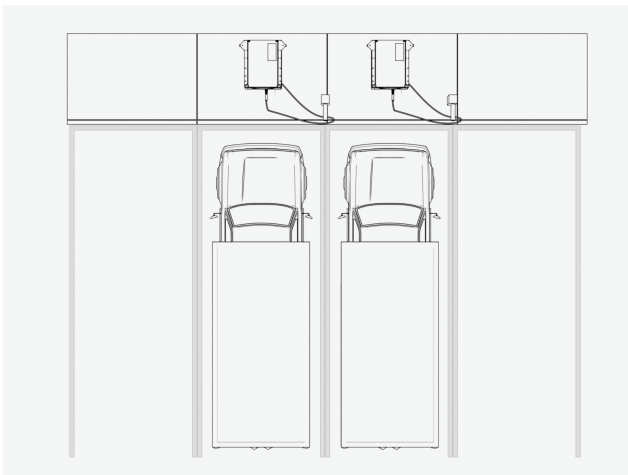

- **Island parking:** ChargePoint recommends placing a station in the center of the island facing away (station front is perpendicular to vehicles) in the same orientation. This allows the station to be accessible from both sides of the island. Swing arm CMK is not recommended for island use if vehicles are taller than the station.

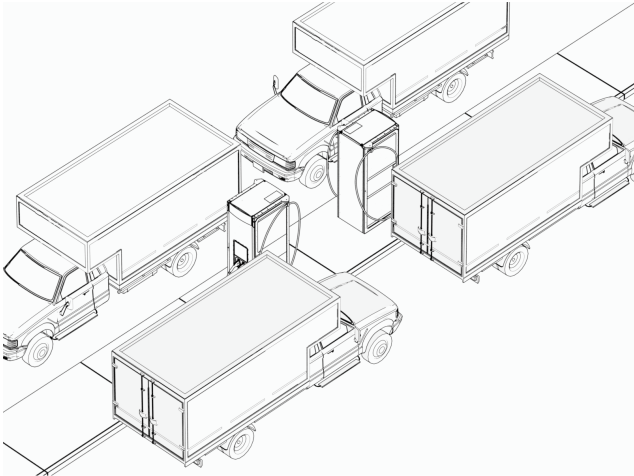
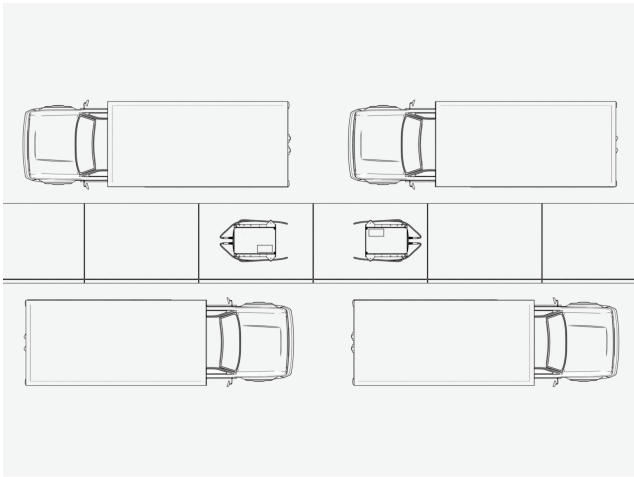

Civil and Mechanical Design 3

This section describes civil and mechanical site design guidelines for Express Solo.

Dimensions



NOTE: Images given in this section are not to scale. Measurements appear in metric units (mm), followed by imperial equivalents (inches).

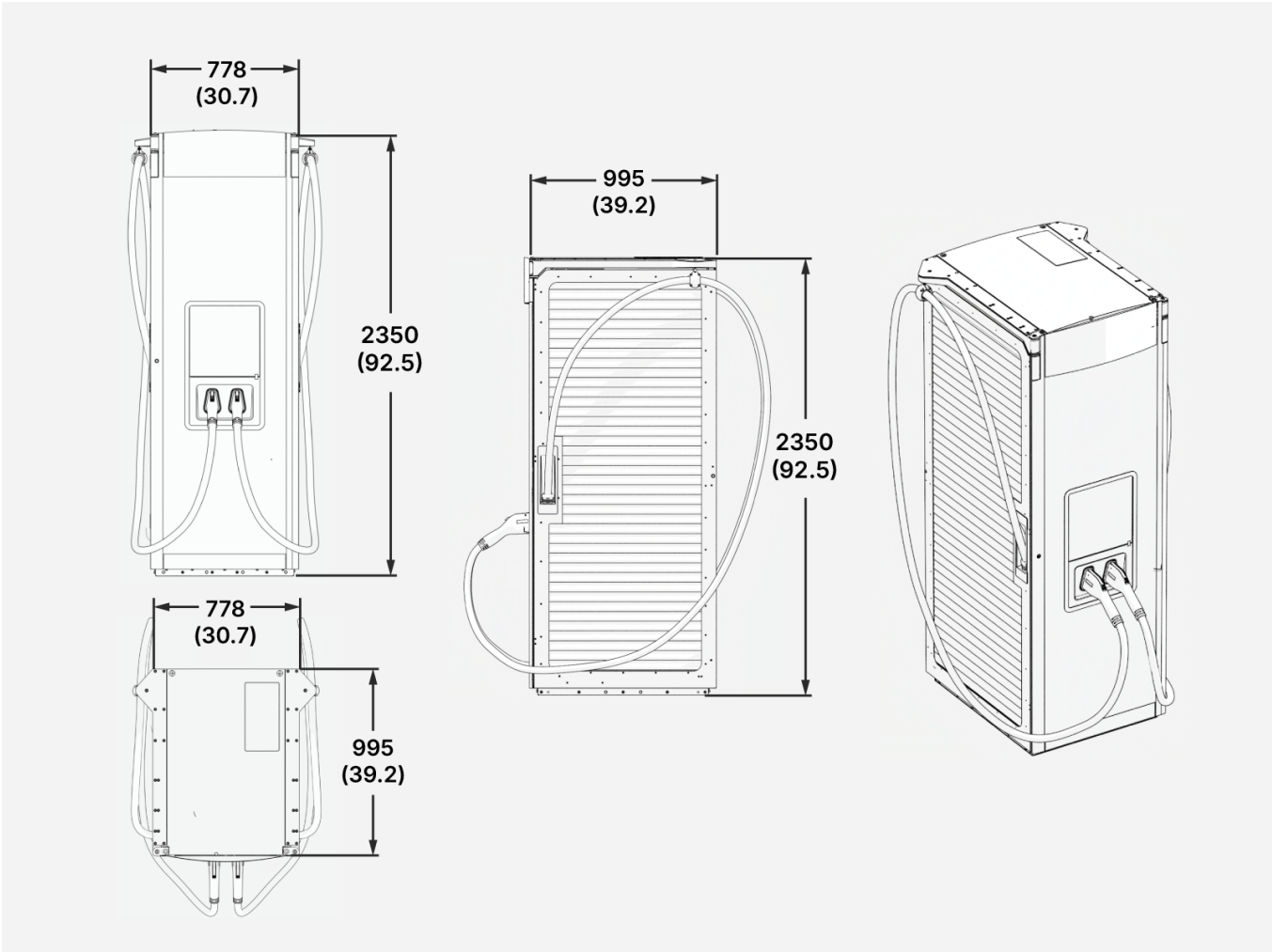

Weights

The following enables calculation of the Express Solo weight, depending on its configuration:

Component	Weight
Express Solo (fully loaded with power modules)	1300 kg (2866 lb)
AC power module	93 kg (205 lb)
DC power module	68.5 kg (151 lb)

Mount Specifications



WARNING: If not installed correctly, ChargePoint charging components may pose a crushing hazard, leading to death, personal injury, or property damage. Always use a ChargePoint-approved mounting method to install the ChargePoint charging components, as described in this section. Always install in accordance with applicable codes and standards using licensed professionals. Non-approved installation methods are performed at the risk of the contractor and void the Limited One-Year Parts Exchange Warranty.

Concrete Pad Specifications

The Express Solo must be installed on a concrete pad or engineered foundation. The concrete pad may be either newly poured or it may be an existing concrete surface.



IMPORTANT: The concrete surface must be smooth and level. If an existing concrete surface does not meet the level requirement, a localized leveling pad must be poured.

To design a site-specific new pad, submit the following parameters for a structural engineering analysis. The table consolidates all required inputs—whether provided directly here or defined elsewhere in the guide—so the structural engineer receives a complete and consistent set of values.

Parameter	Value
Weight	See Weights
Height x width	See Dimensions
Frontal area	Height * Width as given in Dimensions
Center of gravity height	1349 mm (53.1 in)
Anchor bolts size and quantity	M20 (x4)
Anchor bolts placement	See Anchor Bolts Placement

Alternatively, if installing on an existing pad, a structural engineer must:

- Inspect and approve the existing pad for use, based on the parameters listed above
- Verify the anchor bolt embedment for structural strength

For additional information on using an existing pad, see [Surface Mount](#).

Anchor Bolts Placement



NOTE: Images given in this section are not to scale. Measurements appear in metric units (mm), followed by imperial equivalents (inches).

Express Solo mounts over four anchor bolts embedded in a concrete pad with the anchor bolt pattern shown below. The image perspective is looking from the ground up at the bottom plate of the cabinet.

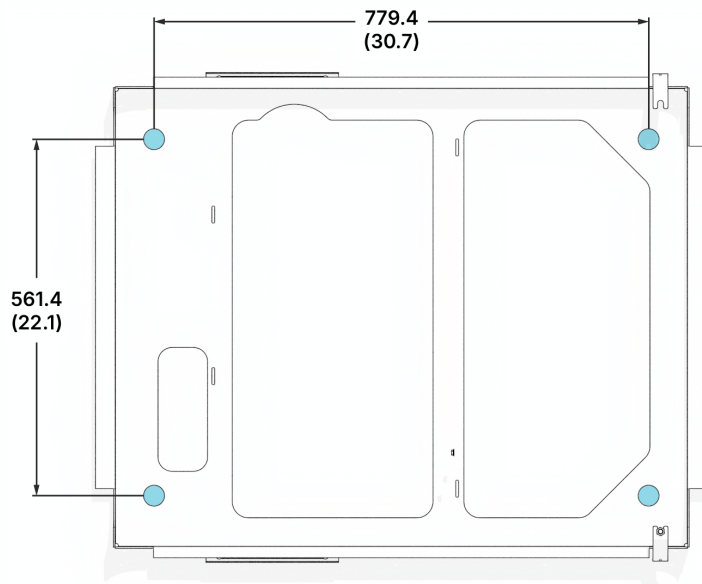

The distance from the center of each anchor bolt to its adjacent enclosure walls is 108 mm (4.25 in).

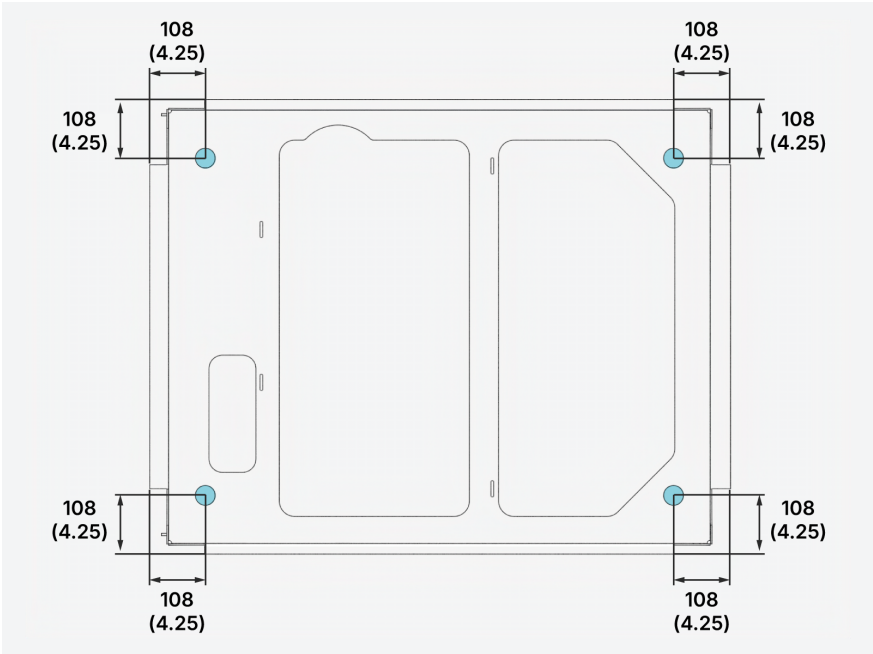

Standard Mount

The most common mounting method for the Express Solo is a new pad installation using a Concrete Mounting Template (CMT) and conduit stub-up wire entry.

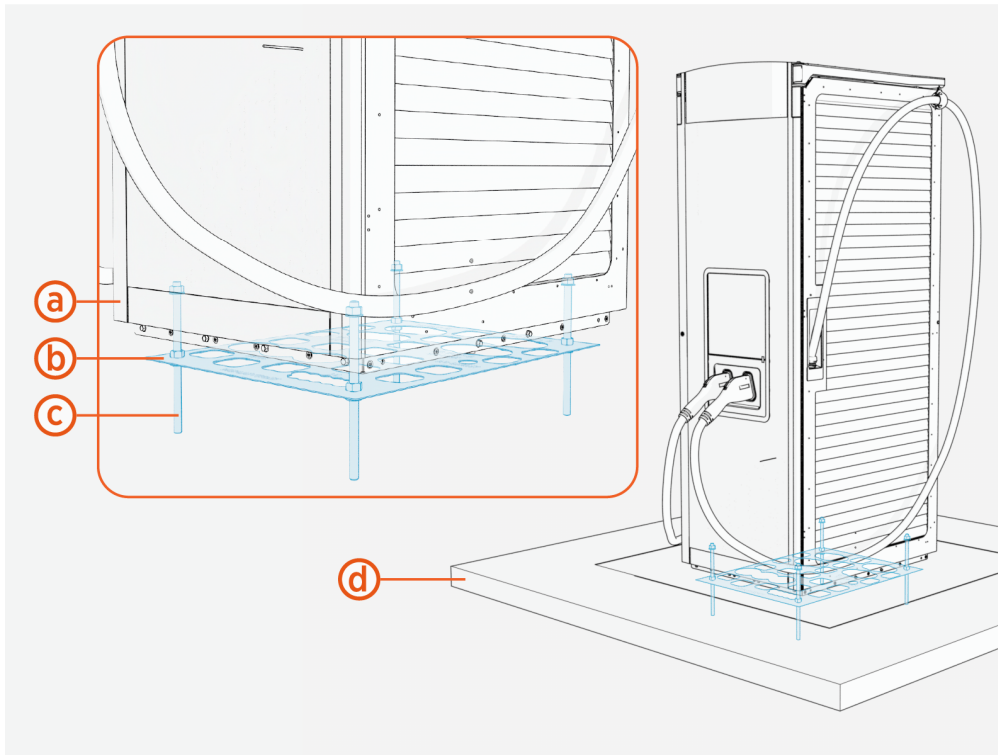

- The Express Solo pedestal (a) mounts onto four M20 anchor bolts (c) exposed 127 mm (5 in) above the concrete pad.
- The CMT (b) is embedded into a newly poured concrete pad (d) to align anchor bolts and underground stub-up wiring conduits. (Conduits are not shown in illustration.)

IMPORTANT:



- The CMT is shipped separately and must be assembled onsite before pouring the concrete pad.
- The CMT must be embedded with its top panel positioned 51 mm (2 in) below the concrete surface.

Concrete Mount Template

The concrete mount template (CMT) positions the anchor bolts and wire entry as shown below.

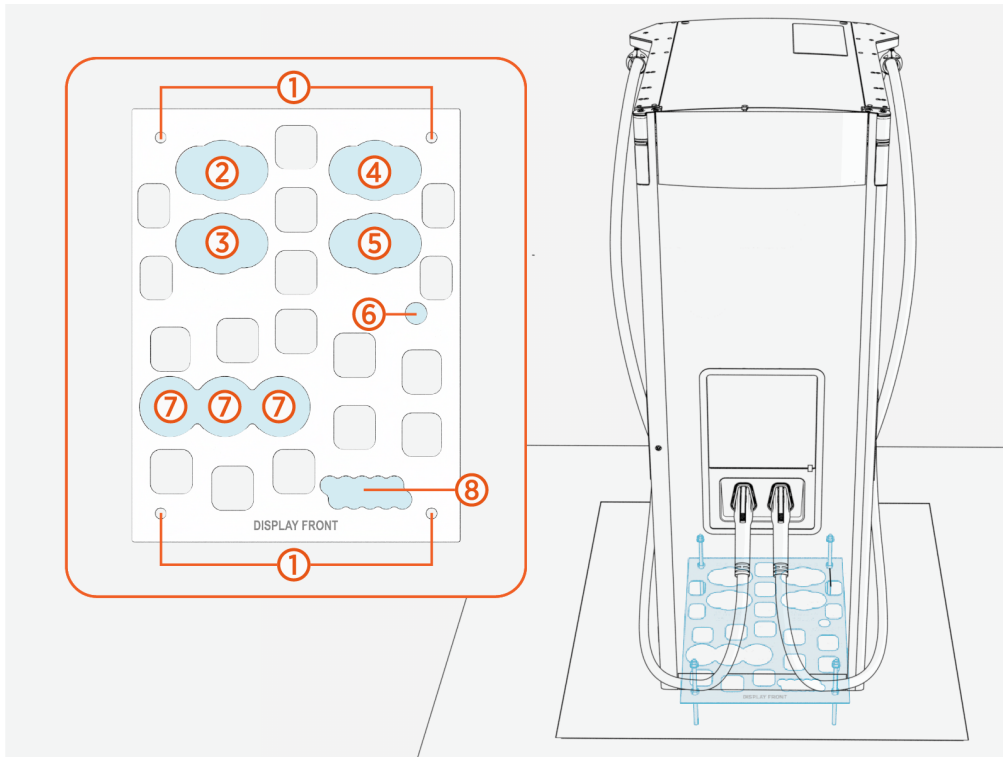

- (1) M20 anchor bolts (x4)
- (2) EXT D wires
- (3) DC BUS (exhaust side) wires
- (4) EXT B wires
- (5) DC BUS (intake side) wires
- (6) Shunt trip wires
- (7) AC input wires
- (8) 48 V DC output, Ethernet, Safety Hub, and door interlock wires

For conduit quantity and size requirements, refer to [Conduit Requirements](#).

Surface Mount

Express Solo may be installed on an existing concrete surface in accordance with the following guidelines:

- The concrete surface must be inspected and approved by a structural engineer, as described in [Existing Pad Structural Analysis Parameters](#).



IMPORTANT: Verify the anchor bolt embedment for structural strength.

- The anchor bolts must be installed in the concrete surface as follows:
 - Anchor holes are drilled into the concrete using the anchor bolt pattern given in [Anchor Bolts Placement](#). The holes are drilled to a depth so that 127 mm (5 in) of each anchor bolt is exposed above the concrete pad.
 - Anchor bolts are epoxied into the holes. Use an epoxy with a minimum bonding strength of 11.7 MPa, compressive strength of 82.7 MPa minimum, and tensile strength of 49.3 MPa minimum. Examples include Hilti HIT-RE 500 V3 (normal cure) or Hilti HIT-HY 200-A (fast cure).

NOTE:

- Epoxy is required only if embedding anchor bolts into an existing concrete pad. It is not applicable for a new concrete pour with CMT.
 - Different epoxy types have different cure times at various temperatures. Check local temperatures for the site in advance to help choose an appropriate epoxy.
- The anchor bolts must be hot dip galvanized. In coastal or other high-corrosion environments, consult a corrosion specialist to determine an appropriate bolt material and coating system.
 - Surface mounted Express Solo must utilize [surface conduit entry](#).

Surface Conduit Entry

Express Solo can be installed on a platform for surface conduit entry. [Contact ChargePoint](#) for more information.

Drainage

Ensure any site slopes, walls, or fencing do not trap water around the installation site.

Flood Plane

Express Solo is designed for a 61 mm (2.4 in) flood plane. If the site has a flood plane greater than 61 mm (2.4 in) for a 100-year flood event, consider installing the Express Solo on a raised concrete pad.



WARNING: Exposing the Express Solo to over 61 mm (2.4 in) of standing water could create an electrocution, shock, or fire hazard.

If a Express Solo has been exposed to standing water, cut power to the component and [contact ChargePoint](#) before the component is powered on.



Clearances

Clearance requirements for the Express Solo are given below. The figure shows a top-down view of the Express Solo cabinet overlaid on the CMT.

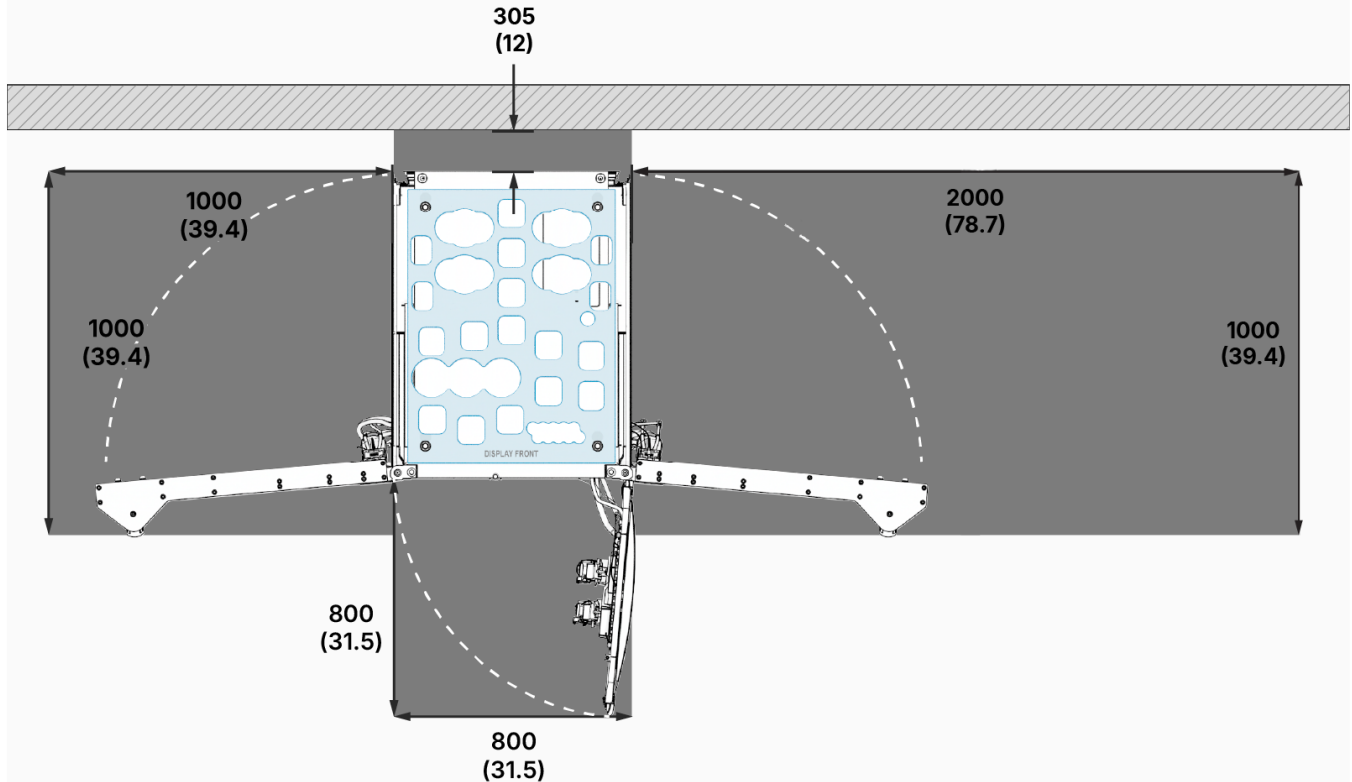

NOTE: Images given in this section are not to scale. Measurements appear in metric units (mm), followed by imperial equivalents (inches).



-  Mandatory clearance area
-  Wall, fence, or other obstruction



IMPORTANT: The ground within the defined mandatory clearance areas must be firm, stable, at grade (+/- 13 mm or 0.5 in), and free of any elevation changes. This ensures safe access when working with tools such as a module lifter, ladders, or similar equipment. Failure to maintain the required clearances or to ensure proper ground conditions may obstruct or prevent essential service operations or result in damage to the product.

Clearance requirements for two Express Solos installed back-to-back are given below.

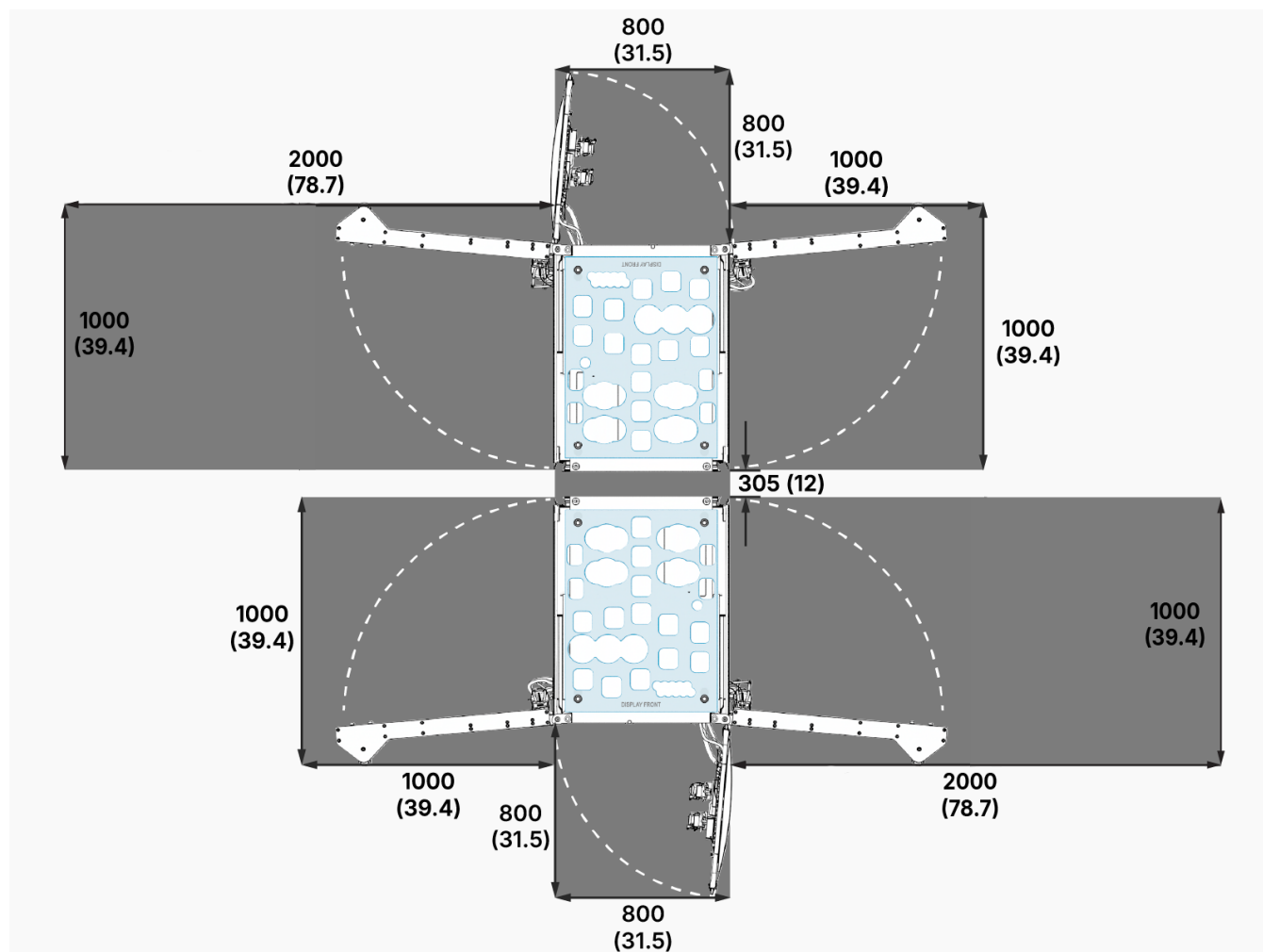

■ Mandatory clearance area

Additionally, follow the clearance guidelines below:

- The status LEDs must not be obstructed from view. See [Exterior Parts](#) for the location of the status LEDs.
- After site make-ready, the only method to confirm that clearance requirements have been met is to inspect the position of the anchor bolts. See [Anchor Bolts Placement](#) for the specific measurements between the anchor bolts and the cabinet walls.
- Check local and regional codes for any additional clearance requirements regarding safety, high voltage equipment, and accessibility requirements.
- For any questions about allowable layouts, [contact ChargePoint](#).

Bollards

Bollards are not explicitly required by ChargePoint. If applicable, ChargePoint recommends these best practices and considerations when designing bollards for the site:

- Permanent bollards must not encroach upon the clearance areas described in [Clearances](#).
- Removable bollards are allowed if service personnel have the ability to move them as needed.

Bollards and wheel stops each has advantages and disadvantages. Factors to consider include: cosmetics, usability, accessibility and vehicle types.

Wheels stops offer the following advantages:

- Clean look
- Less chance of cables getting tangled with bollards

Bollards offer the following advantages:

- Better for ADA (see [Accessibility](#))
- Larger vehicles and sites with mixed vehicle sizes that have different overhangs (trucks vs. light duty vehicles)
- More visibility while backing up

Ventilation

Intake vents are located on the right side of the Express Solo, and exhaust vents are on the left side when facing the display door. When positioning multiple Express Solos, orient intake and exhaust to avoid recirculation.

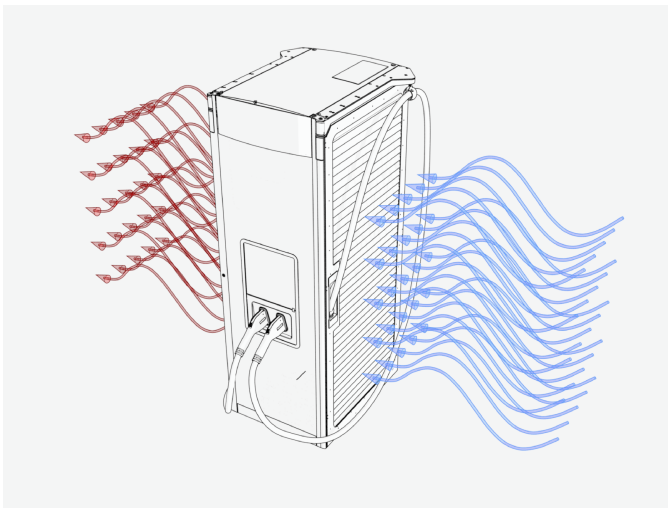

NOTE: Express Solo requires 33 kW (112,600 BTU/hr) of heat rejection.

Accessibility

Comply with regional accessibility laws, regulations, and ordinances. The Express Solo charging station must not block ramps or pathways and the height of the interactive display cannot exceed the maximum height as dictated by local laws. Do not install Express Solo on a raised concrete pad for parking spaces reserved for people with limited mobility. Express Solo meets accessibility height requirements when measured from a finished floor or ground plane.

Signage

Refer to local and regional code to design the following elements for the site:

- Any required re-stripping of parking spaces
- EV or Accessible EV signs

- EV or Accessible EV paint markings on and around the parking spaces

ChargePoint recommends posting signage indicating the maximum drive-through height for vehicles passing beneath the chargers.

Electrical Design 4

This section provides electrical design guidelines for Express Solo.

Electrical Supply Requirements

EV charging equipment operates as a continuous load, drawing high current for extended periods. Branch-circuit conductors and protective devices must therefore be sized in accordance with applicable local electrical regulations for continuous-load operation.

When planning multiple EV charging stations, it is best practice to segment non-continuous and continuous loads, with all branch circuits for EV charging on a dedicated electrical panel assembly with adequate circuit breakers. When sizing new electrical panels dedicated for EV charging, all branch circuits must support continuous load.

Express Solo is available in multiple power ratings: 350 kW, 500 kW, 525 kW

Each Express Solo requires its own circuit breaker. Recommended breaker sizing is given below. Check with local code for breaker size requirements.

Recommended breaker size for the Europe region (400 V AC):

Max. Output Power	AC Nominal Input Current Rating	Recommended breaker size
Max output power 350 kW	542 A	600 A
Max output power 500 kW	789 A	800 A
Max output power 525 kW	809 A	900 A



IMPORTANT: Express Solo has a short circuit current rating of 100 kA.

Express Solo is tested to IEC 61000-4-5, Level 5 (6 kV @ 3000 A) standards.

Disconnect and Emergency Shutoff

Express Solo ships with an AC disconnect switch for emergency shutoff. The switch is located on the intake side of the Express Solo cabinet.

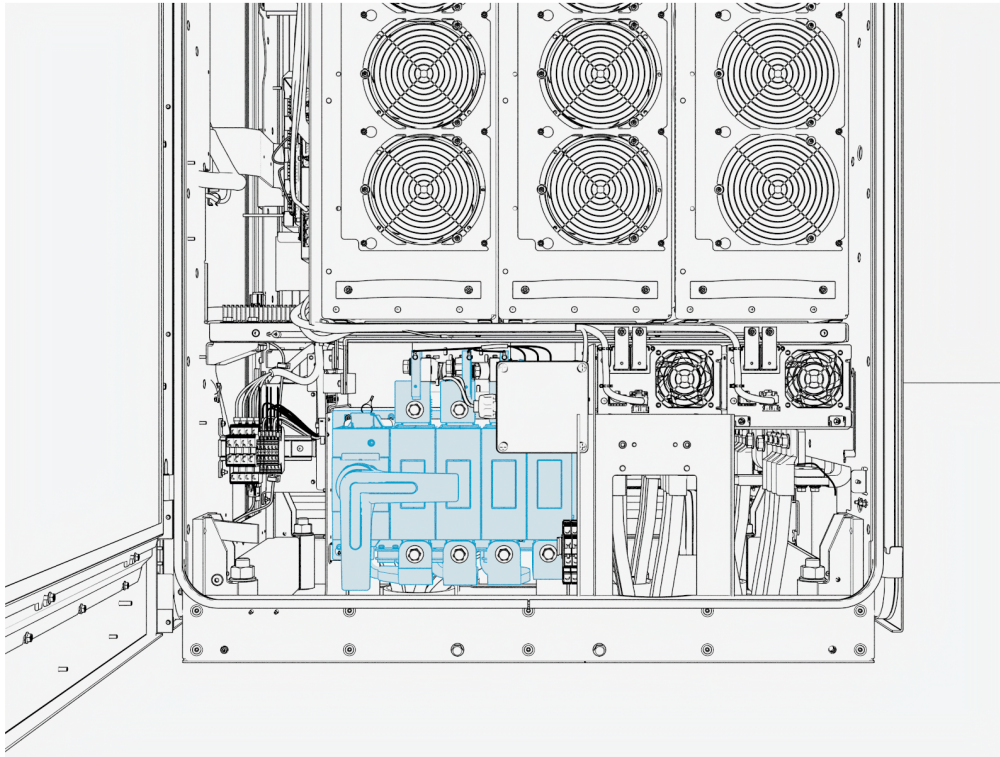

Transformer Configuration

Refer to the following table for the transformer configuration.

Parameter	Transformer Configuration
Input rating	400 V AC, 3-phase, 850 A, 50 Hz
Electrical service configuration	400 V AC 3-phase grounded WYE (Y) configuration 400 V AC 3-phase Delta (D) configuration (corner-grounded Delta transformer) is not acceptable
Product connection	Express Solo must be connected to L1, L2, and L3 (neutral not required)

Shunt Trip Wiring (optional)

Express Solo provides a set of unpowered (dry) contacts to connect to an optional shunt trip device. These contacts are rated to 240 VAC and 6 amps.

Wiring sections to and from Express Solo are deactivated when unsafe conditions are detected, such as unintended cover panel removal. A breaker reset is required any time the shunt trip is activated.

If installed, each Express Solo must be wired to the shunt trip unit of its own upstream circuit breaker. Upstream AC power must be shut off at the panel to remove shock risk inside the Express Solo. All shunt trip behavior is already hard-coded into the Express Solo and has no programmable variables.

Emergency stop devices are governed by local and regional codes and may be required in some sites. If one is required by code or by the site, confirm specifications with your ChargePoint representative.

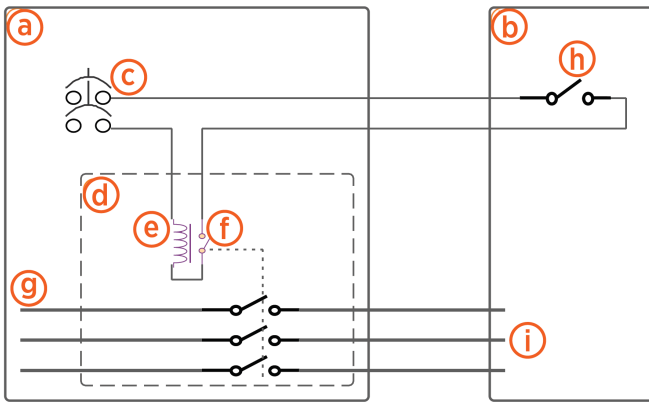

- (a) Electrical panel
- (b) Express Solo
- (c) Control voltage supply, maximum 240 VAC
- (d) Shunt trip circuit breaker
- (e) Shunt trip coil
- (f) Auxiliary contacts (closed when main contacts are closed)
- (g) 3-phase AC main
- (h) Express Solo shunt trip contacts, Normally Open (inside the auxiliary power supply, accessible on field wiring terminal block)
- (i) 3-phase Express Solo AC input

Grounding Requirements

- Express Solo is categorized a class 1 equipment and therefore its chassis must be connected to a grounded, conductive, and permanent wiring system in accordance with IEC 60364 and/or applicable national standards.
- Provide a protective earth (PE) conductor sized according to local regulations.
- Express Solo provides an isolated DC output. The DC positive and negative conductors must not be bonded to ground or protective earth. Grounding requirements apply to the equipment chassis only.
- Express Solo is compatible with standard European earthing arrangements, including TN-S, TN-C-S, and TT systems. Installers must follow local code requirements for earthing and bonding.



NOTE: The leakage current from Express Solo to protective earth conductor can reach up to 200 mA.

Soft Shutdown

The soft shutdown function is an optional feature that can be installed as a way to stop a charge session on an Express Solo. It is not meant to safely service the Express Solo or take the place of an AC disconnect switch.

To use this feature, the installer must select and mount a physical soft shutdown switch (one per Express Solo) with the following specifications:

- Building wire rated to 600 V and suitable for the installation environment (e.g., dry, damp, or wet locations)
- Normally Open (NO) configuration
- Switch current of 2 mA
- Switch voltage of 48 V
- Gold contacts suggested

When creating the site drawings, consider where any soft shutdown switches should be positioned. If applicable, consider disability and accessibility regulations for your region when choosing switch locations.



NOTE: Soft shutdown switch requires a dedicated wire conduit. For more information, refer to [Standard Wire Entry Wiring Requirements](#).

When the switch is closed, the Express Solo software ends the current charging session with a normal stop, then opens DC contactors in the Express Solo. The station stays in this state regardless of station power, not allowing operation. Only a service technician can place the Express Solo back into service after the switch is reset to Open.



WARNING: The external DC output wires from the Express Solo could still be energized with the switch closed.

Hardwire Ethernet

As an option, Express Solo supports hardwire Ethernet connection to an external network server. The connection requires a conduit for the Ethernet cable, which must be run from the customer server or network equipment directly to Express Solo. The connection is installed in only one Express Solo within an Express cluster, providing network connection for every node in the cluster

Safety Hub

Safety Hub is an Express Solo feature that provides continuous electrical-isolation monitoring to enhance system safety. When required, Safety Hub uses a dedicated twisted-pair connection routed from the Express Solo Safety Hub Board to each associated Power Link. These conductors may share the same conduit as the 48 V DC and Ethernet wires serving the Power Links.

Safety Hub wiring requirements vary by Power Link model. Depending on the specific Power Link used in the installation, one of the following configurations will apply:

- Some Power Link models require a direct Safety Hub twisted-pair connection between the Express Solo Safety Hub Board and the Power Link.
- Other Power Link models do not require a Safety Hub wire connection. For these models, a jumper wire must be installed on the Express Solo Safety Hub Board instead of running twisted-pair wiring to the Power Link. This jumper is supplied with the Power Link and does not need to be sourced separately. Installation details are provided in the *Express Solo Installation Guide*.

Because the wiring requirement depends on the exact Power Link model—and the models are identified by product part number—[contact ChargePoint](#) to determine whether your project requires a Safety Hub twisted-pair connection or a jumper installation.

Wiring and Conduit Requirements

Refer to the *Express Solo Datasheet* at [ChargePoint Product Reference Documentation](#) for full product specifications.

Ensure that the installation location is equipped with service wiring that support the station's power requirements.

Conduit and wire size are determined based on current. Service wiring in conduit or armored cable must be run as required to comply with local electrical codes. Consult national and local codes or a project engineer to determine the grade, quality, and size of the conduit or cable.

NOTE:



- All wiring and conduit is supplied by the contractor unless otherwise indicated.
- For V2G and energy storage applications, [contact ChargePoint](#) for wire and conduit requirements.

Wire Run Lengths

- The maximum total external DC output wire run length from an Express Solo to a paired EVSE (such as a Power Link 2000 or another Express Solo) must not exceed 200 m (656 ft). Refer to the cluster configuration provided by ChargePoint for interconnect details.
- 48 V DC wire and Ethernet run length between Express Solo and any Power Link must not exceed 200 m (656 ft).
- At minimum, there must be one 48 V DC wire pair connecting from the Express Solo to each Power Link. If the distance between the Express Solo and a Power Link exceeds 100 m (328 ft), then two 48 V DC wire pairs must be run to compensate for voltage drop.
- The maximum wire run length between an Express Solo and an external network connection is 200 m (656 ft).

Ethernet Requirements

- For Ethernet communications between any two nodes (for example, between an Express Solo and a Power Link) or to an external network connection:
 - Distances up to 100 m (328 ft) must use outdoor-rated Cat6 Shielded Twisted Pair (STP) cable. Lesser grades of cable do not provide the required noise immunity.
 - Distances between 100 m (328 ft) and 200 m (656 ft) must use Paige OSP Shielded GameChanger cable (see paigedatacom.com/gamechanger) or other extended-reach cable rated for 200 m (656 ft).
- An Ethernet cable connecting between an Express Solo and a Power Link must have the shield terminated at the Express Solo end of the cable, not at the Power Link end.

- For an Ethernet cable connecting between two Express Solos, terminate the shield at only one end of the cable. The Express Solo with the terminated cable end is designated as the main unit within the cluster.

Conduit Requirements

In regions that use conduits, wire conduits may enter Express Solo through a [Concrete Mount Template](#) or through a skid via conduit stub-ups. In regions that do not use conduits and/or use armored cables, the cables may be laid per the conduit layout defined by the CMT.

If using conduits:

- Conduits must be sealed to maintain a Pollution Degree 2 environment.
- Conduits must not have bell ends. Conduits with bell ends may interfere with tolerances inside the Express Solo.
- If using conduit stub-ups (ie., not using surface conduit entry), conduits must stub-up 13–25 mm (0.5–1 in) above the mounting surface.

Below is a sample depiction of wire entry via conduit stub-ups.



IMPORTANT: Conduit and wire size/quantity are shown for illustrative purposes only. The actual quantity and size of conduits and wires for your specific site may vary and shall depend on site specific requirements.

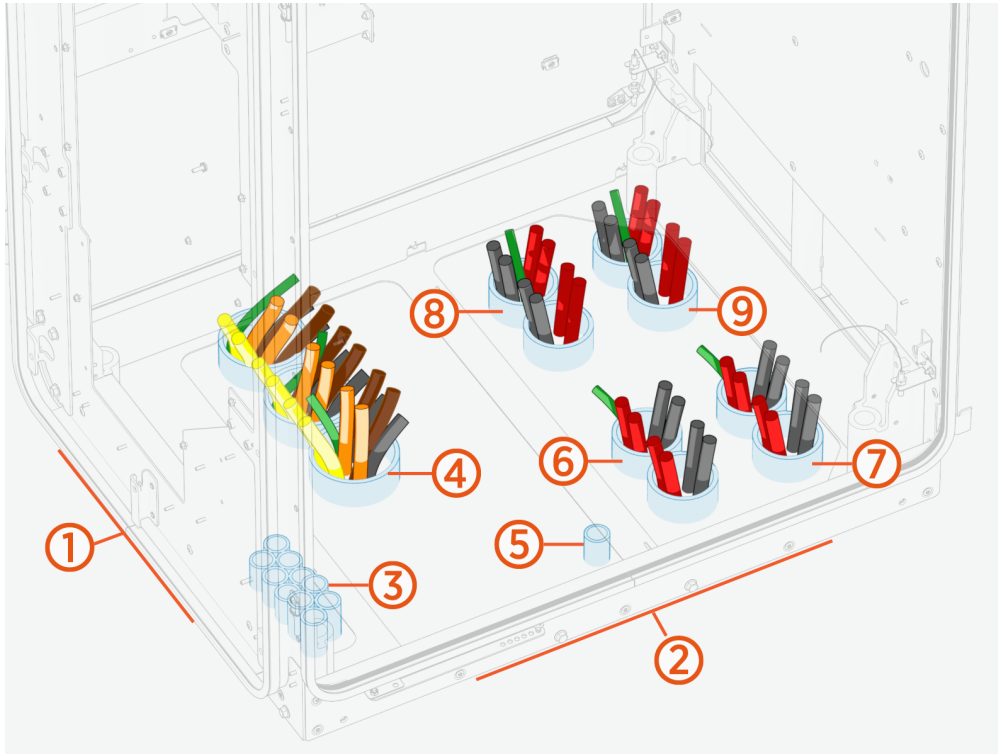

- (1) Cabinet front side
- (2) Cabinet intake (right) side
- (3) 48 V DC, Ethernet, Safety Hub, and door interlock
- (4) AC input
- (5) Shunt trip
- (6) DC BUS (intake side)
- (7) EXT B
- (8) DC BUS (exhaust side)
- (9) EXT D



IMPORTANT: The following table provides the maximum size and quantity of conduits that can be installed on Express Solo configured for standard wire entry. The actual conduit size and quantity must be chosen based on site specific wiring requirements. The outer diameter of the conduits must not exceed the maximum trade size specifications listed below.

Conduits For	Conduit Quantity x Trade Size
AC input	3 x 103 mm max.
DC BUS: <ul style="list-style-type: none">• DC BUS (intake side)• DC BUS (exhaust side)	1 x 103 mm max. per side or 2 x 78 mm max. per side
External DC output: <ul style="list-style-type: none">• EXT B• EXT D	1 x 103 mm max. per output or 2 x 78 mm max. per output
48 V DC, Ethernet, and Safety Hub*	1 x 27 mm to each Power Link 1 inch size conduit is required. The quantity of conduits will depend on the configuration.
Ethernet and door interlock**	1 x 27 mm
Optional Features (Soft shutdown switch, shunt trip, hardwire Ethernet)	1 x 21 mm max. per feature

**48 V DC, Ethernet, and Safety Hub wires travel in the same conduit when connecting Express Solo to a Power Link. Safety Hub wires are required for only for certain models of Power Link. [Contact ChargePoint](#) to determine if Safety Hub wiring is required for your specific project.*

***Ethernet and door interlock sensor wires travel in the same conduit when pairing an Express Solo to another Express Solo.*

Wire Terminal and Bus Bar Locations

The following identifies the wire terminals and bus bars accessible from the intake side (right side) of Express Solo. (Safety shields are hidden from view.)

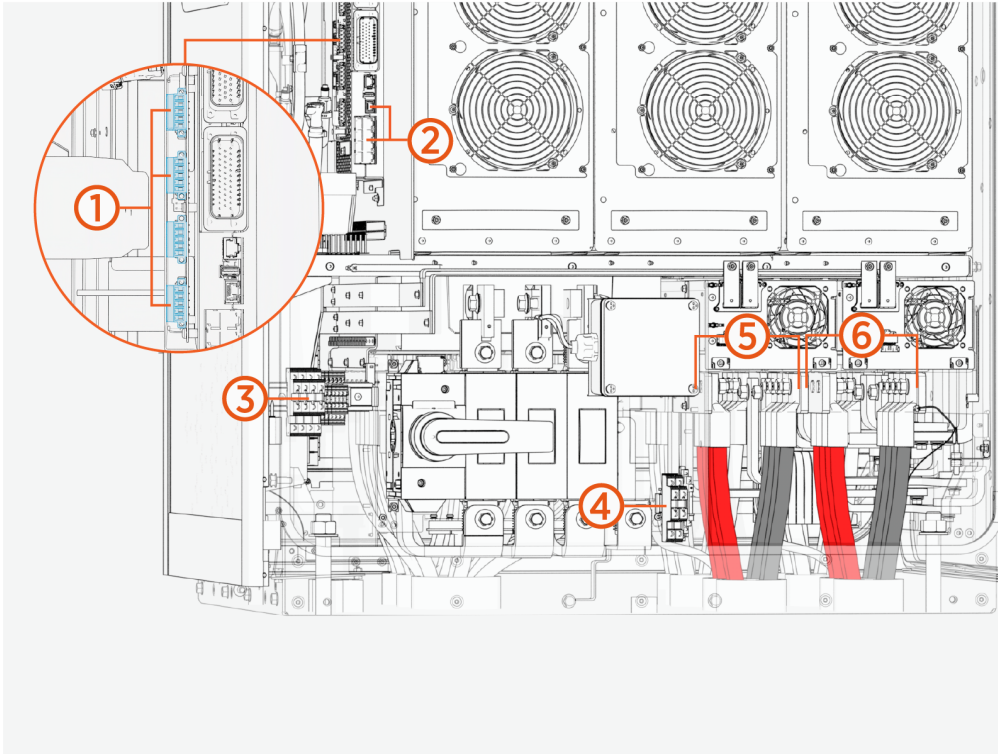

Ref	Part
(1)	Safety Hub ports
(2)	Ethernet ports
(3)	DC terminal block for 48 V DC, soft shutdown switch, door interlock sensor wires
(4)	Shunt trip terminals
(5)	DC BUS (intake side) bus bars
(6)	EXT B bus bars

The following identifies the wire terminals and bus bars accessible from the exhaust side (left side) of Express Solo. (Safety shields are hidden from view.)

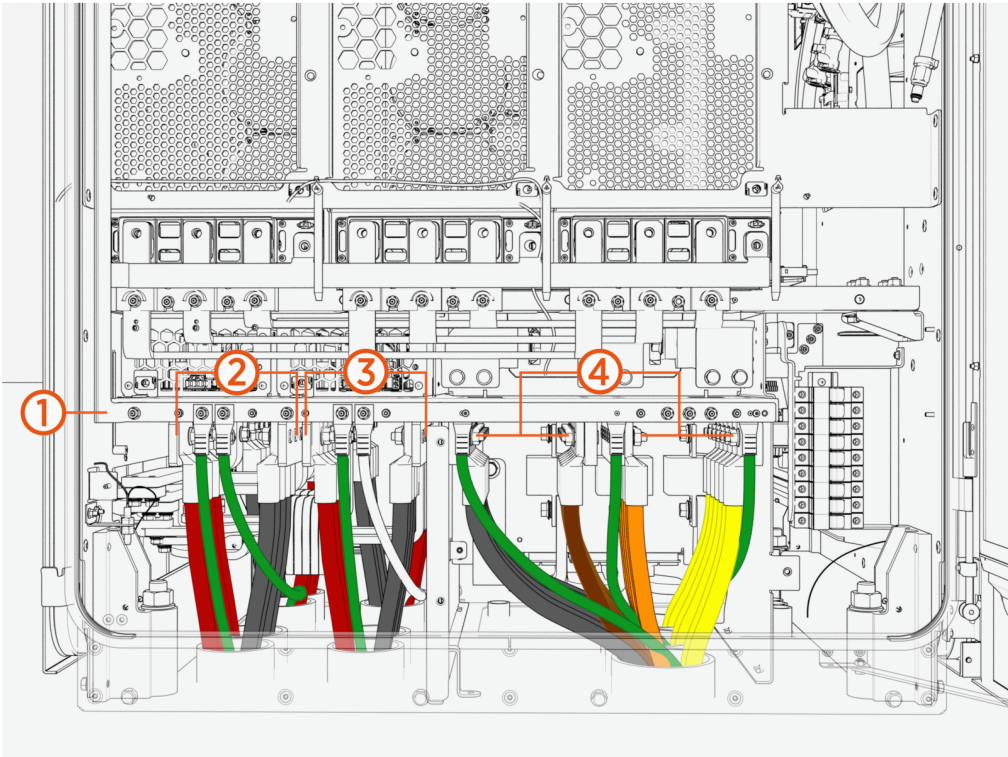

Ref	Part
(1)	Ground bar (with wire landing studs)
(2)	EXT D bus bars
(3)	DC BUS (exhaust side) bus bars
(4)	AC input (L1, L2, L3) and Neutral bus bars

Wire Specifications

IMPORTANT: For AC input and external DC output (EXT B, EXT D) and DC BUS high current conductors, use copper or aluminum wires rated for 90 °C (194 °F).

- AC input conductors must be installed following international and/or national wiring codes such as IEC 60364 and be suitable for the installation environment (e.g., dry, damp, or wet locations).
- External DC output and DC BUS conductors must use insulation suitable for at least 1000 V DC.
- Express Solo is available in two factory configurations: with a Neutral landing or without one. A Neutral connection is not required for standard charging applications. However, some Vehicle-to-Grid (V2G) systems rely on phase-to-neutral voltage measurements for control functions. When planning a V2G deployment, [contact ChargePoint](#) to ensure the correct Express Solo configuration is selected.
- For 48 V DC, shunt trip function, Safety Hub, and door interlock wiring, use copper conductors only. Ensure the wire type is selected for suitability for the installation environment (e.g., dry, damp, or wet locations).
- Use shunt trip wiring that has a voltage rating equal to the voltage rating of the AC input wires selected for the site.
- For Safety Hub and door interlock wires, use twisted wires with voltage rating equal to the voltage rating of the AC input wires selected for the site.
- All landing bus bars are nickel-plated. Use the proper type of lug based on the conductor and bus bar material.
- When using aluminum conductors, ChargePoint recommends applying an appropriate antioxidant compound when terminating into tin , nickel , or silver plated lugs, where required by local code or specified by the lug manufacturer.



IMPORTANT:



After pulling of wires, all AC input and external DC output wires must undergo insulation testing as outlined in the *High Voltage Wire Insulation Resistance Test Field Guide*.

IMPORTANT: Following are wire specifications for Express Solo, including the maximum quantity and size that the wire terminals can accommodate. All sizing assumes a maximum ambient temperature of 50 °C (122 °F). Where the maximum wire size is listed, the actual wire quantity and size must be chosen based on site-specific wiring requirements and in accordance with the maximum allowed conduit filling rate per local code.



Wire	Quantity	Size	Termination
AC Input	Max. 18 wires (six per phase)	Size based on max. current, <u>max conduit size</u> , and 200 mm wire bending space	Lug: Compression lug; short barrel and tongue with single hole sized for M12 stud Max. tongue width: 36 mm (1.3 in).
AC Ground (PE)	Max. 3 wires (1 per AC conduit)	Refer to local code for size	Lug: Short barrel and tongue with single hole sized for M6 stud
DC BUS: DC BUS (intake side) DC BUS (exhaust side)	Max. 8 wires per side (four per pole)	Size based on 1000 A max. current, <u>max conduit size</u> , and 200 mm wire bending space	Lug: Compression lug; short barrel and tongue with single hole sized for M12 stud. Max. tongue width: 36 mm (1.3 in).
External DC Outputs: EXT B EXT D	Max. 8 wires per output (four per pole)	Size based on max. current, <u>max conduit size</u> , and 200 mm wire bending space	Lug: Compression lug; short barrel and tongue with single hole sized for M12 stud. Max. tongue width: 36 mm (1.3 in).
High power ground	Max. 2 wires per interface (1 per interface conduit)	Refer to local code for size	Lug: Short barrel and tongue with single hole sized for M6 stud.
48 V DC output	Max 4 wires per Power Link (2 wire pairs; each pair has one wire per pole)	16 mm ²	Stripped wire end
Ethernet	Max. 3 cables 1 per Power Link 1 for hardwire Ethernet (if needed)	Outdoor-rated Cat6 STP*	RJ45 connector, shielded
Door interlock sensor	2 wires	1.5 mm ²	Stripped wire end
Safety Hub	2 wires per Power Link**	2.5 mm ²	Stripped wire end
Soft shutdown switch	2 wires	2.5 mm ²	Stripped wire end
Shunt trip	2 wires	2.5 mm ²	Stripped wire end

*The required Ethernet cable type depends upon the cable run length. See [Ethernet Requirements](#).

**Safety Hub is not required for all models of Power Link. [Contact ChargePoint](#) for details.



IMPORTANT: The wire specifications above reflect what is supported by the Express Solo. When connecting to a Power Link charging dispenser, the actual wire gauges and quantities may be limited by the Power Link. Refer to the *Express Power Link Site Design Guide* for details.

For AC input, Express Solo allows a maximum of 18 total current carrying conductors. If utilizing this wiring configuration, install spreader bars at the breaker or transformer to split the outputs across the high number of conductors.

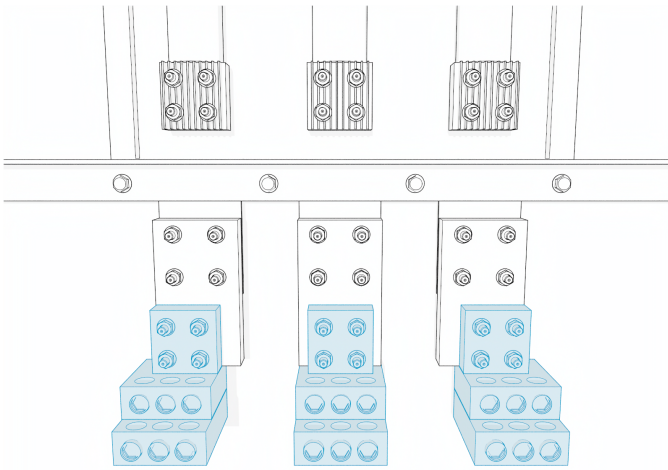

Connectivity 5

A consistently strong cellular signal is needed before installers can activate the vehicle charging station. Weak or sporadic signal can affect crucial aspects of the charging station, including:

- Accuracy in reporting
- Ability for drivers to use the mobile app
- Ability for customer support to troubleshoot problems
- Support for advanced features such as Power Management or Waitlist

A strong signal is also required for the ChargePoint Assure maintenance and management programs.

ChargePoint stations use cellular data connections to reach ChargePoint Cloud Services. This allows secure, PCI-compliant data connections without requiring any other form of internet connectivity at an install site or imposing additional network management responsibilities on a site host.

Each station has its own cellular connection.

Signal Strength and Quality

You must use a cellular signal detection device (such as a Siretta Snyder LTE or equivalent) to take signal strength readings at the exact proposed mounting location of the charging station. If the charging station does not have its own cellular connection, take the signal strength reading at the proposed mounting location of the gateway station.

In Europe, ChargePoint products all support LTE bands 1, 3, 7, 8, and 20. 900 and 1800 MHz are also supported for 2G fallback. Partners vary by country.

You must test the LTE signal strength at the proposed mounting location of every station and ensure the location meets the minimum RSRQ at -12.5 dB or better, for RSRP measured at -90 dBm or better. Refer to the graph for acceptable combinations.



NOTE: Cellular signal strength is measured in dBm, a logarithmic unit expressed as a negative number. Because dBm values are negative, a value closer to zero indicates a stronger signal. For example, -70 dBm represents a stronger signal than -85 dBm, while -90 dBm indicates a weaker signal than both.

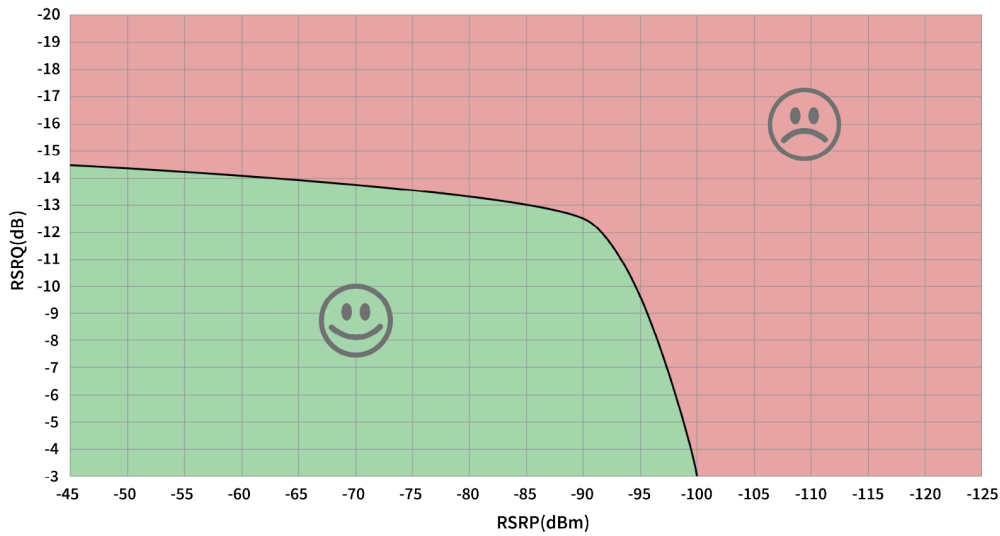

If the signal strength is weaker than this, take cellular readings at the location where any cellular signal booster antennas will be installed. Ensure enough signal exists for that repeater model. Install repeaters to boost the strength of the cellular signals. Repeaters are often required when installing charging stations in an underground garage or enclosed parking structure.

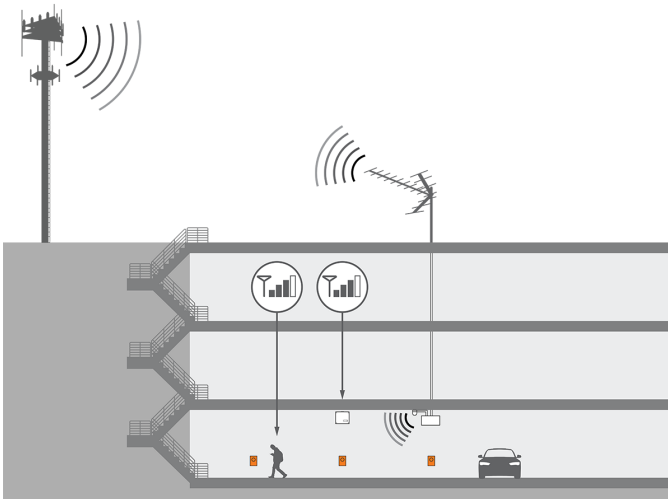
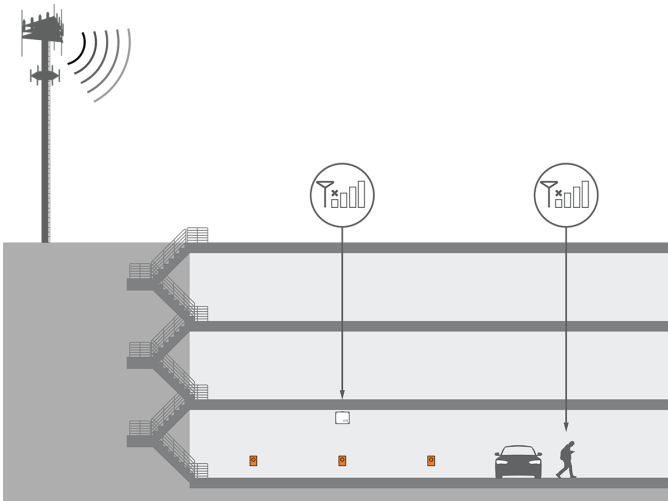

For other regions, or if the site does not have strong signal on these bands, contact your ChargePoint representative for additional solutions.

ChargePoint strongly recommends a consultation with a cellular connectivity specialist before all installations. A consultation can verify:

- Service with a supported carrier on a supported LTE band
- Available signal and local noise levels on applicable bands
- Site changes to correctly meet your needs, both for station bandwidth and other phone coverage for customer or tenant satisfaction

Repeaters

Some sites require repeaters to ensure strong signal to all stations. If a repeater is required, look for a model with these features:

- Specifically LTE-compatible on the listed bands
- Multi-carrier
- Multi-band
- Not already dedicated to FirstNet or other first responder-specific networks
- Auto-gain recommended



NOTE: Do not rely on readings taken with a cell phone when conducting site surveys. Many signal boosters and network extenders may not be compatible with ChargePoint hardware, including certain types of Distributed Antenna Systems (DAS), micro/nano/pico/femto-cells, and carrier- or band-specific signal boosters.

Repeaters are not allowed in France. Contact the French service provider for more information.

Limited Warranty Information and Disclaimer

The Limited Warranty you received with your charging station is subject to certain exceptions and exclusions. For example, your use of, installation of, or modification to, the ChargePoint® charging station in a manner in which the ChargePoint® charging station is not intended to be used or modified will void the limited warranty. You should review your limited warranty and become familiar with the terms thereof. Other than any such limited warranty, the ChargePoint products are provided "AS IS," and ChargePoint, Inc. and its distributors expressly disclaim all implied warranties, including any warranty of design, merchantability, fitness for a particular purposes and non-infringement, to the maximum extent permitted by law.

Limitation of Liability

CHARGEPOINT IS NOT LIABLE FOR ANY DIRECT, INDIRECT, INCIDENTAL, SPECIAL, PUNITIVE OR CONSEQUENTIAL DAMAGES, INCLUDING WITHOUT LIMITATION LOST PROFITS, LOST BUSINESS, LOST DATA, LOSS OF USE, OR COST OF COVER INCURRED BY YOU ARISING OUT OF OR RELATED TO YOUR PURCHASE OR USE OF, OR INABILITY TO USE, THE CHARGING STATION, UNDER ANY THEORY OF LIABILITY, WHETHER IN AN ACTION IN CONTRACT, STRICT LIABILITY, TORT (INCLUDING NEGLIGENCE) OR OTHER LEGAL OR EQUITABLE THEORY, EVEN IF CHARGEPOINT KNEW OR SHOULD HAVE KNOWN OF THE POSSIBILITY OF SUCH DAMAGES. IN ANY EVENT, THE CUMULATIVE LIABILITY OF CHARGEPOINT FOR ALL CLAIMS WHATSOEVER RELATED TO THE CHARGING STATION WILL NOT EXCEED THE PRICE YOU PAID FOR THE CHARGING STATION. THE LIMITATIONS SET FORTH HEREIN ARE INTENDED TO LIMIT THE LIABILITY OF CHARGEPOINT AND SHALL APPLY NOTWITHSTANDING ANY FAILURE OF ESSENTIAL PURPOSE OF ANY LIMITED REMEDY.

FCC Compliance Statement

Refer to the ChargePoint product nameplate to determine if your product is Class A or Class B.

- **Class A Statement:** This equipment has been tested and found to comply with the limits for a Class A digital device pursuant to Part 15 of the FCC Rules. These limits are designed to provide reasonable protection against harmful interference when the equipment is operated in a commercial environment. This equipment generates, uses, and can radiate radio frequency energy and, if not installed and used in accordance with the manufacturer's instruction manual, may cause harmful interference with radio communications. Operation of this equipment in a residential area is likely to cause harmful interference, in which case, you will be required to correct the interference at your own expense.

Important: Changes or modifications to this product not authorized by ChargePoint, Inc., could affect the EMC compliance and revoke your authority to operate this product.

Exposure to Radio Frequency Energy: The radiated power output of the 802.11 b/g/n radio and cellular modem (optional) in this device is below the FCC radio frequency exposure limits for uncontrolled equipment. The antenna of this product, used under normal conditions, is at least 20 cm away from the body of the user. This device must not be co-located or operated with any other antenna or transmitter by the manufacturer, subject to the conditions of the FCC Grant.

- **Class B Statement:** This equipment has been tested and found to comply with the limits for a Class B digital device, pursuant to part 15 of the FCC Rules. These limits are designed to provide reasonable protection against harmful interference when the equipment is operated in a residential installation. This equipment generates, uses, and can radiate radio frequency energy and, if not installed and used in accordance with the instruction manual, may cause harmful interference to radio communications.

Important: Changes or modifications to this product not authorized by ChargePoint, inc., could affect the EMC compliance and revoke your authority to operate this product.

Exposure to Radio Frequency Energy: The radiated power output of the 802.11 b/g/n radio and cellular modem (optional) in this device is below the FCC radio frequency exposure limits for uncontrolled equipment. The antenna of this product, used under normal conditions, is at least 20 cm away from the body of the user. This device must not be co-located or operated with any other antenna or transmitter by the manufacturer, subject to the conditions of the FCC Grant.

ISED (formerly Industry Canada)

This device complies with the licence-exempt RSS standard(s) of Innovation, Science and Economic Development Canada (ISED). Operation is subject to the following two conditions: (1) this device may not cause interference, and (2) this device must accept any interference, including interference that may cause undesired operation of the device.

Cet appareil est conforme aux flux RSS exemptés de licence d'Innovation, Sciences et Développement économique Canada (ISDE). L'exploitation est autorisée aux deux conditions suivantes : (1) l'appareil ne doit pas produire de brouillage, et (2) l'utilisateur de l'appareil doit accepter.

Radiation Exposure Statement: This equipment complies with the IC RSS-102 radiation exposure limits set forth for an uncontrolled environment. This equipment should be installed and operated with a minimum distance of 20 cm between the radiator and your body.

Énoncé d'exposition aux rayonnements: Cet équipement est conforme aux limites d'exposition aux rayonnements ioniques RSS-102 Pour un environnement incontrôlé. Cet équipement doit être installé et utilisé avec un Distance minimale de 20 cm entre le radiateur et votre corps.

FCC/IC Compliance Labels

Visit [chargepoint.com/labels](https://www.chargepoint.com/labels).