

Express Distro Power Link 2000

One Platform, Infinite Possibilities

Installation Guide for Pedestal Mount



IMPORTANT SAFETY INSTRUCTIONS

SAVE THESE INSTRUCTIONS

This manual contains important instructions for ChargePoint® products that shall be followed during installation, operation and maintenance of each product.

WARNING:



1. **Read and follow all warnings and instructions before servicing, installing, or operating the ChargePoint® product.** Install and operate only as instructed. Failure to do so may lead to death, injury, or property damage, and will void the Limited Warranty.
2. **ChargePoint recommends that installation, commissioning, and break-fix services be performed by a licensed electrician who is also a ChargePoint-certified technician.** These systems operate at high voltage, and without strict adherence to safety protocols, proper protective equipment, and ChargePoint technical guides, there is significant risk to people, equipment, and the environment. Please ensure full compliance with all applicable local and national buildings, electrical, and safety codes.
3. **Always ground the ChargePoint product.** A touch current of >3.5 mA AC RMS is possible in case of a fault condition of loss of electrical continuity of the earthing conductor. Failure to ground the product can lead to risk of electric shock. The product must be connected to a grounded, metal, permanent wiring system, or an equipment grounding conductor shall be run with circuit conductors and connected to the equipment grounding terminal or lead on the Electric Vehicle Supply Equipment (EVSE). Connections to the EVSE shall comply with all applicable codes and ordinances.
4. **Install the ChargePoint product using a ChargePoint-approved method.** Failure to install on a surface that can support the full weight of the product can result in death, personal injury, or property damage. Inspect the product for proper installation before use.
5. **The product is not suitable for use in Class 1 hazardous locations, such as near flammable, explosive, or combustible vapors or gases.**
6. **Supervise children near this device.**
7. **Do not put fingers into the electric vehicle connector or connector adapter. Do not touch fingers to charging rails.**
8. **Do not use this product if any cable is frayed, has broken insulation, or shows any other signs of damage.**
9. **Do not use this product if the enclosure, the flexible output cable, the vehicle inlet, the electric vehicle connector, or the electric vehicle connector adapter is broken, cracked, open, or shows any other signs of damage. Do not use this product if internal parts are accessible, including wiring.**
10. **Wire and wire terminal information are provided in the ChargePoint product Site Design Guide and Installation Guide.**

11. **Torques for installation of wire terminals are provided in the ChargePoint product Installation Guide.**
12. **The ChargePoint product maximum operating temperature is 50 °C (122 °F).**
13. **Do not use an electric vehicle connector adapter with any charger or EV that is capable of exceeding the adapter's rated voltage of current capacity. Some EVs and EVSE combinations are capable of multiple voltages or limited durations of current overloading designed for normal EVSE-to-EV connections. Use of an electric vehicle connector adapter in these situations could result in unsafe conditions such as fire, burns, or exposure of high voltage.**



IMPORTANT: Under no circumstances will compliance with the information in a ChargePoint guide such as this one relieve the user of the responsibility to comply with all applicable codes and safety standards. This document describes approved procedures. If it is not possible to perform the procedures as indicated, contact ChargePoint. ChargePoint is not responsible for any damages that may result from custom installations or procedures not described in this document or that fail to adhere to ChargePoint recommendations.

Warranty Implication



IMPORTANT: Please be advised that all installation, commissioning, and break-fix services must be performed by a ChargePoint-certified technician. Engaging non-certified personnel for these services will result in warranty implications, as doing so constitutes a breach of policy.

Support Services

<https://www.chargepoint.com/legal/support-services>

For more information about ChargePoint's training and certification program, visit <https://www.chargepoint.com/partners/training-certification>

Product Disposal

Applicable to NA - Do not dispose of as part of unsorted domestic waste. Inquire with local authorities regarding proper disposal. Product materials are recyclable as marked.



Applicable to EU - To comply with Directive 2012/19/EU of the European Parliament and of the Council of 4 July 2012 on waste electrical and electronic equipment (WEEE), devices marked with this symbol may not be disposed of as part of unsorted domestic waste inside the European Union. Enquire with local authorities regarding proper disposal. Product materials are recyclable as marked.



Document Accuracy

The specifications and other information in this document were verified to be accurate and complete at the time of its publication. However, due to ongoing product improvement, this information is subject to change at any time without prior notice. For the latest information, see our documentation online at [ChargePoint Product Reference Documentation](#).

Copyright and Trademarks

©2013-2026 ChargePoint, Inc. All rights reserved. This material is protected by the copyright laws of the United States and other countries. It may not be modified, reproduced, or distributed without the prior, express written consent of ChargePoint, Inc. ChargePoint and the ChargePoint logo are trademarks of ChargePoint, Inc., registered in the United States and other countries, and cannot be used without the prior written consent of ChargePoint.

Symbols

This guide and product use the following symbols:



DANGER: Risk of electric shock



WARNING: Risk of personal harm or death



CAUTION: Risk of equipment or property damage



IMPORTANT: Critical detail that must be followed to achieve intended results



NOTE: Important contextual details or procedural clarifications



REINSTALL NOTE: Essential instructions to follow when reinstalling a part or component



Read the manual for instructions



Ground/protective earth

Illustrations Used in This Document

The illustrations used in this document are for demonstration purposes only and may not be an exact representation of the product. However, unless otherwise specified, the underlying instructions are accurate for the product.

Contents

IMPORTANT SAFETY INSTRUCTIONS	i
Revision History	vi
1 Introduction	1
About This Guide	1
Power Link 2000 Overview	2
Product Guides	11
Questions	12
2 Prepare for Installation	13
Check Site Readiness	13
Understand Wire Landing Locations	15
Bring These Tools and Resources	16
Tightening Torque	17
Power Link 2000 Packages	19
Disconnect Power	24
3 Install Power Link 2000	25
Install Leveling Nuts	26
Install Power Link 2000 Assembly	28
Access DC Wire Bus Bars and Terminals	34
Plan for DC Power Path Wire Connect	35
Pull, Cut, and Connect Wires	36
How to Pull DC Power Path Wires	40
How to Connect DC Power Path and Ground Wires	41
How to Connect 48 V DC and Ethernet Wires	48
4 Complete Additional Configurations	57
Install Ethernet to USB Kit	57
Install Card Reader Kit	68
Install Sequential Charging Kit	75
Install Soft Shutdown Switch Wiring	77
Install Safety Hub Jumper Wire in Upstream Power Cabinet	80
5 Install Charging Cables	81
Charging Cable Package	82

Remove Cable Cap	83
Remove High-Power DC Lug Landing Bus Bar Safety Cover	83
Install Cable Assembly	85
Connect High-Power DC and Ground Wires	87
Connect 48 V DC and Ethernet Wires	87
Reinstall High-Power DC Lug Landing Bus Bar Safety Cover	88
Install Holsters	90
6 Install Cable Management Kit	98
Access the Preinstalled CMK Mast	98
Install Standard CMK	101
Install Tall CMK	106
Install Overhead CMK	111
Install Tetherball	114
Suspend Charging Cable	116
Install CMK Covers	119
7 Close and Install Covers	123
Seal Conduit Openings	123
Reinstall Rear Upper Cover	124
Reinstall Side Panels	126
Reinstall Cable Cap	128
Reinstall DC Power Path Bus Bar Safety Cover	130
Record MAC Address	130
Close Enclosure Doors	131
Install Front Upper Cover	132
Install Front Lower Cover	134
Install Top Cap	136
8 Complete Installation Checklist	139
A Appendix: Surface Conduit Entry Kit Installation	140
Required Tools and Materials	140
Kit Components	141
Install Anchor Bolts	143
Install Gland Plate	146
Install Surface Conduits (LCC)	148
Install Surface Conduits (Non-LCC)	155
B Appendix: Set Up Power Link 2000	160
Power On	160
Set Up Power Link 2000	161

Revision History

This page provides a summary of revisions made, listing the month and year of each update along with a brief description of the changes made.

Month & Year	Description
June 2026	Early access draft - initial release.

Introduction 1

This section describes the purpose and scope of this guide and provides an overview of the ChargePoint® Express Distro Power Link 2000 .

About This Guide

This guide provides instructions for installing the pedestal-mount Power Link 2000. It covers preparation requirements, mounting and anchoring procedures, electrical and communication connections, commissioning steps, and verification tasks needed to place the station into service.

This guide is intended for licensed electricians, installation contractors, and construction professionals responsible for installing Power Link 2000 equipment in accordance with local codes and ChargePoint requirements.

Please note that Power Link 2000 is available in multiple variations and mount types, and installation procedures differ for each. This installation guide applies specifically to *Variation B pedestal-mount* Power Link 2000s.

To ensure this guide is applicable to your unit, verify the part number of your charging station. The part number can be found on the Power Link 2000 package shipping label and is formatted as 99-XXXXXX-YY-ZZ, where:

- 99-XXXXXX is the base part number
- YY is a version enumerator
- ZZ is a variant indicator

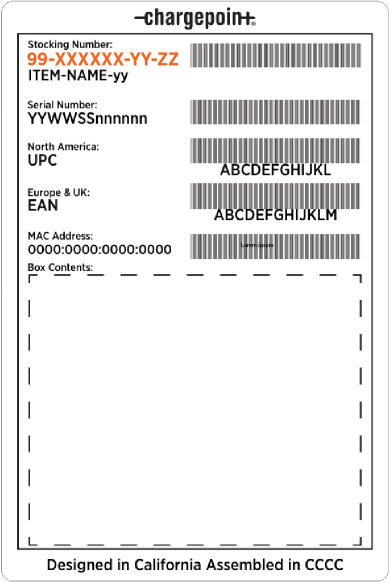

This guide is not applicable for certain pedestal-mount Power Link 2000 part numbers. If the Power Link 2000 part number has a base part number and version enumerator that exactly matches one listed below, you must obtain a different installation guide. This is not the correct guide.

- 99-007902-03
- 99-007904-03
- 99-007910-02
- 99-007911-02
- 99-007916-02

Power Link 2000 Overview

Power Link 2000 is a product within the Express DC fast charging platform. Power Link 2000 is a charging dispenser that delivers DC power to EVs through flexible, lightweight charging cables equipped with industry standard connectors such as CCS1, CCS2, CHAdeMO, MCS, and NACS. The Power Link 2000 can accommodate up to two charging cables to charge two electric vehicles simultaneously or sequentially.

Power Link 2000 requires input power from a power cabinet. For information on power cabinets and other modular EVSEs in the Express product family, refer to the Express platform documents at [ChargePoint Product Reference Documentation](#).

Cabinet Configurations

The Power Link 2000 is a vertical cabinet that is available in the following variants:

- **Pedestal-Mount Power Link 2000** – Designed for installation on a concrete ground surface. This variant includes charging cable holsters and an interactive display, and is available with either single or dual charging cables.
- **Overhead-Mount Power Link 2000** – Designed for installation on a wall or overhead structure (such as a gantry or ceiling-mounted support). This variant is also available with either single or dual charging cables.

Pedestal-Mount

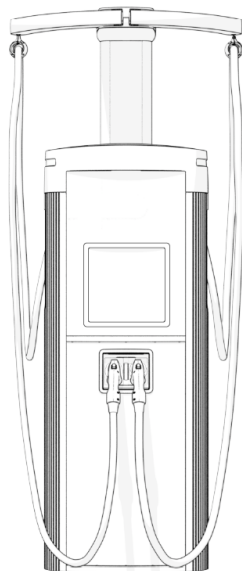

Overhead-Mount

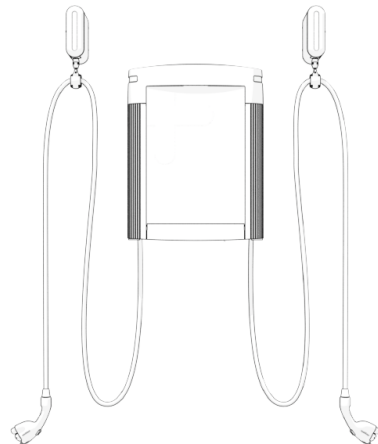



IMPORTANT: This guide is for pedestal-mount Power Link 2000s. If your unit is an overhead-mount Power Link 2000, refer to the *Express Distro Overhead-Mount Power Link 2000 Installation Guide*, available at [ChargePoint Product Reference Documentation](#).

Charging Cable Type and Quantity

Depending on the charging speed and connectors required, pedestal-mount Power Link 2000s can be installed with one or two liquid-cooled cables (LCC) or non-liquid-cooled cables (non-LCC). The pedestal-mount Power Link 2000 with LCC comes with a liquid cooling system attached to the back of the enclosure.

Pedestal-Mount with Single or Dual LCC

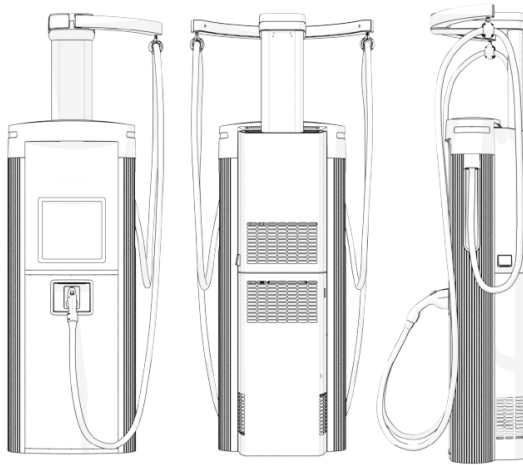

Pedestal-Mount with Single or Dual Non-LCC

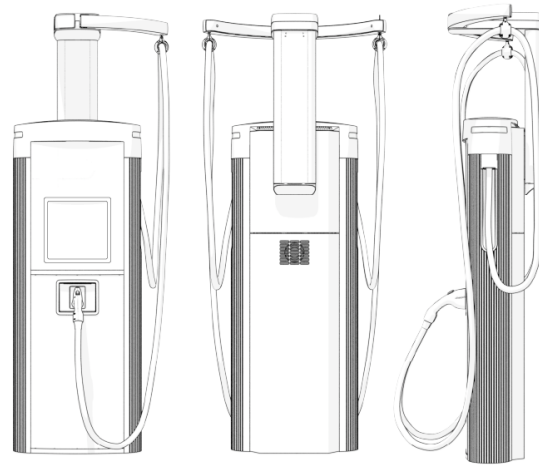

Charging Cable Length and Cable Management Kits

Depending on the required cable reach, the pedestal-mount Power Link 2000 can be installed with a standard cable management kit (CMK) to manage standard length (up to 5.8 m or 19 ft) charging cables, or with a tall CMK or overhead CMK to manage medium length (7.6 m or 25 ft) charging cables. The image below shows the CMK options installed with a pedestal-mount Power Link 2000.

Standard CMK

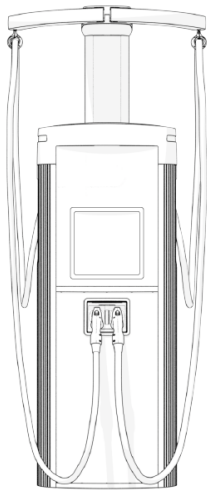

Tall CMK

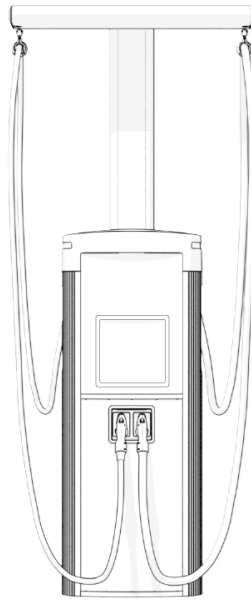

Overhead CMK

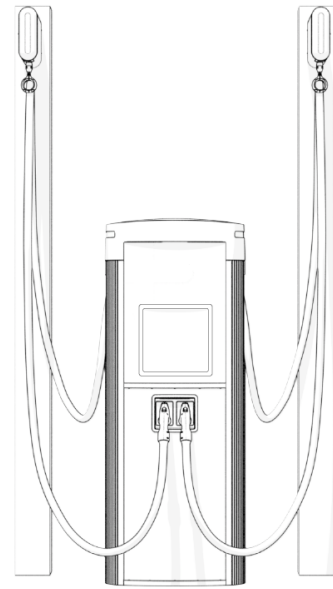

The CMKs function as follows:

- **Standard CMK** – Moveable arms on the CMK swing suspended charging cables out and forward for charging and retract cables to rest position between charges. The standard CMK is available with single or dual swing arms.

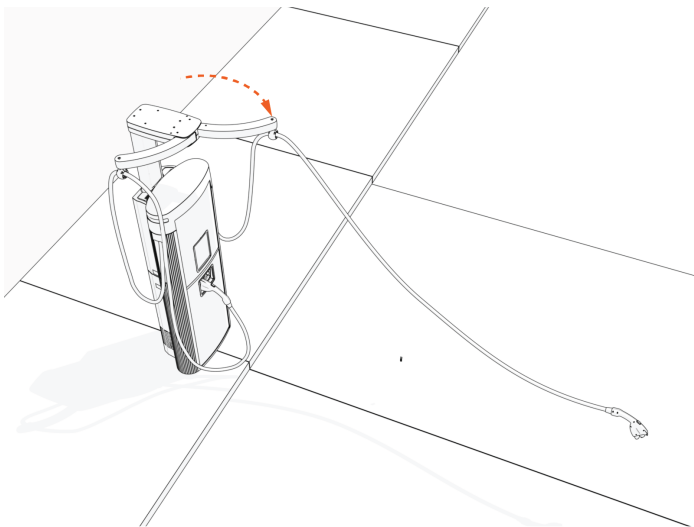

- **Tail CMK** – A tether cord extends out of the CMK as the suspended charging cable is pulled out and forward for charging. The tether cord retracts when the cable is returned, keeping the cable off the ground throughout use.

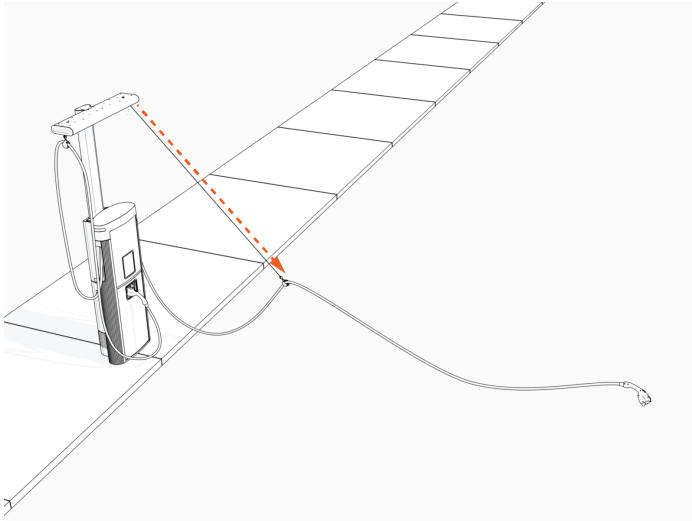

- **Overhead CMK** – The CMK suspends charging cables and uses a retractable tether cord to support the cable as it is pulled toward the vehicle and to lift it back to its rest position when released.

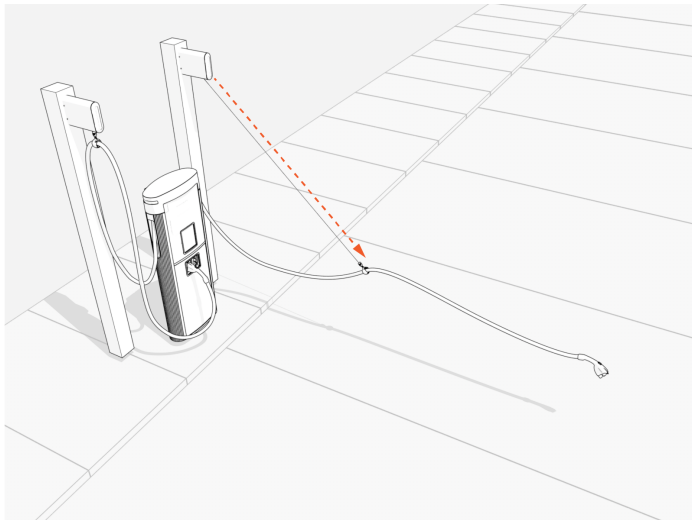

Exterior Parts

The following shows an exterior view of a Power Link 2000 equipped with a standard CMK.

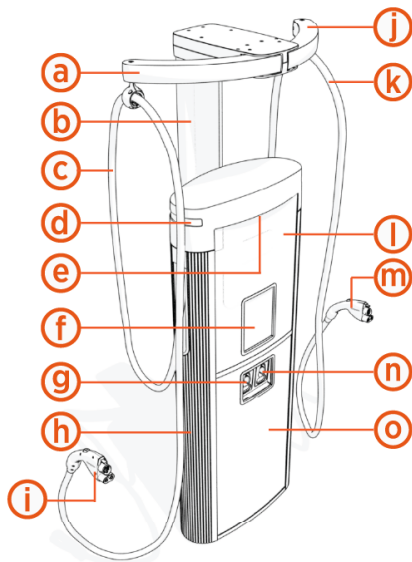

Front View

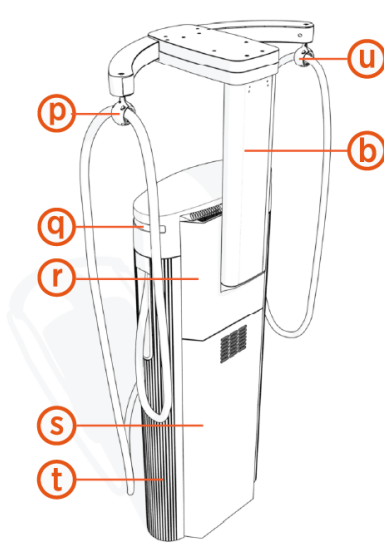

Rear View (non-LCC)

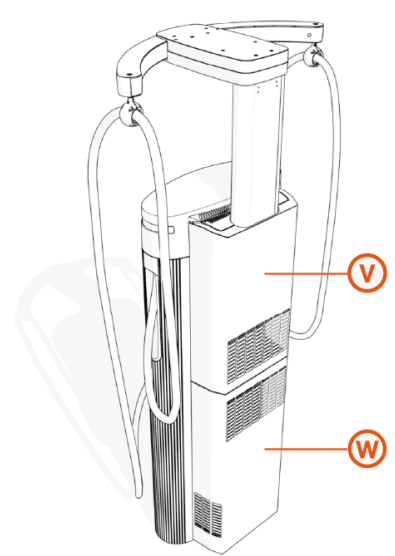

Rear View (LCC)

Ref	Part	Ref	Part
(a)	Standard CMK swingarm, left	(m)	Charging connector, right
(b)	Standard CMK mast	(n)	Holster, right
(c)	Charging cable, left	(o)	Lower cover and door (with customizable vinyl)
(d)	Status LED, left	(p)	Tetherball, right
(e)	Area downlight (front – illumination side)	(q)	Status LED, right
(f)	Display/CCOM assembly (display side)(*)	(r)	Upper rear cover (non-LCC)
(g)	Holster, left	(s)	Lower rear cover (non-LCC)
(h)	Side panel (side extrusion), left	(t)	Side panel (side extrusion), right
(i)	Charging connector, left	(u)	Tetherball, left
(j)	Standard CMK swingarm, right	(v)	Upper rear cover (LCC)
(k)	Charging cable, right	(w)	Lower rear cover (LCC)
(l)	Upper cover and door (with customizable vinyl)		



NOTE: (*) CCOM = Communications and Control Module

Interior Parts

The following shows an interior view of the Power Link 2000, with covers and panels removed.

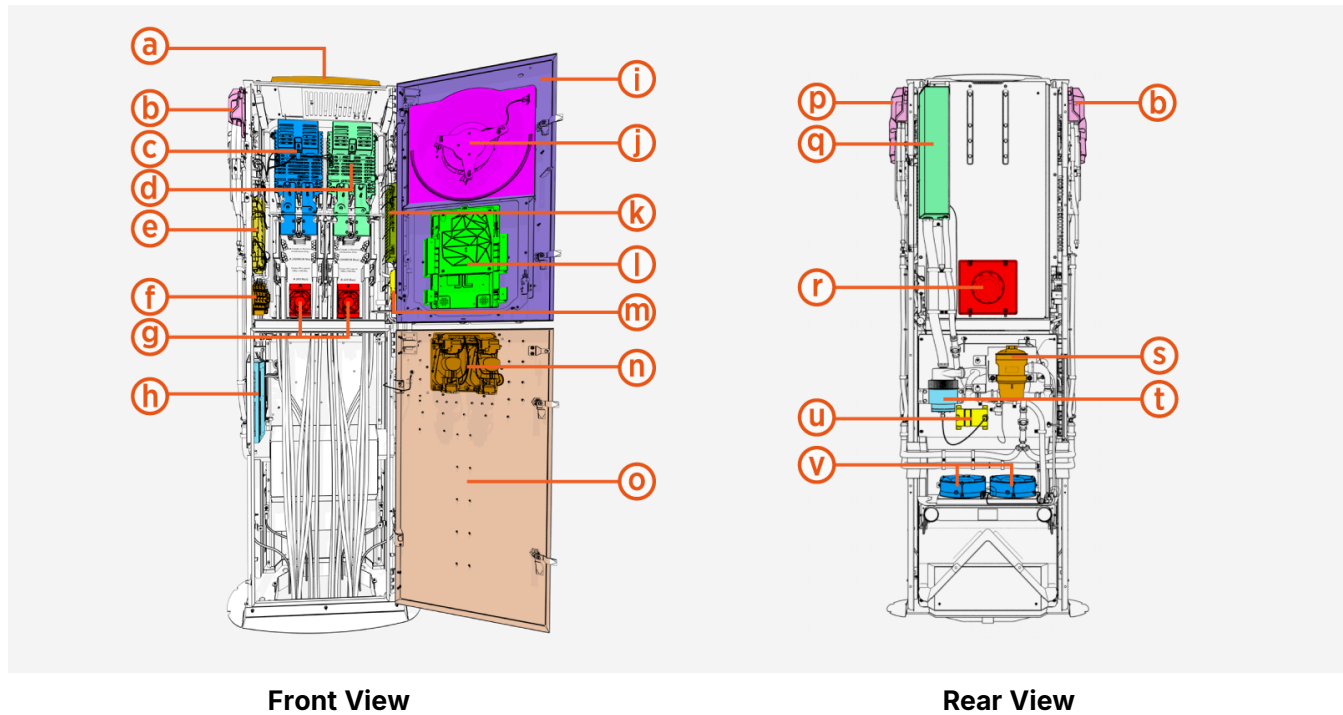

Ref	Part	Ref	Part
(a)	Smart antenna (option)	(l)	Display/CCOM Assembly (CCOM side)
(b)	Charging cable assembly, left	(m)	Smart Ethernet Switch
(c)	DC Input Power Path Assembly A(*)	(n)	Holsters, interior view
(d)	DC Input Power Path Assembly B(*)	(o)	Lower enclosure door
(e)	Power Link 2000 controller	(p)	Charging cable assembly, right
(f)	Terminal block (48 V DC and soft shutdown switch)	(q)	Coolant reservoir (LCC units only)
(g)	Internal fans	(r)	External fan
(h)	Cooling controller (LCC units only)	(s)	Ion filter (LCC units only)
(i)	Upper enclosure door	(t)	Pump (LCC units only)
(j)	Door fan	(u)	Pump controller (LCC units only)
(k)	Ethernet switch (SSLAN)	(v)	LCC fans (LCC units only)



NOTE: (*) Each power path assembly consists of a Proton module coupled with input/output bus bars.

Wire Entry

- **Stub-up entry:** Wires can enter pedestal-mount Power Link 2000s through the bottom of the enclosures via conduits or armored cables laid underground.
- **Surface entry:** At sites where the wires cannot be laid underground, they can enter into pedestal-mount Power Link 2000s through the rear side of the enclosures via conduits or armored cables laid above ground. For more information, refer to [Appendix: Surface Conduit Entry Kit Installation](#).

System Description

The Power Link 2000 is a single-port or dual-port DC charging dispenser designed to interface with upstream ChargePoint Express power cabinets such as Express Solo or Power Block 2000.

The Power Link 2000 is equipped with up to two independent DC power paths:

- **Power Path A** – serves the left charging point
- **Power Path B** – serves the right charging point

Each power path may be configured to receive DC power from an upstream power cabinet and uses internal switching components to safely connect or disconnect power to each charging cable.

The Power Link 2000 also receives 48 V DC auxiliary power from the upstream cabinet's Auxiliary Power Supply (AUX PS). This power supports control electronics, communication hardware, UX systems, and sensor and safety circuits.

In addition, the Power Link 2000 maintains Ethernet communication with the upstream power cabinet for coordination, monitoring, and control.

The Power Link 2000 features an integrated control and safety system:

- **Power Link 2000 Controller** – An isolated power-control board with some auxiliary interface functions.
- **Protons** – Each power path utilizes a Proton module that contains switching elements for connecting or isolating the EV from the incoming DC supply. The Proton also provides integrated DC metering for monitoring voltage and current delivered to the EV. It enables the Power Link 2000 to safely energize the EV only after the charging handshake is complete, and it opens safely during faults, door-open events, or shutdown conditions. The Proton also allows for the same DC power to be connected to multiple power paths in sequential charging applications.
- **Control and Communication Module (CCOM)** – This module manages local user-experience hardware, communication interfaces, and connectivity functions within the dispenser. The CCOM supports the display, authentication hardware, status indicators, and other UX components, and it provides the communication link between the Power Link 2000 Controller and external systems.

The Power Link 2000 provides an integrated user interface for EV drivers, including a high visibility display, authentication hardware (e.g., RFID reader, credit card reader), LED status indicators, and a cable management system.

System Interfaces and Sample Architectures

This section provides a high-level overview of the electrical interfaces of a Power Link 2000. The interfaces are illustrated within the context of a few example architectures in which the Power Link 2000 is deployed with upstream power cabinets or in power pass-through configuration.

Below is an example architecture in which an Express Solo power cabinet serves a single Power Link 2000. For further details on Express Solo interfaces, refer to the *Express Solo Site Design Guide*.

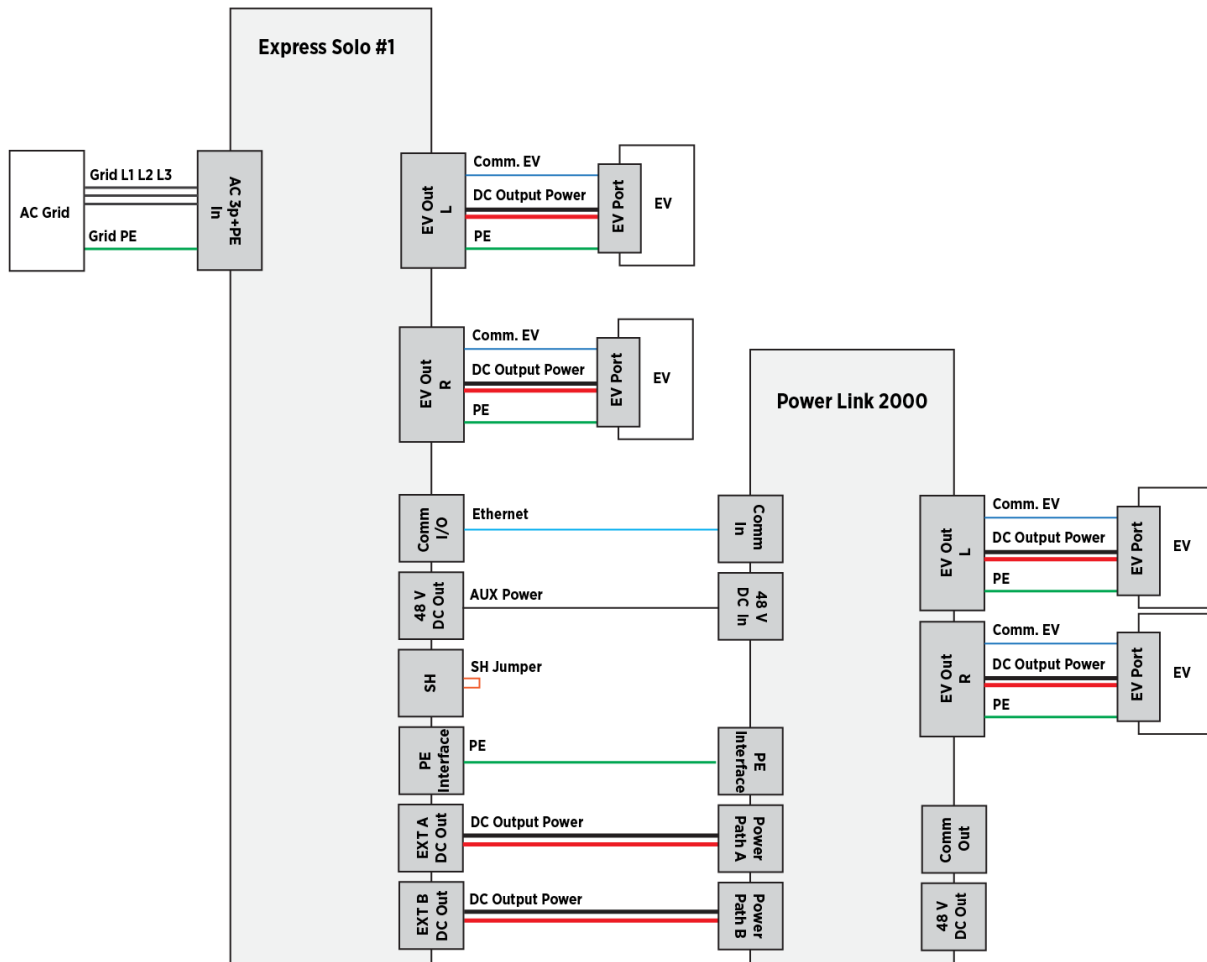

The next diagram shows a configuration in which a Power Block 2000 power cabinet supplies two Power Link 2000 dispensers. For further details on Power Block 2000 interfaces, refer to the *Express Distro Power Block 2000 Site Design Guide*.

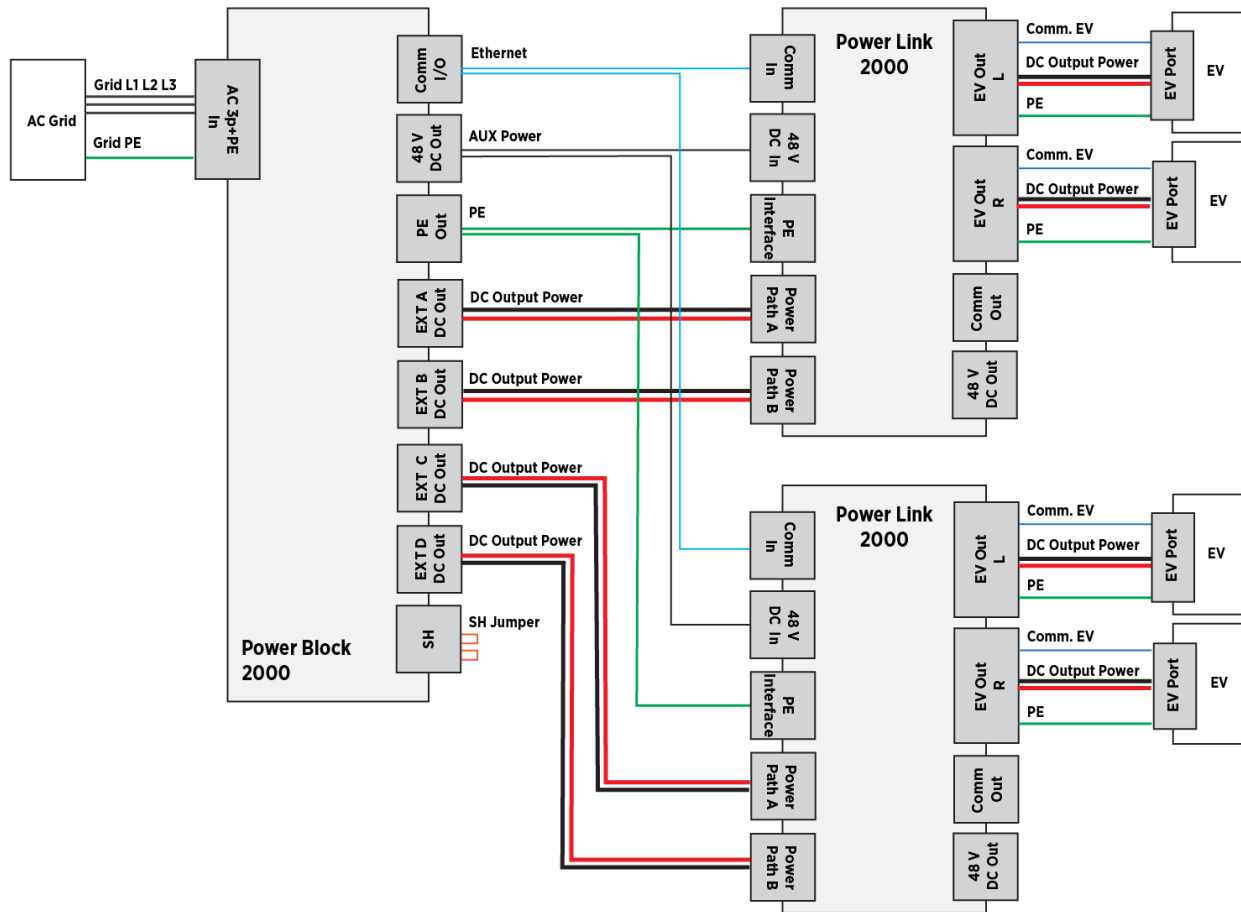

In certain system configurations, Ethernet and 48 V DC auxiliary power from an upstream power cabinet shall be connected from one Power Link 2000 to another, an arrangement known as daisy-chaining.

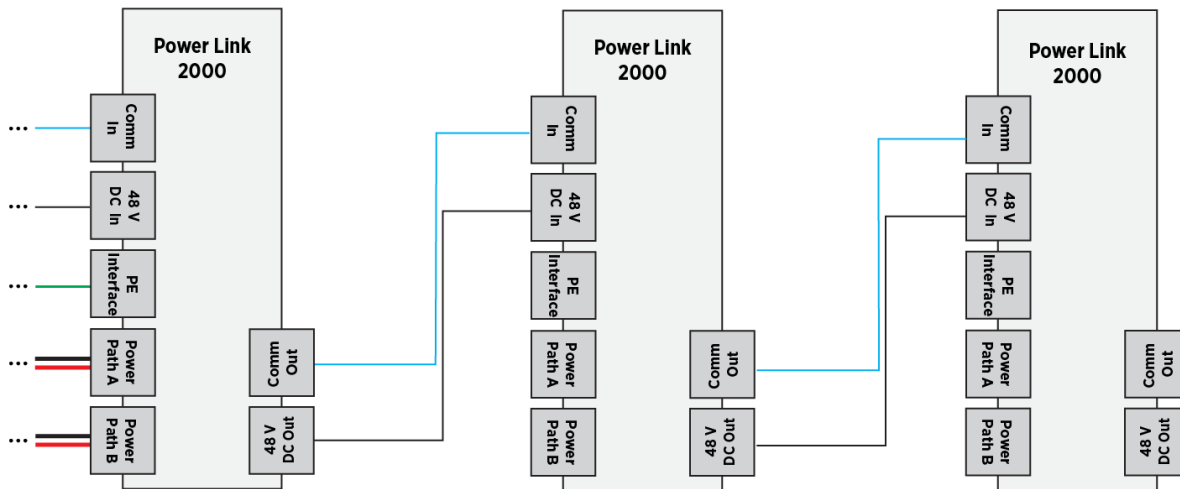

IMPORTANT: Power Link 2000 can be configured in many different system architectures, only a few of which are shown above. The actual architecture for each site will vary depending on the number of stations, the charging capacity required at each charging station, charging requirements, and other criteria. If you are a site designer, contact a ChargePoint representative for the ChargePoint-approved wiring architecture for your specific project. Systems configured with non-approved wiring between Power Link 2000 and connected EVSEs may not function as expected. If you are an installer, see the site plan for the architecture specific to the site installation project.

Product Guides

A full suite of guides is available for Power Link 2000, as summarized below.

Document	Content	Primary Audiences
Datasheet	Full station specifications	Site designer, installer, and station owner
Site Design Guide	Civil, mechanical, and electrical guidelines to scope and construct the site	Site designer, responsible engineer, contractors, installers
Construction Signoff Form	Checklists used by contractors to ensure the site is correctly completed and ready for product installation	Site construction contractor
Installation Guide	Anchoring, wiring, and powering	Installer

Document	Content	Primary Audiences
	on	
Operation and Maintenance Guide	Operation and preventive maintenance information	Station owner, facility manager, and technician
Service Guide	Component replacement procedures, including optional components	Service technician
Declaration of Conformity	Statement of conformity with directives	Purchasers and public

Access ChargePoint documents at [ChargePoint Product Reference Documentation](#).

Questions

For assistance, go to chargepoint.com/support and contact technical support using the appropriate region-specific number.

Prepare for Installation 2

This section describes how to prepare for the installation.

Check Site Readiness

To check site readiness, complete this checklist before you install Power Link 2000.

Power Link 2000 Site Readiness Checklist		
1.	The electrical equipment is installed and labeled in accordance with the applicable national electrical code — such as NFPA70, the Canadian Electrical Code (CSA No 22.1), IEC 60364, or BS7671, depending on the installation region — and all applicable requirements of the serving electric utility company and the authority having jurisdiction.	<input type="checkbox"/>
2.	The upstream power cabinets are installed at locations proposed in the site drawings.	<input type="checkbox"/>
3.	The concrete pad or concrete surface meets the mounting specifications given in the <i>Express Distro Power Link 2000 Site Design Guide</i> and/or is inspected and approved by a structural engineer for the dimensions and weights (as given in the <i>Express Distro Power Link 2000 Site Design Guide</i>) of the Power Link 2000 and its related components such as charging cable(s) and Cable Management Kit (CMK).	<input type="checkbox"/>
4.	Wires and conduits meet the requirements given in the site drawings.	<input type="checkbox"/>
5.	The installation site meets the drainage, ventilation guidelines, and clearances given in the <i>Express Distro Power Link 2000 Site Design Guide</i> .	<input type="checkbox"/>
6.	The slope at the installation site does not exceed 20 mm per meter (0.25 in per ft). If necessary, use a grinder or a hammer and chisel to remove any concrete that is not level with the rest of the concrete pad or surface.	<input type="checkbox"/>
7.	Sufficient space is available to use a forklift or other lifting equipment, unpack, remove packing materials, and allow two people to freely move throughout the site.	<input type="checkbox"/>
8.	The anchor bolts, conduits, and concrete pad meet the requirements listed below: <ul style="list-style-type: none"> • The anchor bolts are installed, are 76 mm (3 in) high from the concrete pad, and are plumb. • The conduits or armored cables are laid per the conduit layout given in the <i>Express Distro Power Link 2000 Site Design Guide</i>. • In regions that use conduits, the conduits do not have bell ends, are plumb, and are 102–160 mm (4–6.3 in) high from the concrete pad. Conduits with bell ends may interfere with tolerances inside the Power Link 2000. • The concrete pad is fully cured and smooth. 	<input type="checkbox"/>

Power Link 2000 Site Readiness Checklist

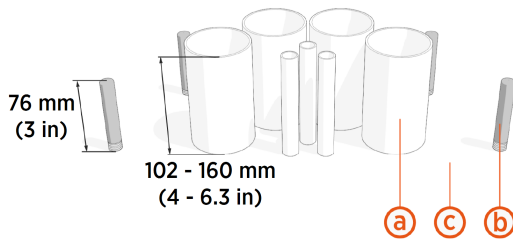

- (a) Conduits
- (b) Anchor bolts with protective caps
- (c) Concrete pad

9. In regions that use conduits, wires can be pulled before or after mounting the Power Link 2000. If you want to pull wires before mounting or if the site is using armored cables directly buried and exposed from underground, make sure that the wires reach the bus bars at the following height.

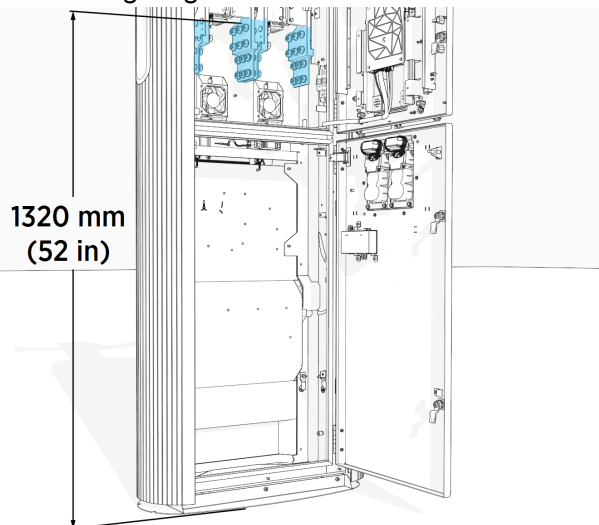

Check Electrical Readiness

For electrical input and output specifications, refer to the *Express Distro Power Link 2000 Datasheet* and *Express Distro Power Link 2000 Site Design Guide* at [ChargePoint Product Reference Documentation](#) .

Understand Wire Landing Locations



NOTE: Depending on configuration, the pedestal-mount Power Link 2000 has one or two DC power paths, named A and B. Each power path has two wire landings, an upper landing and a lower landing. Power Link 2000s with a single charging cable are configured with Power Path B landings only.

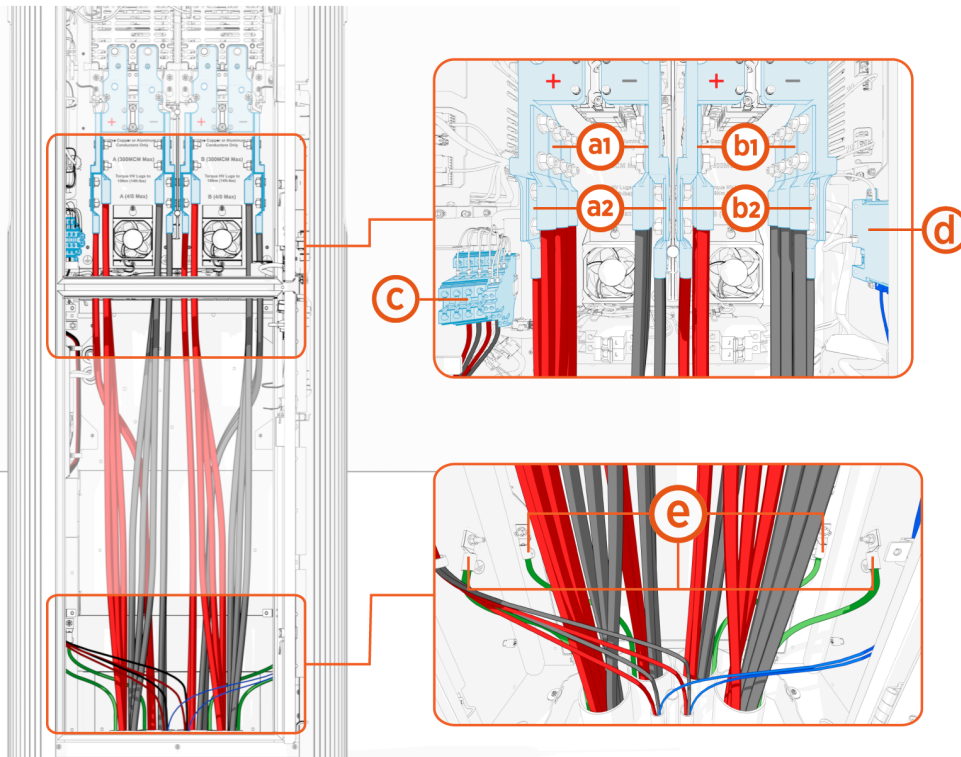

- (a1) DC Power Path A, upper landing
- (a2) DC Power Path A, lower landing
- (b1) DC Power Path B, upper landing
- (b2) DC Power Path B, lower landing
- (c) 48 V DC and soft shutdown
- (d) Ethernet
- (e) Ground



NOTE: In this guide, "ground" refers to Protective Earth (PE).

Bring These Tools and Resources

Installing the Power Link 2000 requires at least two people. Additionally, the installer must bring the following tools and materials. These are not provided by ChargePoint.

CAUTION: Comply with these guidelines to prevent component damage.



- Use tools suitable to torque metric fasteners. All fasteners used on the Power Link 2000 are in metric sizes.
- Use the given torque values to tighten the fasteners.
- Ensure that the tools such as torque tool, multimeter, and Ethernet tester are calibrated.

Required Tools and Materials



Forklift with anti-slip forks

- Rated for ≥ 680 kg (1500 lb)
- Fork specifications:
 - Width = 102–127 mm (4–5 in)
 - Thickness ≤ 57 mm (2.25 in)
- If your site has height constraints, use alternative equipment



Stepladder



Industrial vacuum cleaner



Paper towel roll



Wire brush (to remove any residue on anchor bolts)



Duct seal compound



Hard hat



Cut-resistant gloves



Safety glasses



Cable ties



Cable puller or fish tape



Measuring tape or other tool to measure linear dimensions



Level



Lockout/Tagout equipment



Multimeter (meter and probes rated for 1000 V)









Ethernet tester such as a Klein Tools VDV526-052 VDV LAN Scout Jr. Tester or similar



Conduit cutter (refer to site plans for conduit sizes)



Box cutter

	Wire cutters		Wire strippers
	Lug crimping tool and die		Ethernet (RJ45) connector crimping tool
	Torque wrench		Torque screwdriver
	Shallow socket set (7 mm, 10 mm, 17 mm) and 24 mm deep socket		Hex wrench set
	Torx screwdriver (T20, T30)		T25 Security screwdriver
	Flathead screwdriver set, including 2.5 mm and 3.5 mm tip for terminal blocks		Phillips head screwdriver set
	Torque paint pen		Permanent marker
	Anti-oxidant joint compound (to make gastight joint between wire and lug) and wire pulling lubricant		Dielectric grease
	Smartphone with: <ul style="list-style-type: none"> • Internet connectivity 		<ul style="list-style-type: none"> • ChargePoint installer login credentials
	<ul style="list-style-type: none"> • QR code scanner (usually built into the camera app) 		<ul style="list-style-type: none"> • ChargePointInstaller app

Wires and Terminations

Gather all wires and wire terminations required for the installation project. Refer to the *Express Distro Power Link 2000 Site Design Guide* for general system wire specifications and refer to the site plan for wires and terminations required specifically for the installation project.

Tightening Torque

Component (xFastener Quantity)	Component Material	Fastener	Tool	Torque
Charging cable bus bar safety cover (x1 or x2)	Plastic	M4	T20 Torx	1.7 Nm (15 in-lb)
Top cap, front (x2)	Plastic	M4	T25 Security	
CMK tetherball (x5)	Metal	M4	T20 Torx	2.8 Nm (25 in-lb)

Component (xFastener Quantity)	Component Material	Fastener	Tool	Torque
<u>Standard holster</u> (x4 or x8)	Plastic	M5	T25 Security	
<u>Top cap, rear</u> (x2)	Plastic	M5	T25 Security	
<u>Charging cable assembly</u> (x4 or x8)	Metal	M5	T25 Security	4.5 Nm (40 in-lb)
<u>SCE mounting bracket</u> (x4)	Metal	M5	8 mm socket	
<u>Ethernet to USB</u> (x2)	Metal	M5	8 mm socket	
<u>Conduit opening sleeve or gland plate</u> (x2)	Metal	M5	T25 Security	
<u>Omni Port</u> (x2)	Metal	M5	T25 Security	
<u>Rear upper and lower cover, LCC</u> (x6)	Metal	M5	T25 Security	
<u>Side panels</u> (x2 or x4)	Metal	M5	T25 Security	
<u>Ground wire lug nut</u> (up to x4)	Metal	M6	10 mm socket	
<u>Charging cable DC wire lug nuts</u> (x8 or x16)	Metal	M6	10 mm socket	
<u>Charging cable ground wire lug nut</u> (x1 or x2)	Metal	M6	10 mm socket	
<u>CMK swingarm assembly</u> (x5)	Metal	M6	T25 Security	
<u>CMK mast</u> (x8)	Metal	M6	T30 Torx	
<u>Overhead CMK screws</u> (x4)	Metal	M6	T25 Security	3.4 Nm (30 in-lb)
<u>Overhead CMK nuts</u> (x4)	Metal	M8	13 mm socket	12.2 Nm (108 in-lb)
<u>Sequential charging bus bar</u> (x4)	Metal	M8	13 mm socket	
<u>Tall CMK assembly</u> (x4)	Metal	M10	6 mm hex	13.5 Nm (120 in-lb)
<u>DC power path wire lug nuts</u> (up to x48)	Metal	M10	17 mm socket	19 Nm (14 ft-lb)
<u>Anchor bolt base nuts</u> (x4)	Metal	M16	24 mm deep socket	54.2 Nm (40 ft-lb)
<u>Power Link 2000 mounting nuts</u> (x4)	Metal	M16	24 mm deep socket	94.9 Nm (70 ft-lb)
<u>48 V DC wire terminal block set screws</u> (up to x8)			3.5 mm flathead screwdriver	1.5 Nm (13.3 in-lb)
<u>Soft shutdown terminal screws</u> (x2)			2.5 mm flathead screwdriver	0.6 Nm (5.3 in-lb)

Power Link 2000 Packages



WARNING: The crate is heavy and can cause injury or death if dropped. Do not stand or walk beneath the crate while it is being lifted. Take precautions against the crate tipping or sliding.



CAUTION: Always transport and store components in their original packaging. Use appropriate lifting equipment (forklift or crane, lifting straps, and any corresponding attachments and accessories). Ensure the load rating of all lifting equipment is adequate for the weight of the crated components.



CAUTION: Keep components in original packaging, free of moisture, and protected from damage until you install or service them at the site. Store all shipments of components in a dry covered location and protect from moisture.



CAUTION: To protect the charging cables from damage, keep them wrapped throughout the installation process.



IMPORTANT: Leave components in the shipping crate until needed. When removing, protect them from damage (such as scratches) by placing them flat on a blanket or tarp, face up. Do not stand up cover panels, as they may be knocked or blown over. Cover charging connectors to prevent damage or ingress.



IMPORTANT: Keep components out of direct sunlight in a cool area until you install them.

Package Configurations, Dimensions, and Weights

Power Link 2000 with non-LCC

Power Link 2000 with non-LCC ship with the charging station enclosure, charging cable, and cable management kit (CMK) each placed in separate packages. Also, the cosmetic top cap and covers ship together in a separate package.

Package	Variant	Dimensions (L x W x H)	Max. Weight
<u>Power Link 2000 non-LCC configuration</u> (enclosure only)	-	2.34 x 0.96 x 0.61 m (92.25 x 38.13 x 24.13 in)	173 kg (380 lbs)
<u>Charging cable</u> (non-LCC)	Standard length (5.8 m or 19 ft)	0.72 x 0.58 x 0.22 m (28.45 x 22.74 x 8.75 in)	23 kg (50 lbs)
	Medium length (7.6 m or 25 ft)		32 kg (70 lbs)
<u>CMK</u>	Standard	1.12 x 0.65 x 0.24 m (44.13 x 25.75 x 9.5 in)	28 kg (60 lbs)
	Tall	1.87 x 0.35 x 0.40 m (73.50 x 14.75 x 16.13 in)	41 kg (90 lbs)
	Overhead CMK	0.45 x 0.40 x 0.18 m (17.50 x 15.88 x 7 in)	12 kg (25 lbs)
<u>Cosmetic kit</u> (top cap and covers)	-	1.11 x 0.53 x 0.64 m (44 x 21 x 25 in)	15 kg (33 lbs)

Power Link 2000 with LCC

Power Link 2000 with LCC ship with the charging station enclosure, charging cables, and standard CMK placed in a single package. The charging cables and CMK mast are preinstalled on the charging station enclosure. The cosmetic top cap and covers ship together in a separate package.

Package	Variant	Dimensions (L x W x H)	Max. Weight
<u>Power Link 2000 LCC configuration</u> (enclosure with dual LCCs and standard CMK(*))	-	2.49 x 1.12 x 0.82 m (98 x 44 x 32.38 in)	318 kg (700 lbs)
<u>Cosmetic kit</u> (top cap and covers)	-	1.11 x 0.53 x 0.64 m (44 x 21 x 25 in)	15 kg (33 lbs)



NOTE: (*) The LCC(s) and CMK mast ship preinstalled on the charging station enclosure

Additional Kits

Package	Variant	Dimensions (L x W x H)	Max. Weight
Ethernet to USB Kit	-	0.3 x 0.39 x 0.22 m (11.81 x 15.35 x 8.66 in)	1.36 kg (3 lb)
Card Reader Kit	-	0.89 x 0.63 x 0.29 m (35.13 x 24.75 x 11.38 in)	0.5 kg (1 lb)
Sequential Charging Kit	-	0.27 x 0.18 x 0.05 m (10.6 x 7.0 x 1.8 in)	2.3 kg (5 lb)

Power Link 2000 Non-LCC Configuration Package

Check the package for the following components:



NOTE: For any missing component, contact chargepoint.com/support.

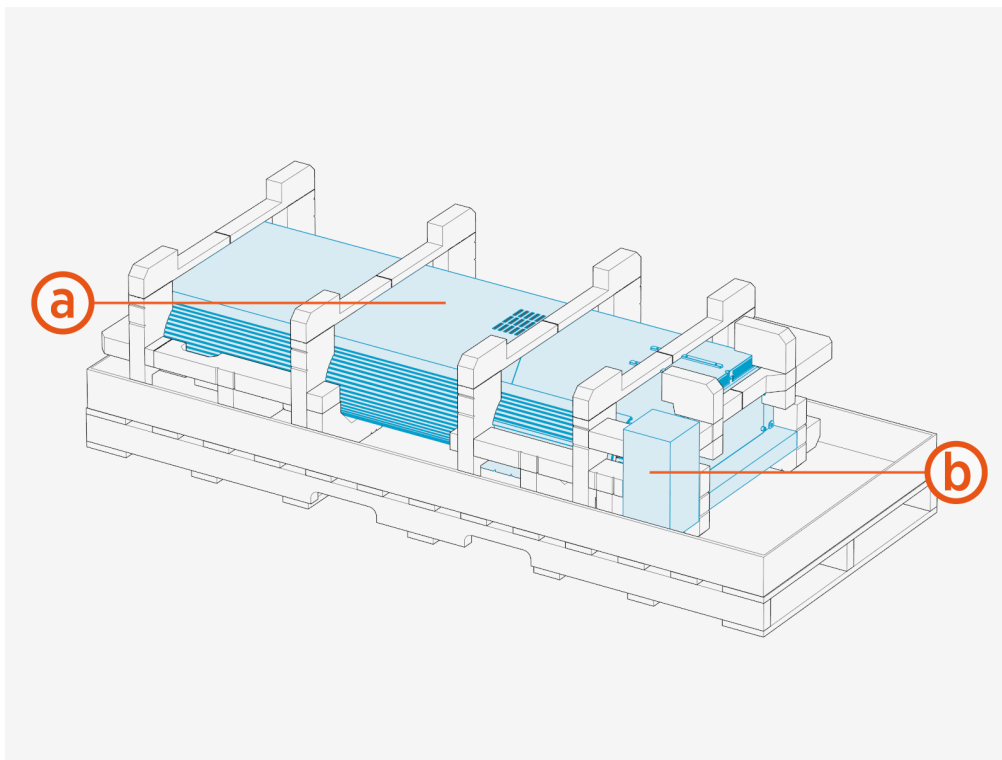

- (a)** Power Link 2000 assembly
- (b)** Install kit, which contains the following components:
 - i. M16 hex nuts and washers for mounting Power Link 2000 (x12)
 - ii. T25 Security screwdriver
 - iii. Sealant for sealing the conduit opening (x5)
 - iv. Safety Hub jumper wire (*)



NOTE: (*) The Safety Hub jumper wire may ship inside the Power Link 2000 package or in a separate package that ships with the Power Link 2000 unit.

Power Link 2000 LCC Configuration Package

Check the package for the following components:



NOTE: For any missing component, contact chargepoint.com/support.

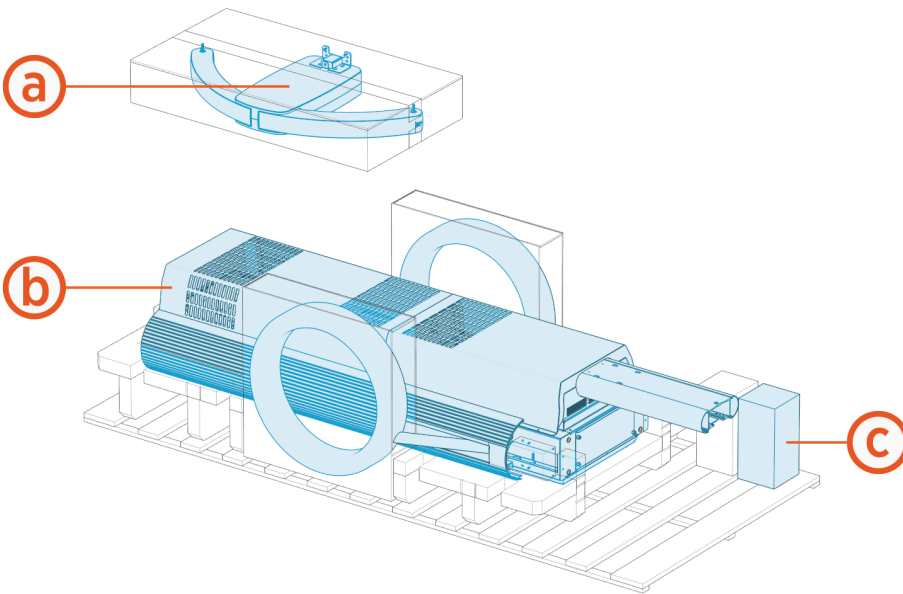

- (a) CMK swingarm assembly with one or two swingarms
- (b) Power Link 2000 assembly with pre-installed charging cables and CMK mast
- (c) Install kit, which contains the following components:
 - i. M16 hex nuts and washers for mounting Power Link 2000 (x12)
 - ii. T25 Security screwdriver
 - iii. Sealant for sealing the conduit opening (x5)
 - iv. Safety Hub jumper wire (*)



NOTE: (*) The Safety Hub jumper wire may ship inside the Power Link 2000 package or in a separate package that ships with the Power Link 2000 unit.

Cosmetic Kit Package

Check the cosmetic kit package for the following components:



NOTE: For any missing component, contact chargepoint.com/support.

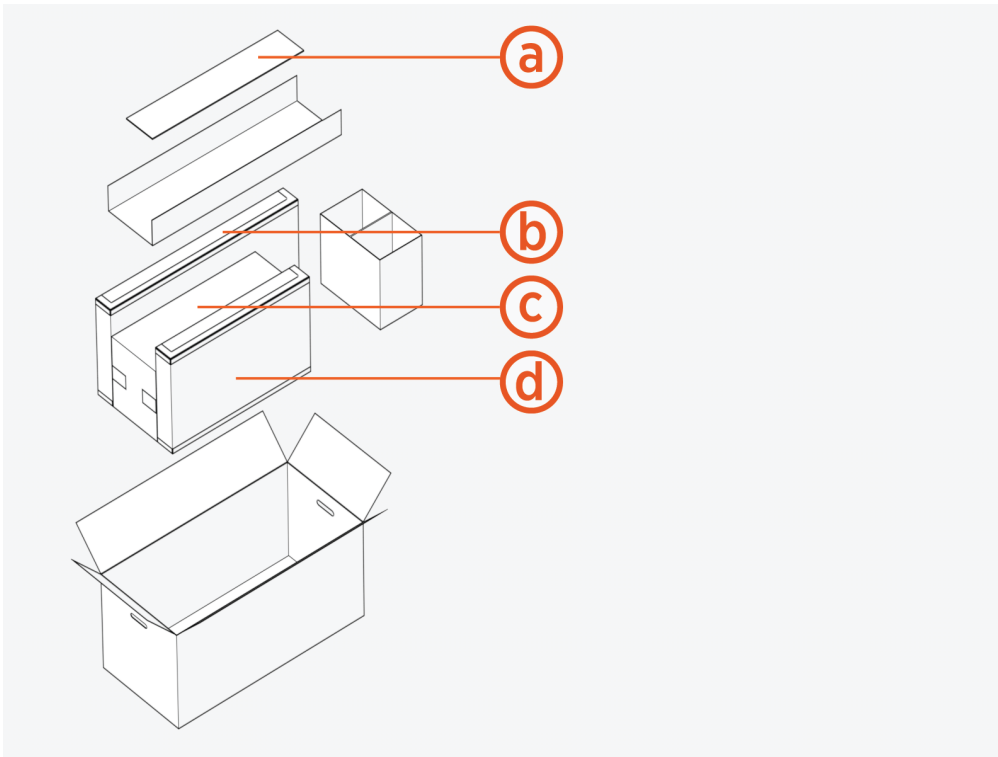

- (a)** CMK mast covers (front and rear)
- (b)** Power Link 2000 front lower cover
- (c)** Power Link 2000 top cap
- (d)** Power Link 2000 front upper cover

Disconnect Power

To disconnect power, complete the following steps:

DANGER: RISK OF SHOCK



- Before any procedure, disconnect the power.
- Follow local code and site lockout/tagout procedure to de-energize the station.
- Wait for energy to dissipate (approximately five minutes).
- Keep power off until all covers and panels are reinstalled and the work is complete.

FAILURE TO FOLLOW THESE INSTRUCTIONS CAN RESULT IN SERIOUS INJURY, LOSS OF LIFE, OR PROPERTY DAMAGE.

1. Disconnect power at the site electrical panel.



NOTE: Follow standard practice and local code to de-energize the applicable circuit and lock out/tag out the disconnect before proceeding.

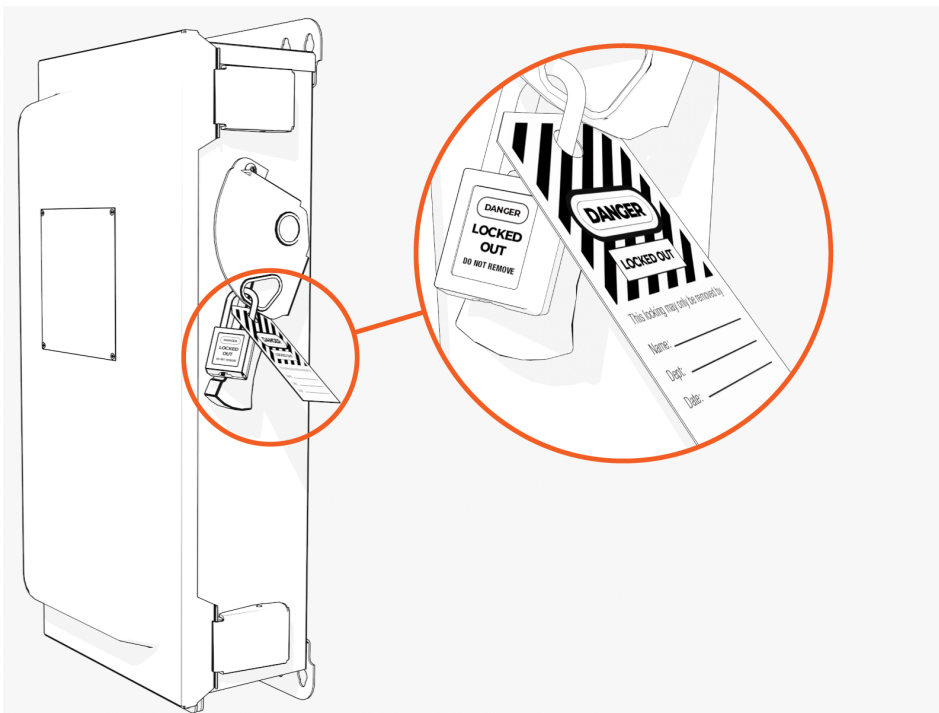

2. Use a multimeter to test that the unit is de-energized.



IMPORTANT: Do not reconnect the power after completing the installation (after installing the covers). An authorized commissioning partner will commission, power on, pinpoint, and configure Power Link 2000 after installation.

Install Power Link 2000 3

To install Power Link 2000, complete the following set of steps:



WARNING: Do not install or service the charging station in inclement weather. If you work in snow, rain, or wind, you must use a weather-proof shelter that covers all boxes and components.



CAUTION: Warranty Limitation

- If the charging station is not installed, commissioned, or serviced by a ChargePoint certified technician using a ChargePoint-approved method, it is *excluded* from all ChargePoint and other warranties and ChargePoint is not responsible.
- You must be a licensed electrician and complete training at <https://www.chargepoint.com/partners/training-certification> to become ChargePoint certified and to access ChargePoint's web-based installer tools or ChargePoint Installer app.



CAUTION: Use low torque settings when working with power tools during installation or servicing. Over-torquing can damage the equipment.



CAUTION: While installing fasteners inside a product enclosure, make sure not to drop the fasteners inside conduit openings. You may use conduit caps or covers to temporarily cover the conduit openings.



IMPORTANT: Ensure that the installation complies with all applicable codes and ordinances.

IMPORTANT: If the site has height constraints for installation, contact ChargePoint to get instructions and clearances that you will need for the modified process.



Alternatively, you may use a forklift bracket kit, or a crane with lifting shackles and a spreader bar (constraints may differ among sites).

Install Leveling Nuts

To install leveling nuts, complete the following steps:

1. If applicable, remove protective caps (x4).

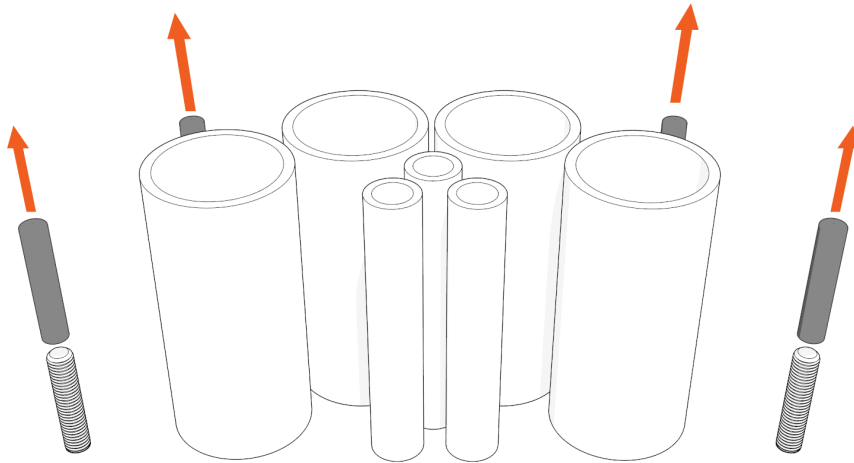

2. Clean away residue, if any.

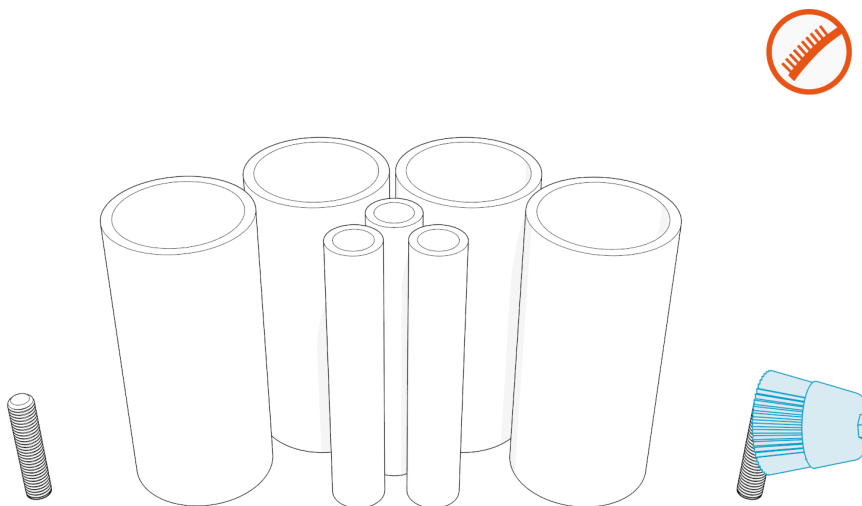

- Find the M16 hex nuts and washers shipped with the Power Link 2000.
- Install M16 washers (x4) and hex nuts (x4) onto the anchor bolts, and flush them against the base. Torque to **54.2 Nm (40 ft-lb)**.

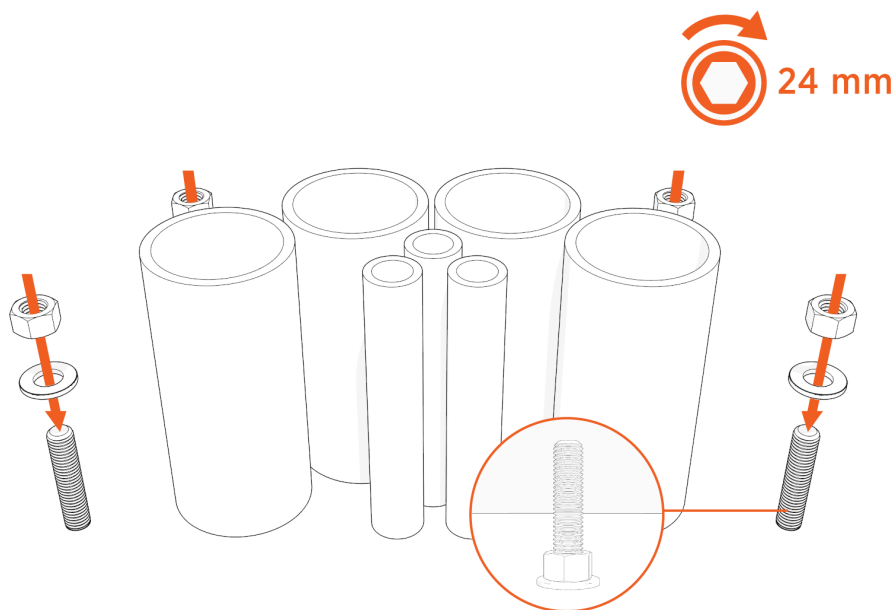

- Install another set of M16 hex nuts (x4) and washers (x4) onto the anchor bolts and leave a 6.4 mm (0.25 in) gap between the nuts for leveling the Power Link 2000.

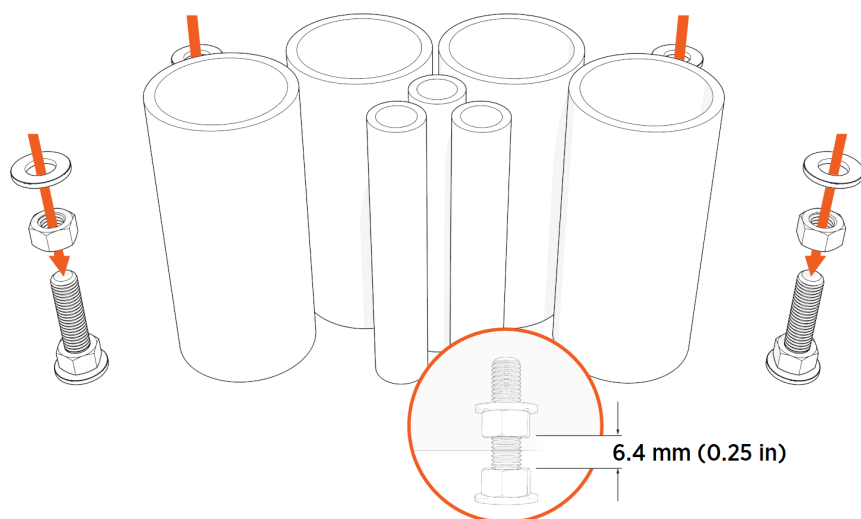

6. Ensure the nuts are level.

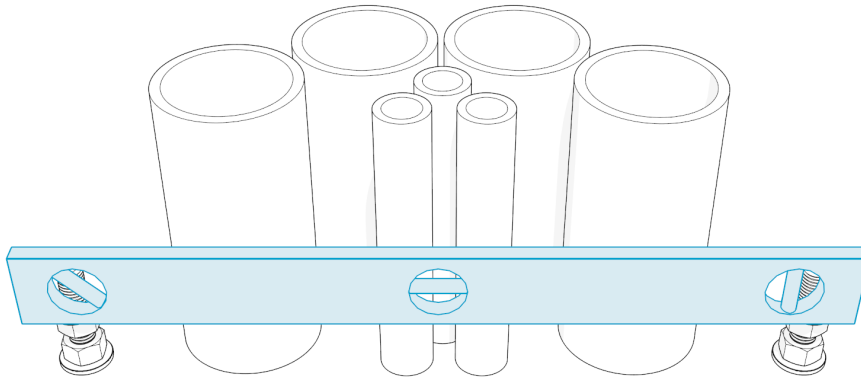

Install Power Link 2000 Assembly

To install Power Link 2000 assembly, complete the following steps:

Position Power Link 2000 Assembly over Anchor Bolts

To position Power Link 2000 assembly over anchor bolts, complete the following steps:

1. Open and unpack the Power Link 2000 package (see [Power Link 2000 with non-LCC](#) or [Power Link 2000 with LCC](#)).

2. Position the forklift to insert strap loops onto the forks. Make sure that the straps are not near the open ends of the forks. Power Link 2000 comes with straps and eye bolts attached for lifting.

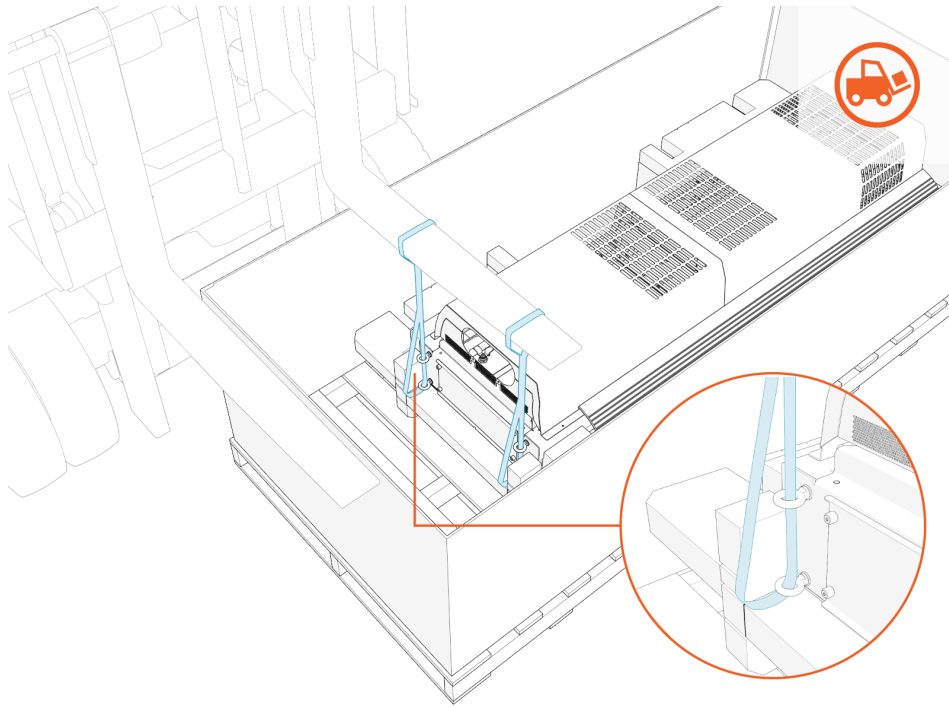

3. Gradually lift and position Power Link 2000 over the anchor bolts.

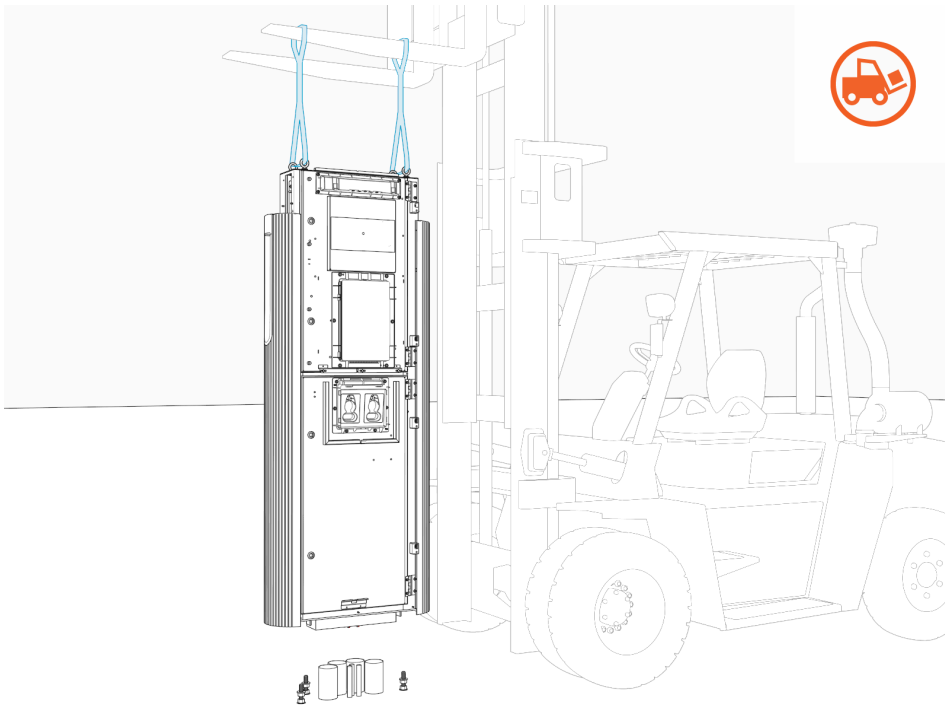

Open Enclosure Door

To open enclosure door, complete the following steps:

1. Quarter turn the door latches (x2 per upper and lower enclosure door).

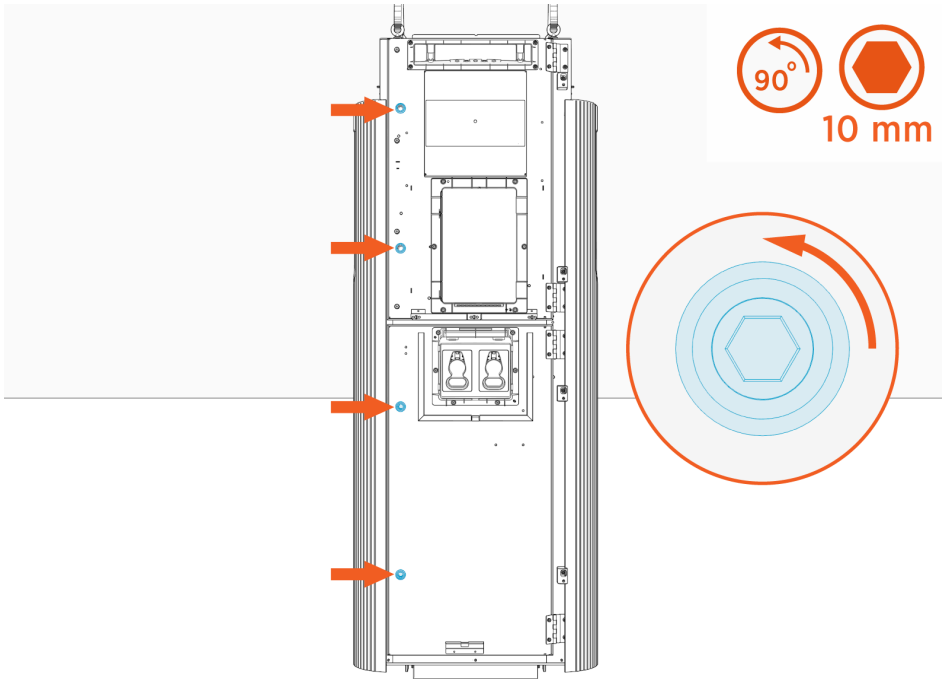

2. Open the door and engage the door stopper (x1 per upper and lower enclosure door).

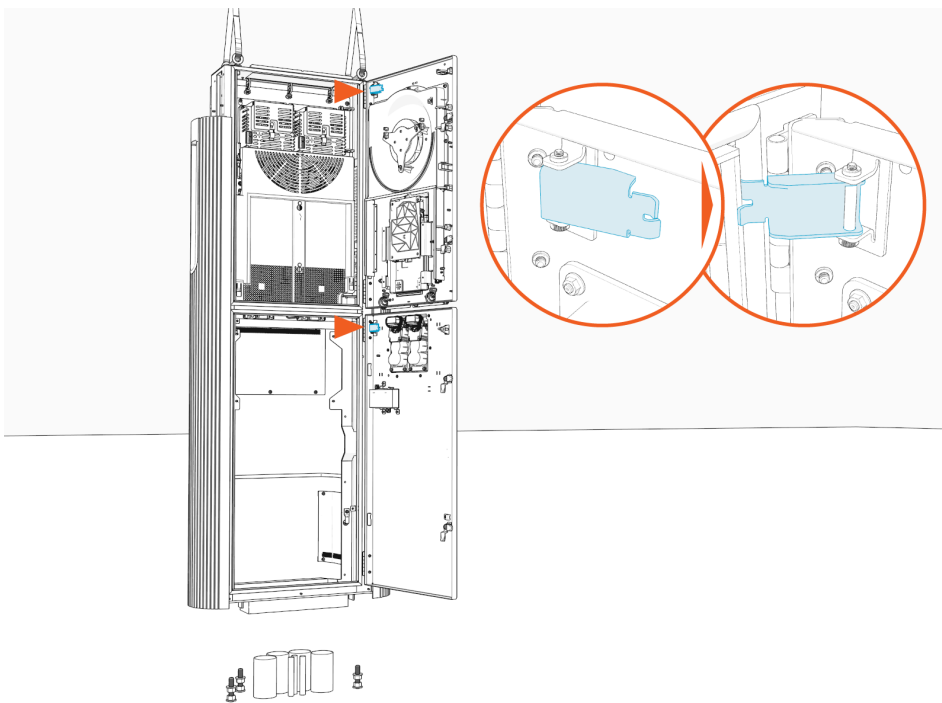

Install Power Link 2000 onto Anchor Bolts

To install Power Link 2000 onto anchor bolts, complete the following steps:

1. Align the anchor bolt holes (x4) on the Power Link 2000 with the anchor bolts and slowly move the Power Link 2000 down to rest it on the leveling nuts.



IMPORTANT: If the wires have been pulled before mounting the Power Link 2000 or if the site is using armored cables directly buried and exposed from underground without conduits, route wires through conduit opening at the bottom of the Power Link 2000.

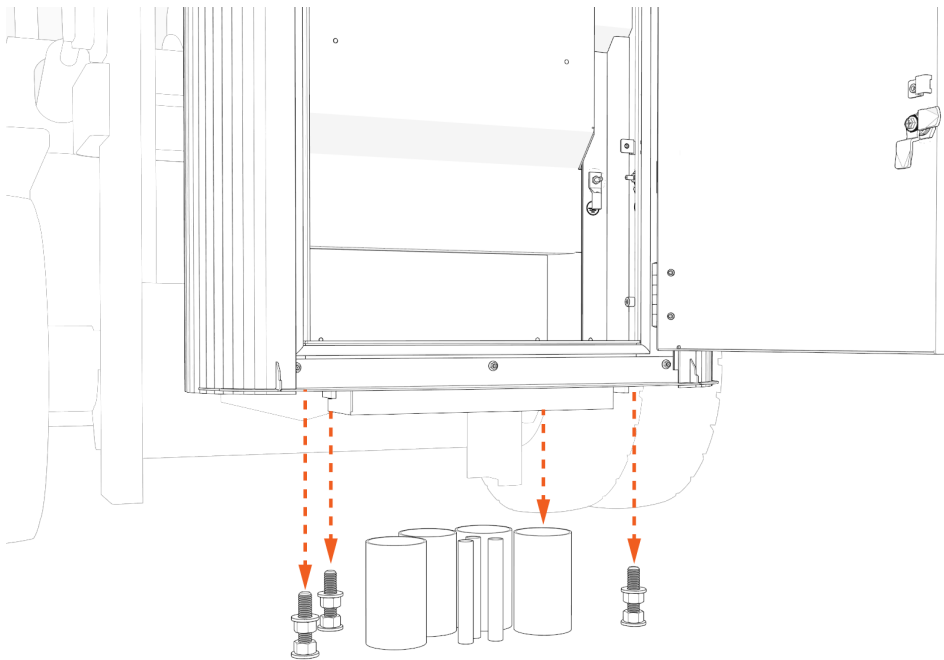

2. Make sure that the Power Link 2000 is resting on the leveling nuts and is level and plumb. If not, adjust the leveling nuts.

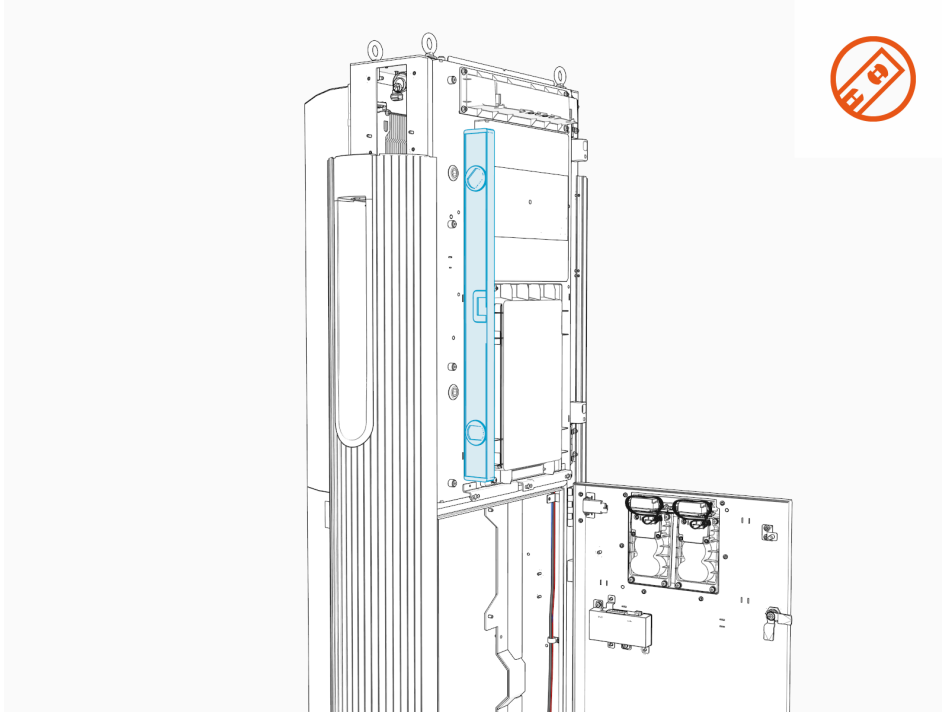

3. When the Power Link 2000 is level and plumb, install another set of M16 washers (x4) and hex nuts (x4) onto the anchor bolts. Torque to **94.9 Nm (70 ft-lb)**.

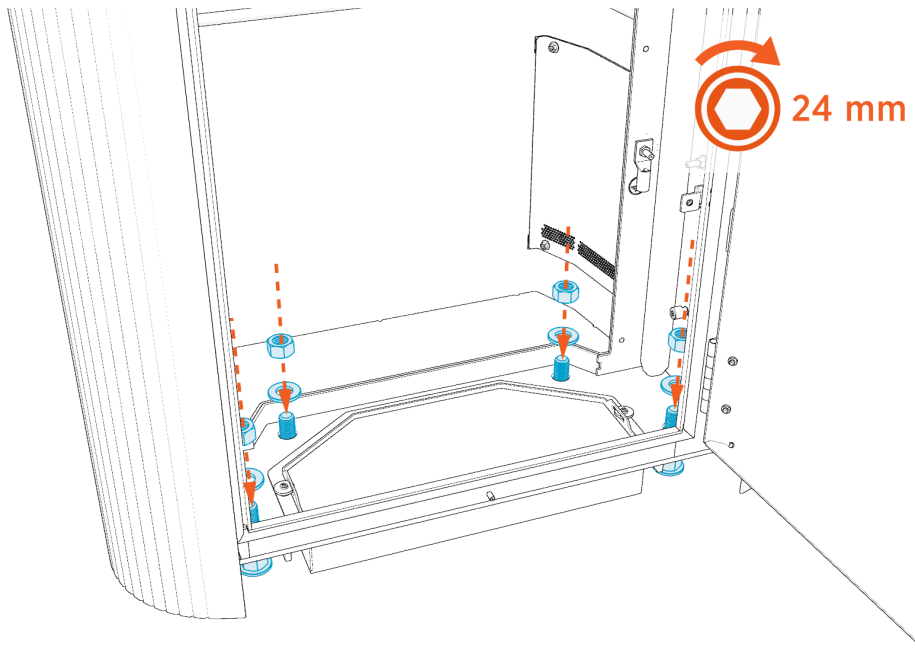

4. Release the lifting straps, and remove the eye bolts (x4) and rubber washers (x4). Use either an adjustable wrench or screwdriver shaft to loosen the eye bolts.

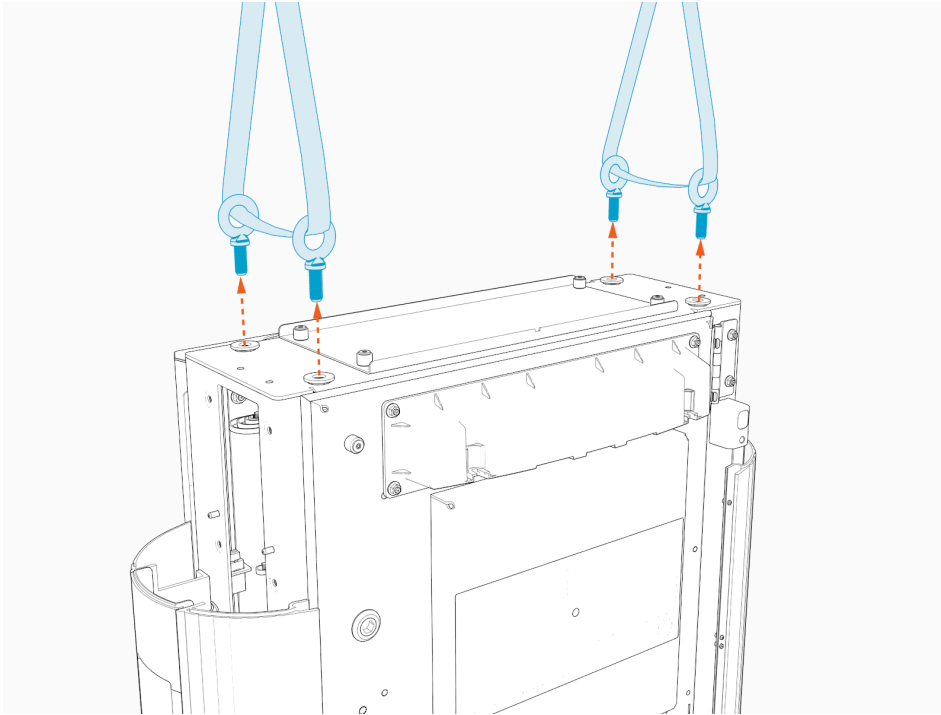

If wires shall enter the Power Link 2000 by surface conduit entry, install the Surface Conduit Entry (SCE) Kit. See [Appendix: Surface Conduit Entry Kit Installation](#).

Access DC Wire Bus Bars and Terminals

To access the DC wire bus bars and terminals in the upper cabinet, complete the following steps:

1. Open the upper door.
2. Slide the bus bar safety cover up to remove from the hooks (x2) and brackets (x2).

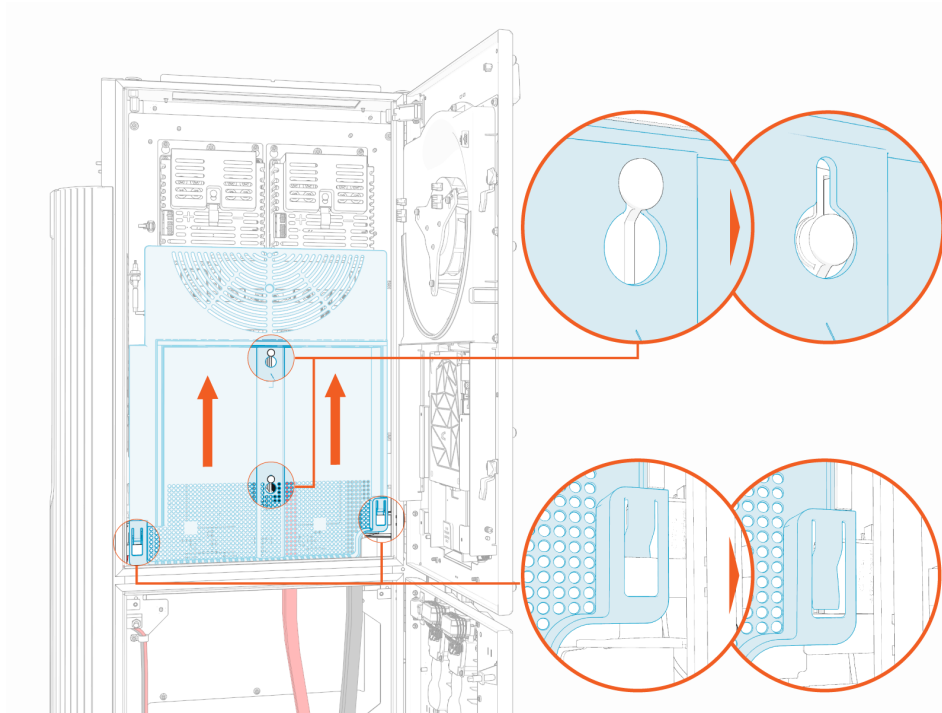

Plan for DC Power Path Wire Connect

The physical locations for landing DC power path and ground wires are shown below.

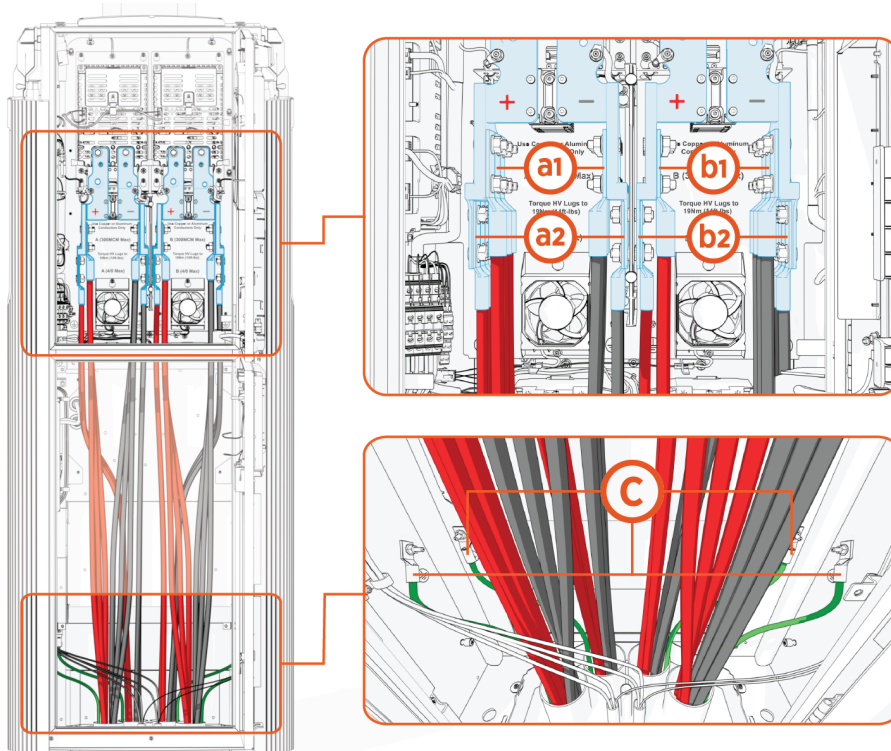

- (a1) Power Path A, upper landing
- (a2) Power Path A, lower landing
- (b1) Power Path B, upper landing
- (b2) Power Path B, lower landing
- (c) Ground



NOTE: In this guide, "ground" refers to Protective Earth (PE).

Depending on its configuration, a Power Link 2000 will have one or two independent DC power paths, Power Path A and Power Path B. Power Link 2000s with a single charging cable are configured with Power Path B only.

The upstream power cabinet provides multiple independent DC outputs, and any of these outputs may be connected to either Power Link 2000 power path. The letter labels on the upstream outputs (such as EXT A and EXT B) do not need to match the Power Link 2000 power path labels. For example, an upstream DC output labeled EXT A may be connected to either Power Path A or Power Path B.

How exactly to make connections within a cluster of power cabinets and Power Link 2000s is determined by the Express architecture chosen for the site. Use the site plan single line diagram to understand and plan how to land the wires on the Power Link 2000 DC power path landings. If you require further assistance in this matter, go to chargepoint.com/support and find your region's technical support number.

Pull, Cut, and Connect Wires

To pull, cut and connect wires, follow the instructions below:

DC Power Path Wires

1. Label the DC power path and ground wires at both ends.
2. Pull wires through the conduits. See [How to Pull DC Power Path Wires](#).

IMPORTANT:



- In regions that use conduits, wires can be pulled before or after mounting the Power Link 2000. Skip this step if the wires have been pulled before mounting or if the site is using armored cables directly buried and exposed from underground without conduits.
- Illustrations in this guide depict a Power Link 2000 with two rear conduits and two front conduits. The actual quantity and arrangement of conduits will vary by site.
- Pull wires through the rear conduits first. Pulling wires through the front conduits restricts access to the rear conduits.

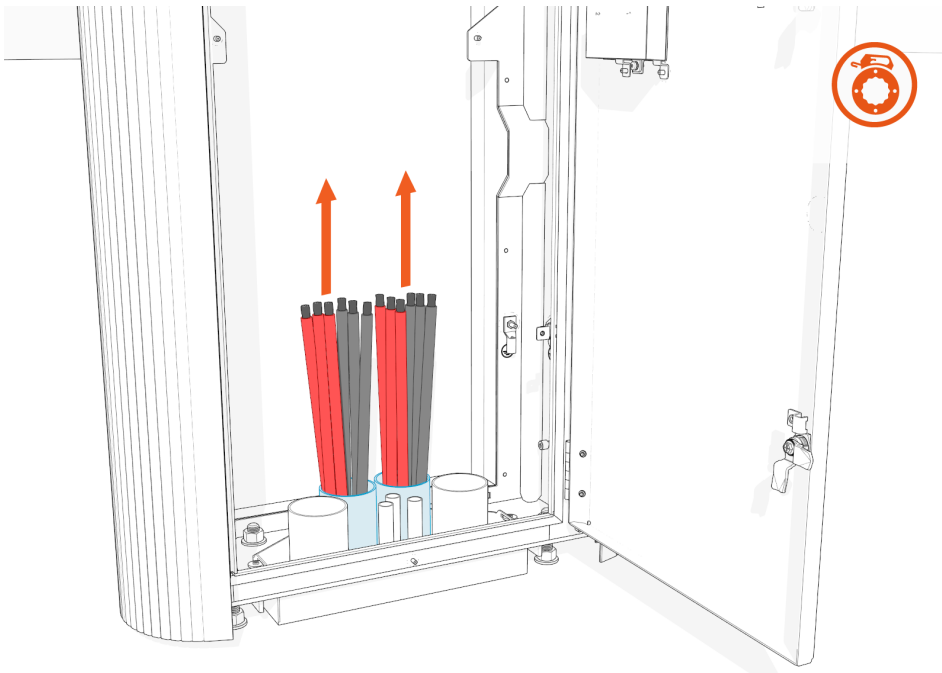

3. Arrange wires so they reach the DC power path landings with as little bend as possible. Cut wires to length, taking into account the terminating lug length.

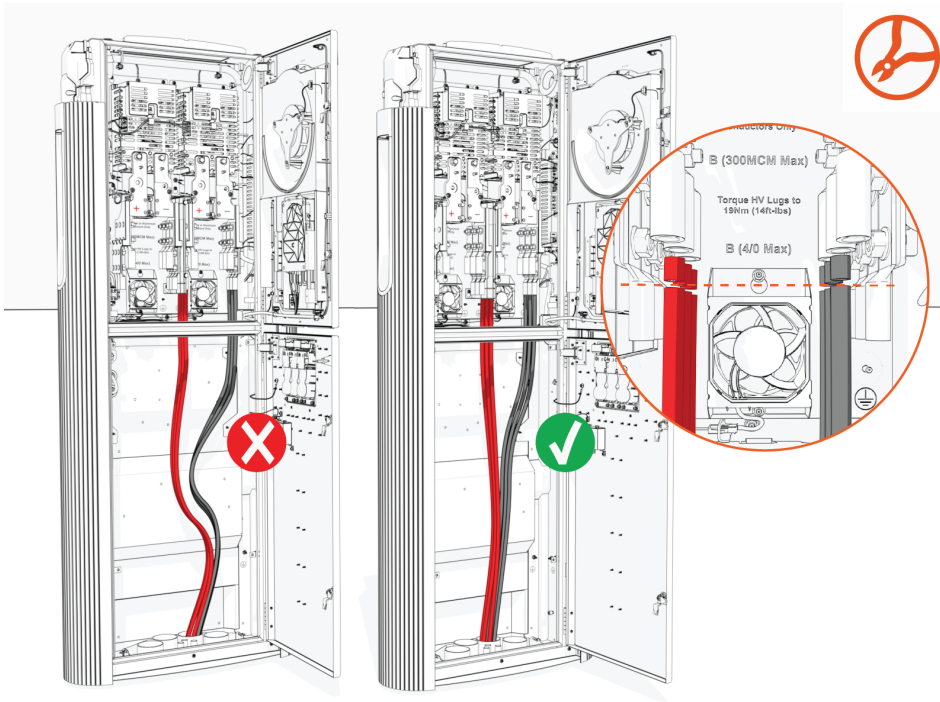

4. Perform insulation resistance test on the DC power path wires. Refer to the *High Voltage Wire Insulation Resistance Test Field Guide*.

5. Connect the DC power path and ground wires. See [How to Connect DC Power Path and Ground Wires](#).



IMPORTANT: Connect wires starting at the lower landings. Landing wires at the upper landings restricts access to the lower landings.

- a. Connect wires starting at lower landings.

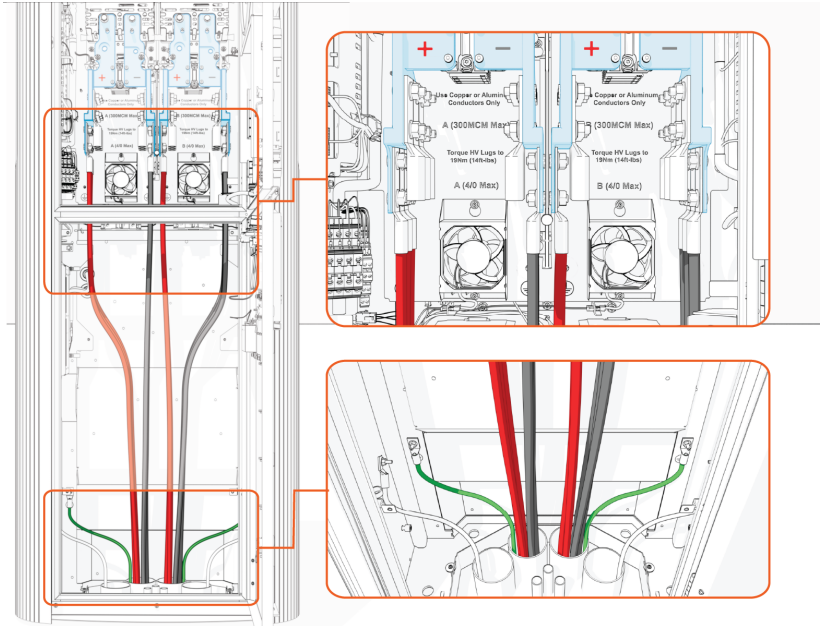

- b. Connect wires at upper landings after lower landings are populated.

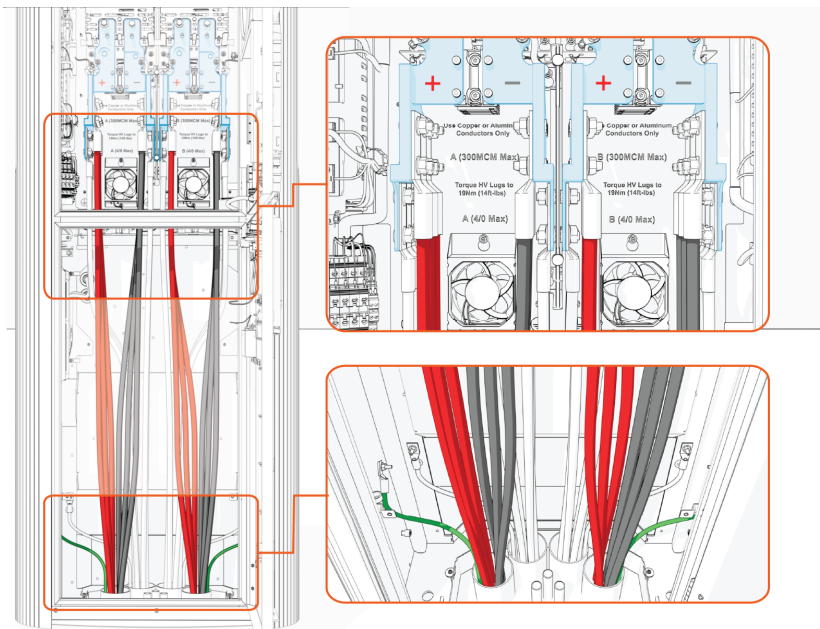

48 V DC and Ethernet Wires

1. Label the 48 V DC and Ethernet wires at both ends.
2. Pull the 48 V DC wires and Ethernet cables through the conduits.

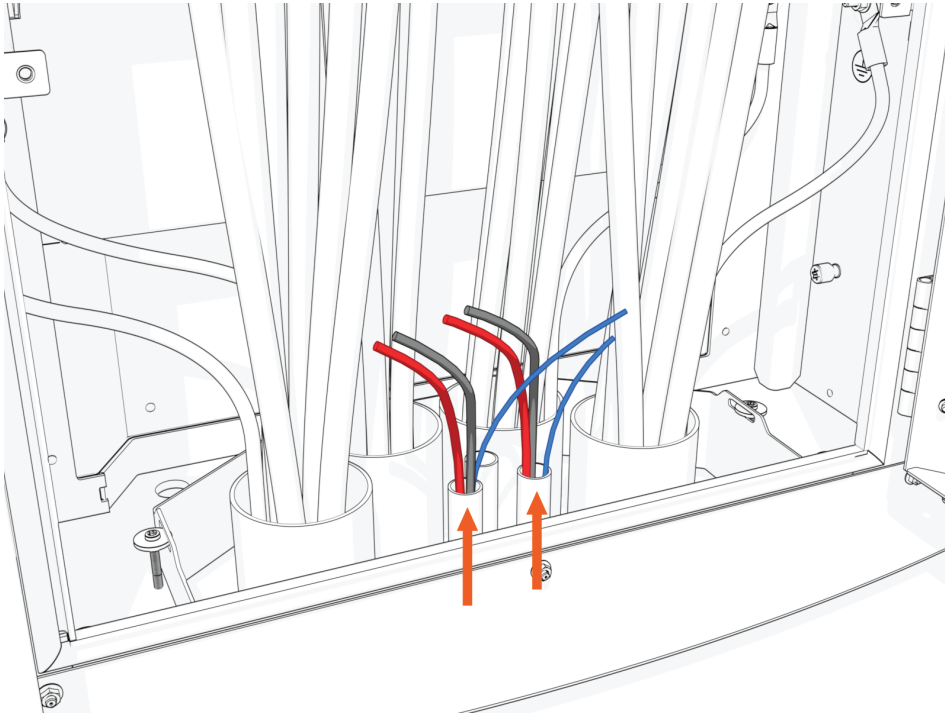

3. Connect the 48 V DC wires and Ethernet cables. See [How to Connect 48 V DC and Ethernet Wires](#).

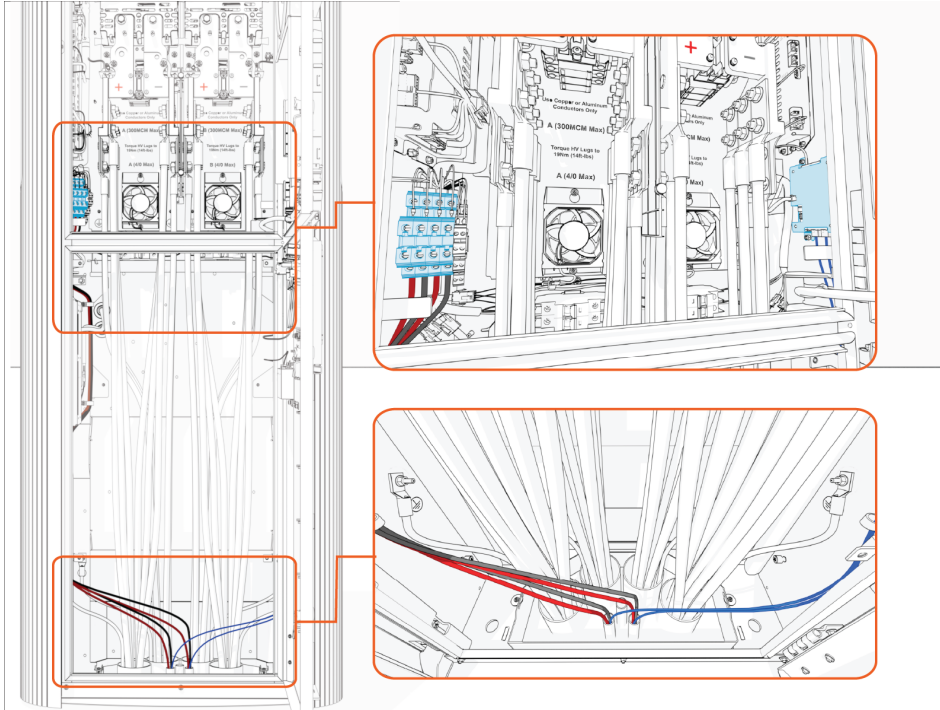

How to Pull DC Power Path Wires

To pull the DC power path wires, complete the following steps:

1. Arrange wires such that the positive wires (red) arrive on the left side and negative wires (black) arrive on the right side within the Power Link 2000. This arrangement will help you land wires on their respective poles.

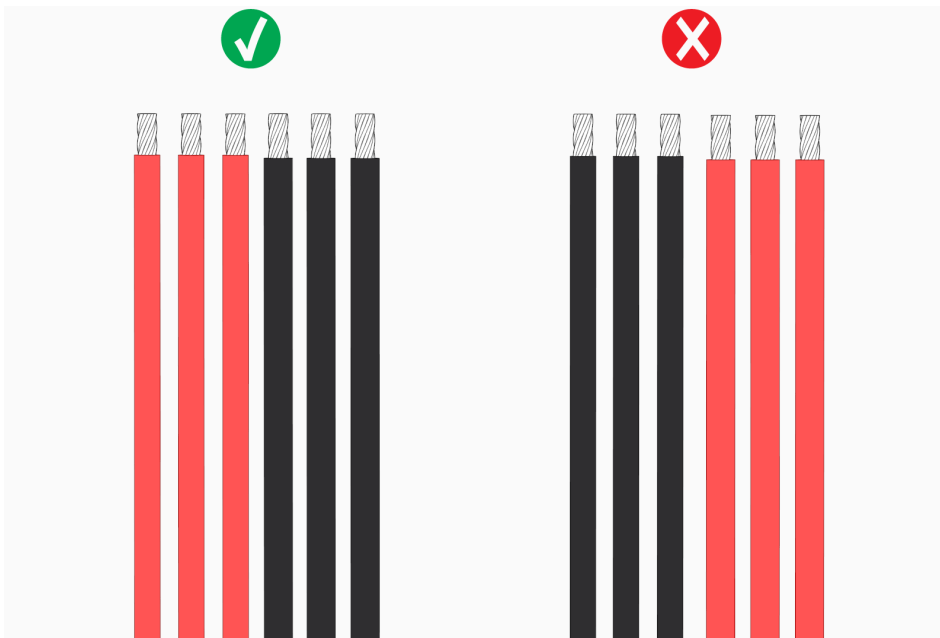

2. If necessary, apply a non-conductive wire pulling lubricant.
3. Pull the wires.
4. Wipe off any remains of wire pulling lubricant if applied.

How to Connect DC Power Path and Ground Wires

IMPORTANT: Before you begin, make note of the following:



- Refer to the *Express Distro Power Link 2000 Site Design Guide* for the wire and lug specifications.
- Make sure no bare conductor is exposed below the lug's barrel. If necessary, heat shrink or tape the exposed area to meet the local code requirements.
- Wipe off any remains of wire pulling lubricant if applied.

Prepare DC Power Path Wires

To prepare DC power path wires, complete the following steps:

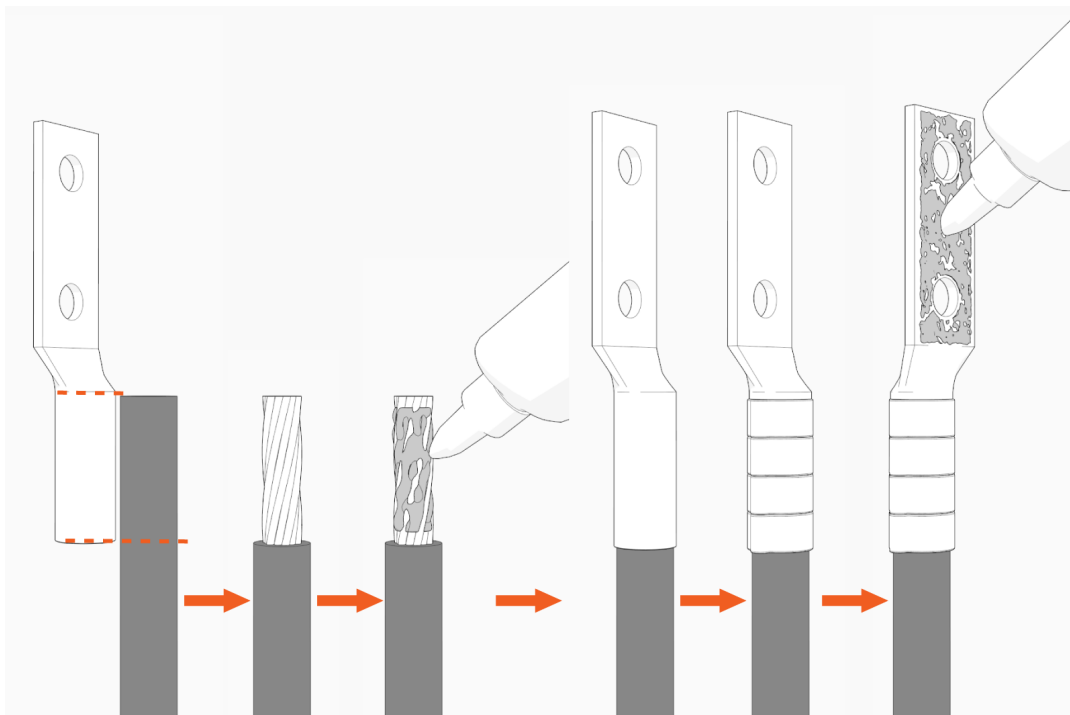

1. Mark the lug's barrel height on the wire terminal.
2. Strip the jacket on the marked terminal. Use a suitable wire stripper, such as Klein tool.
3. If recommended by the wire manufacturer or local code, apply an anti-oxidant joint compound to the stripped wire material to make a gastight joint with the lug.
4. Insert the stripped terminal into the lug's barrel and crimp it. Use a suitable lug crimping tool and/or die recommended by the lug manufacturer.
5. Apply dielectric grease to the lug's tongue surface that comes in contact with the bus bars.

Connect DC Power Path Wires

To connect the DC power path wires, complete the following steps:

1. Identify the location for landing one wire. See [Plan for DC Power Path Wire Connect](#) for the wire landing locations.
2. Remove lug nuts.

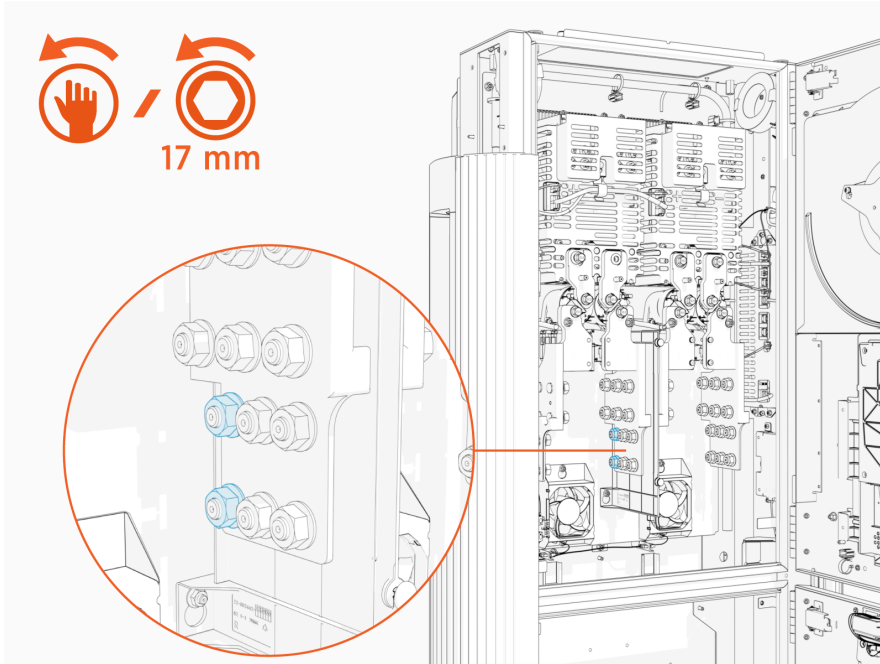

3. Install the prepared wire onto the studs.



IMPORTANT: Maintain correct polarity. Install the red (+) conductors on the bus bars labeled "+" and the black (-) conductors on the bus bars labeled "-".

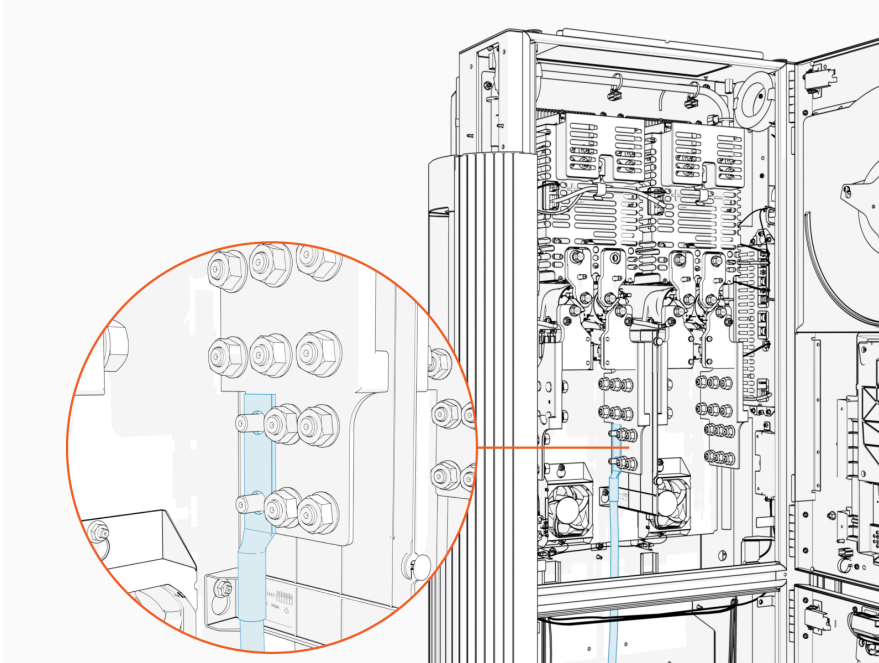

4. Reinstall the lug nuts and torque them.



IMPORTANT: Torque the lug nuts to **19 Nm (14 ft-lb)**.

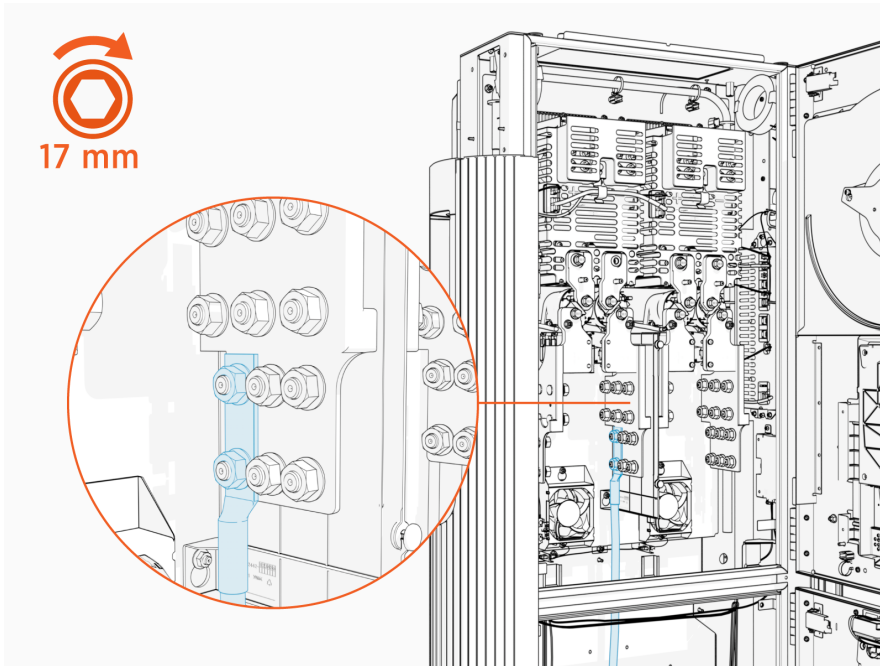

5. Repeat for all remaining DC power path wires.

6. Mark all torqued connections to indicate all lug nuts have been tightened. Torque marks are required to pass post-installation inspection.

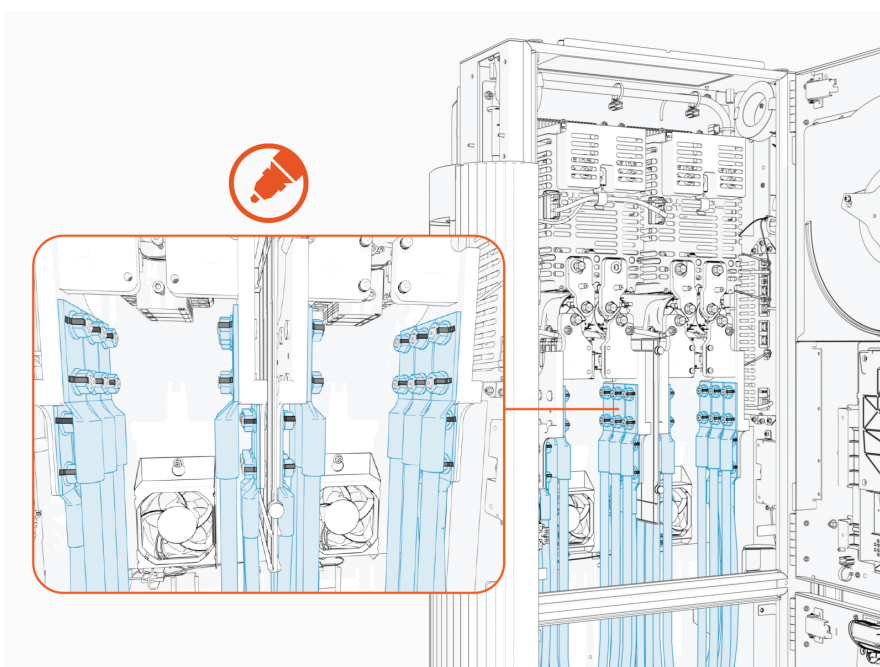

Prepare Ground Wires

To prepare ground wires, complete the following steps:

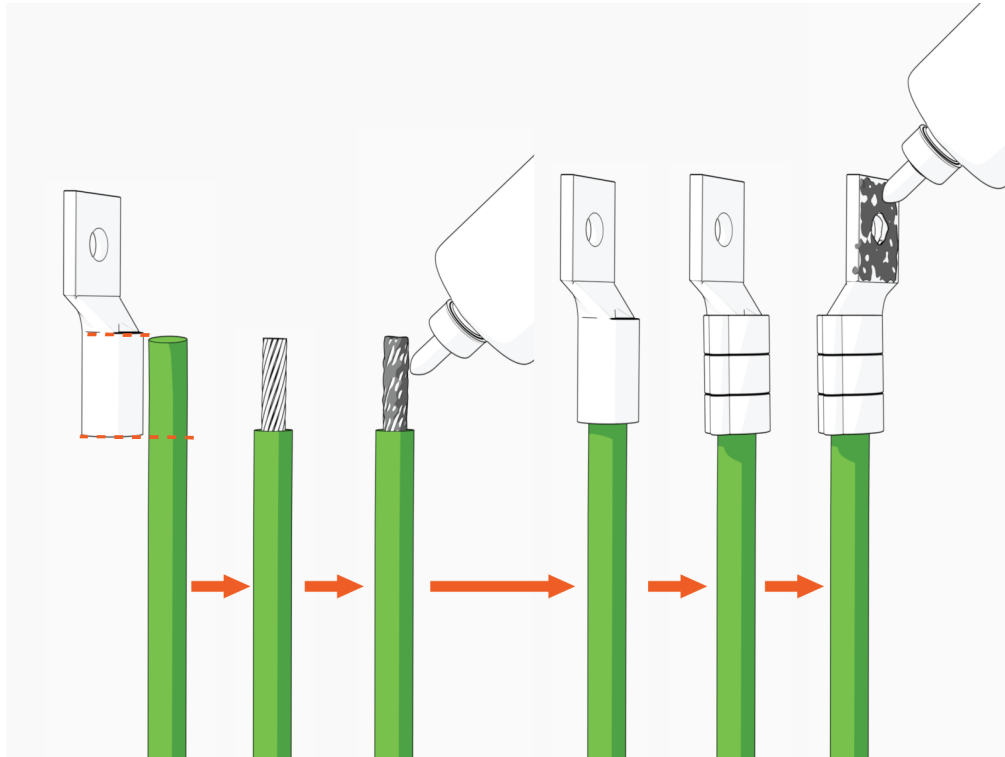

1. Mark the lug's barrel height on the wire terminal.
2. Strip the jacket on the marked terminal. Use a suitable wire stripper, such as Klein tool.
3. If recommended by the wire manufacturer or local code, apply an anti-oxidant joint compound to the stripped wire material to make a gastight joint with the lug.
4. Insert the stripped terminal into the lug's barrel and crimp it. Use a suitable lug crimping tool and/or die recommended by the lug manufacturer.
5. Apply dielectric grease to the lug's tongue surface that comes in contact with the bus bars.

Connect Ground Wires

To connect ground wires, complete the following steps:

1. Identify a target ground wire landing stud. See [Plan for DC Power Path Wire Connect](#) for the wire landing locations.



NOTE: Two ground wires may land on a single stud by stacking the wires on the stud. This is necessary when there are more than four ground connections that must be made.

2. Remove lug nut.

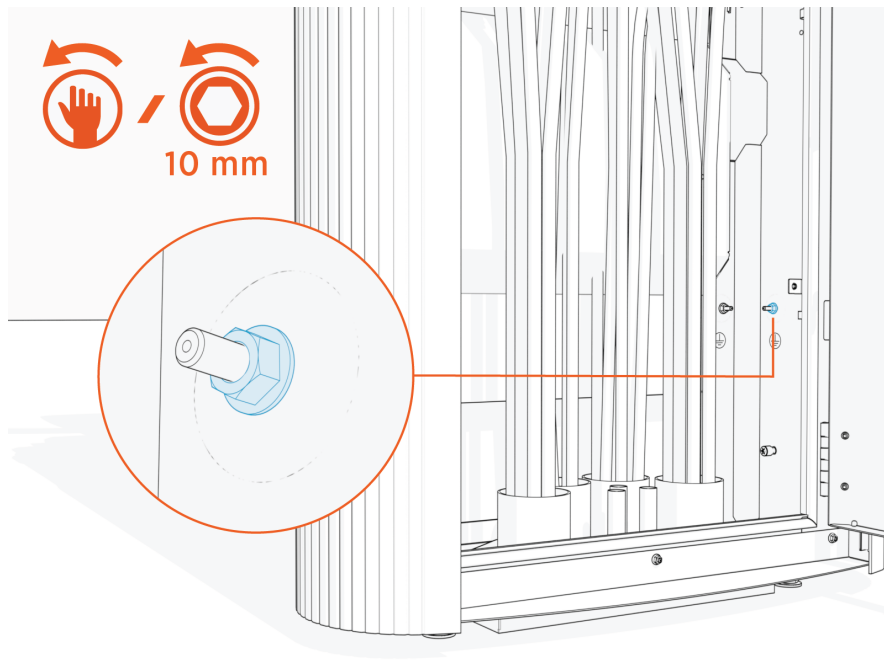

3. Install the prepared wire onto the stud.

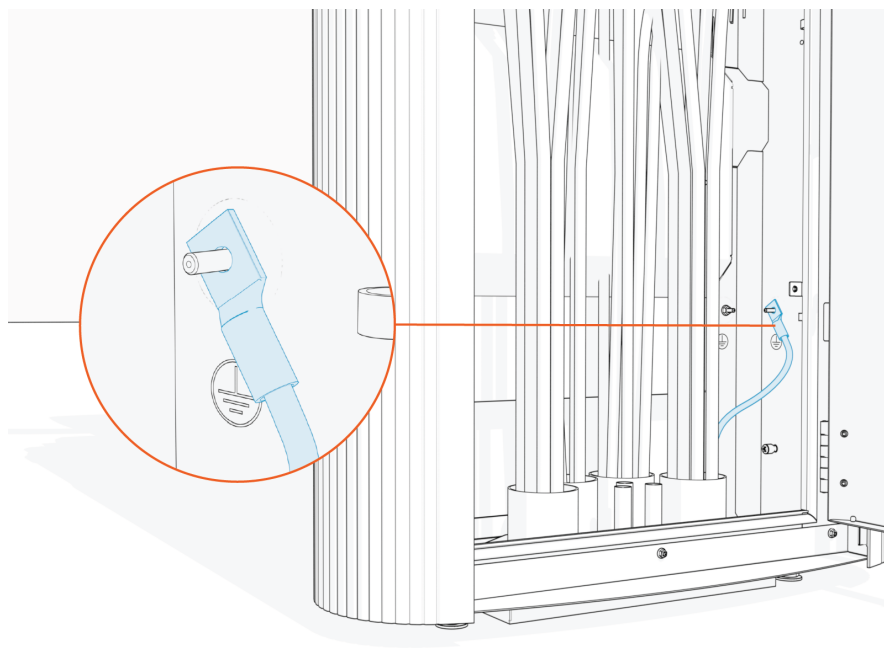

4. Reinstall the lug nut and apply torque.

! **IMPORTANT:** Torque the ground wire lug nut to **5.6 Nm (50 in-lb)**.

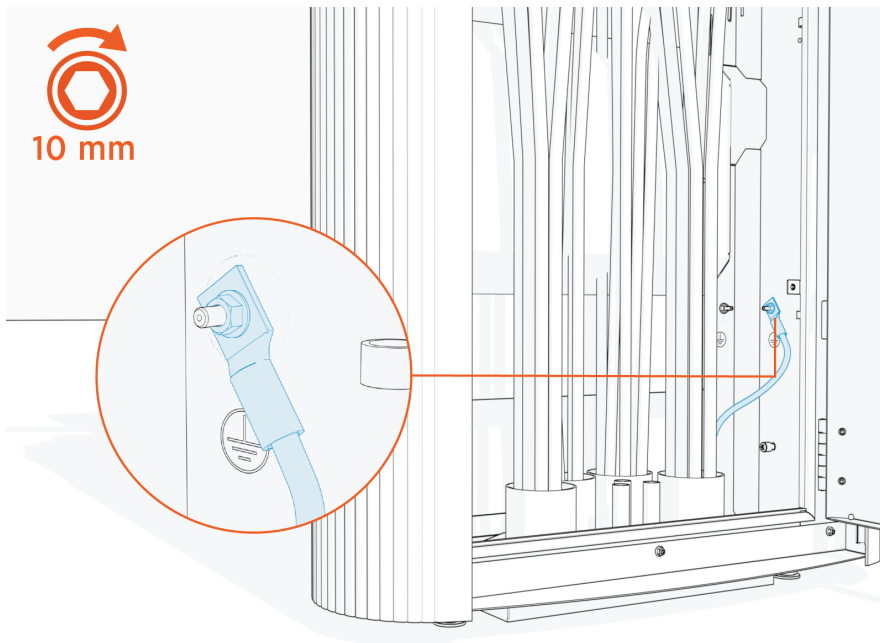

5. Repeat for all remaining ground wires.
6. Mark all torqued connections to indicate all lug nuts have been tightened. Torque marks are required to pass post-installation inspection.

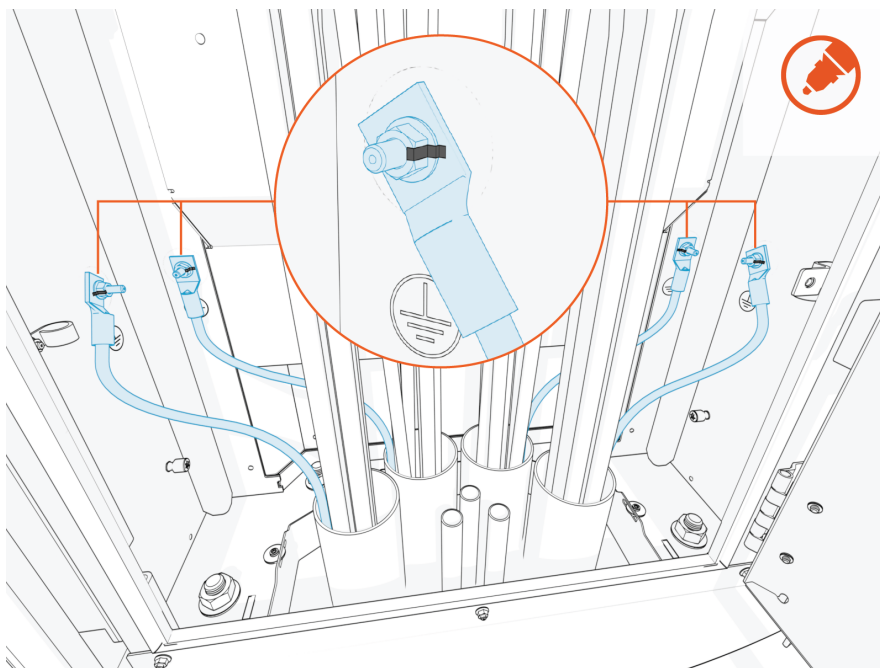

How to Connect 48 V DC and Ethernet Wires

To connect 48 V DC and Ethernet wires, follow the instructions below:

Connect 48 V DC Wires

Follow the procedure below for each 48 V DC wire pair.

1. On the 48 V terminal block, identify the target wire insertion points for landing the 48 V DC wire pair.



IMPORTANT: If the wire terminals do not appear as pictured here, you are using the wrong installation guide. See [About This Guide](#) for more information.

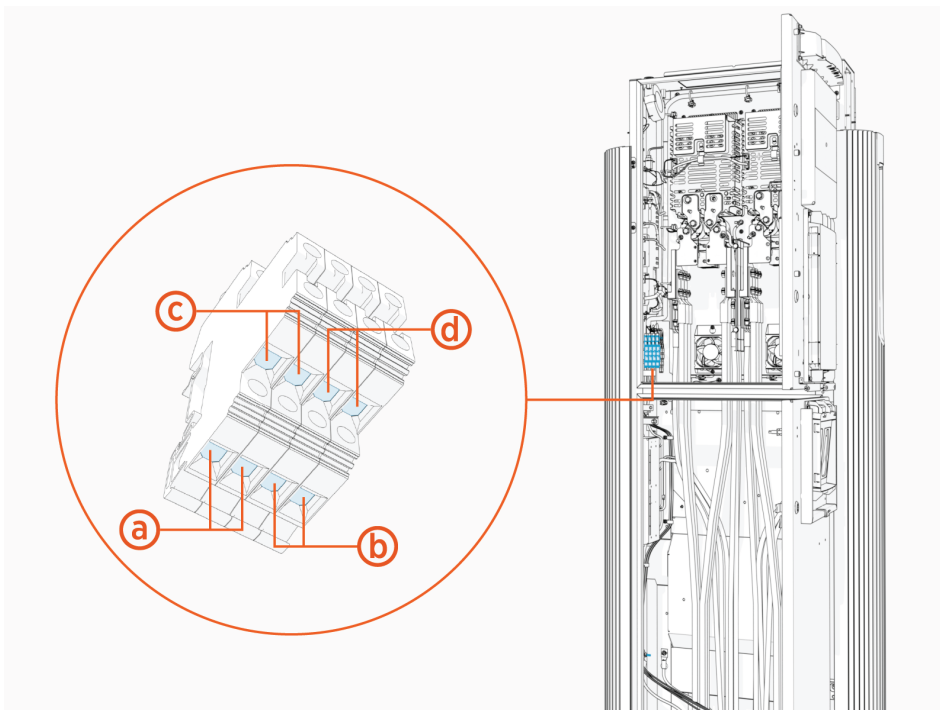

- (a) 48 V DC input, primary
- (b) 48 V DC input, secondary
- (c) 48 V DC output, primary
- (d) 48 V DC output, secondary

- Strip the wire jackets (x2). If using wire ferrules, install the ferrules after stripping the conductors.

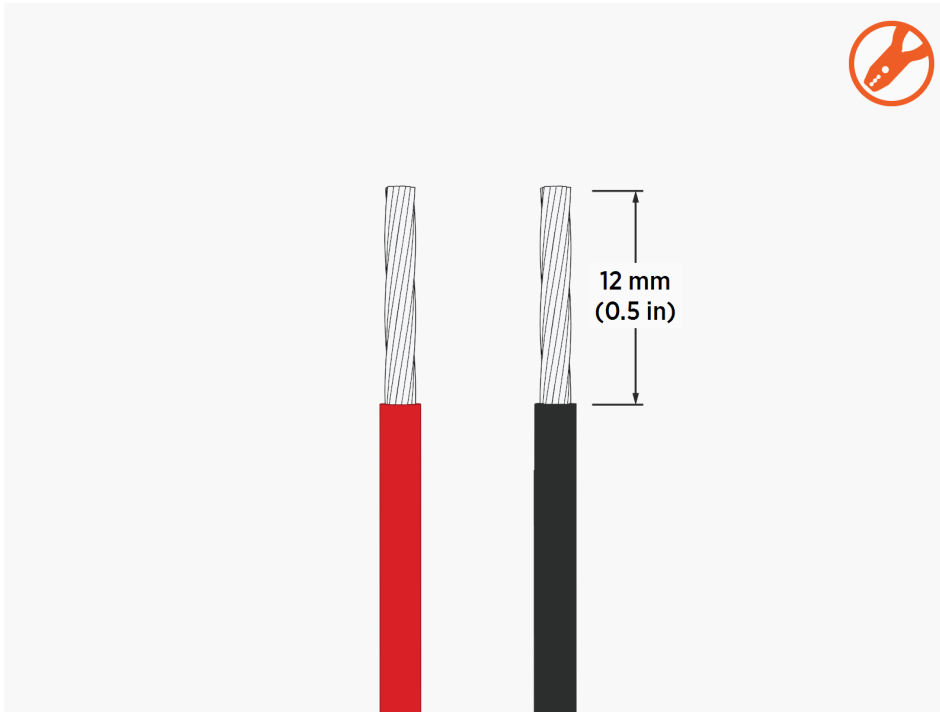

3. Loosen the wire set screws (x2).

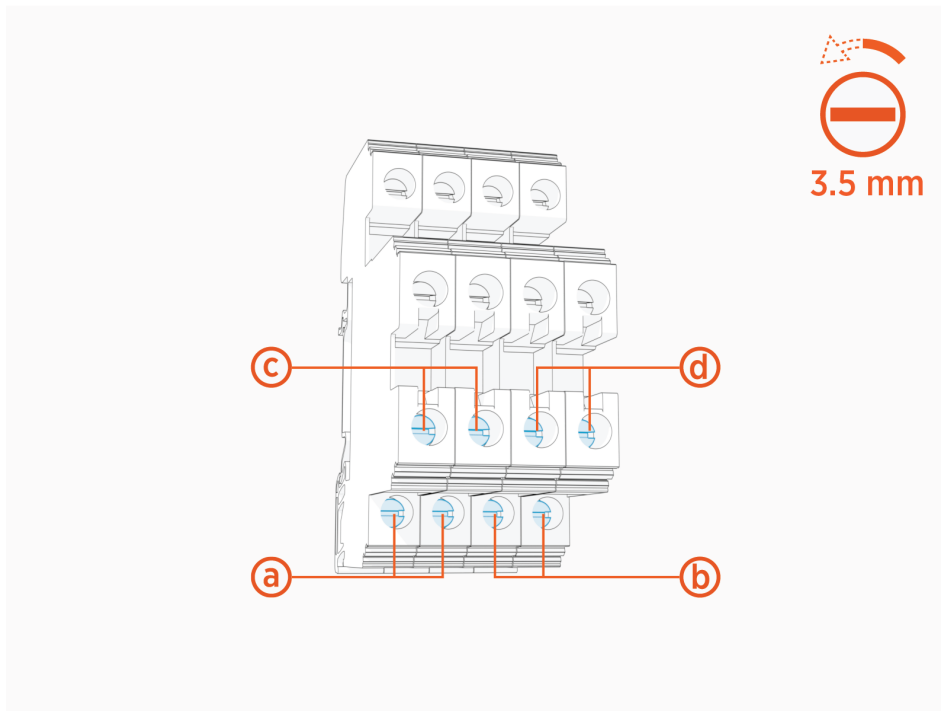

- (a)** 48 V DC input, primary
- (b)** 48 V DC input, secondary
- (c)** 48 V DC output, primary
- (d)** 48 V DC output, secondary

4. Route wires (x2) through the wireway clamps (if necessary use cable ties) and insert them into the terminal block.



IMPORTANT: Insert the positive (+) wire into the left terminal. Insert the negative (-) wire into the right terminal. The illustration below depicts insertion of the primary 48 V DC input wire pair.

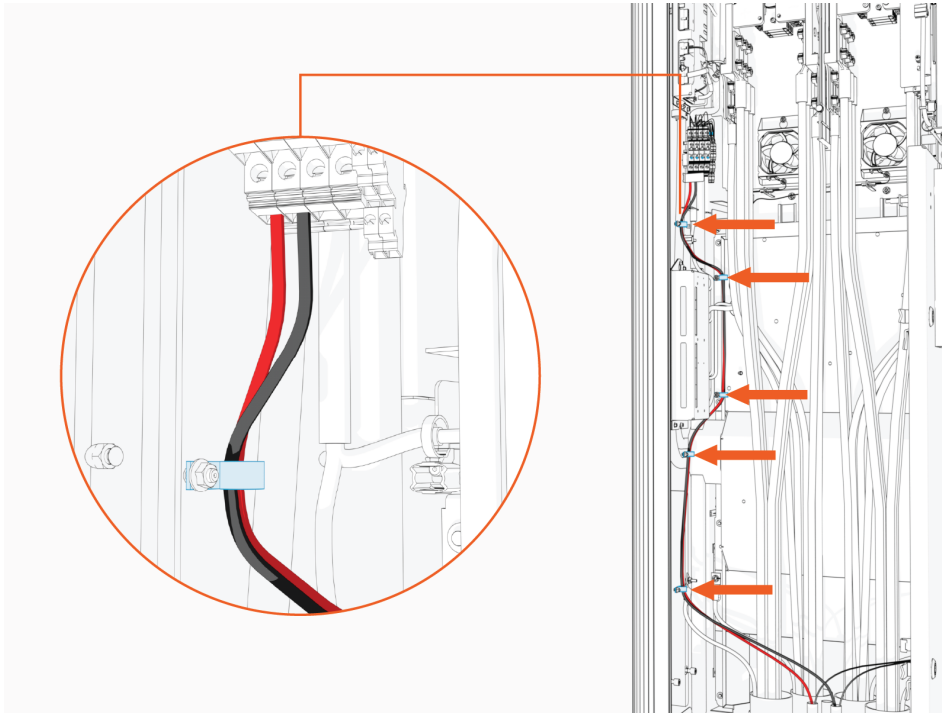

5. Torque the screws (x2) to **1.5 Nm (13.3 in-lb)**. Push-pull to test that both (+ and -) wires are secured.

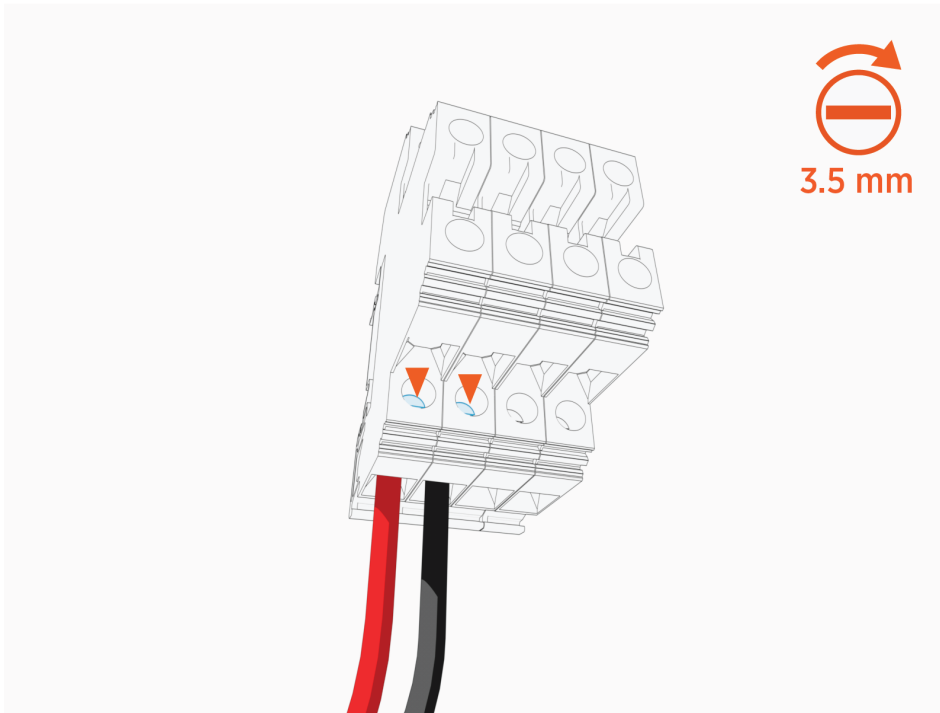

Connect Ethernet Cables

Follow the procedure below to connect each Ethernet cable.

1. On the Smart Ethernet Switch, locate three ports for landing Ethernet cables. All ports are equivalent.



IMPORTANT: If the wire terminals do not appear as pictured here, you are using the wrong installation guide. See [About This Guide](#) for more information.

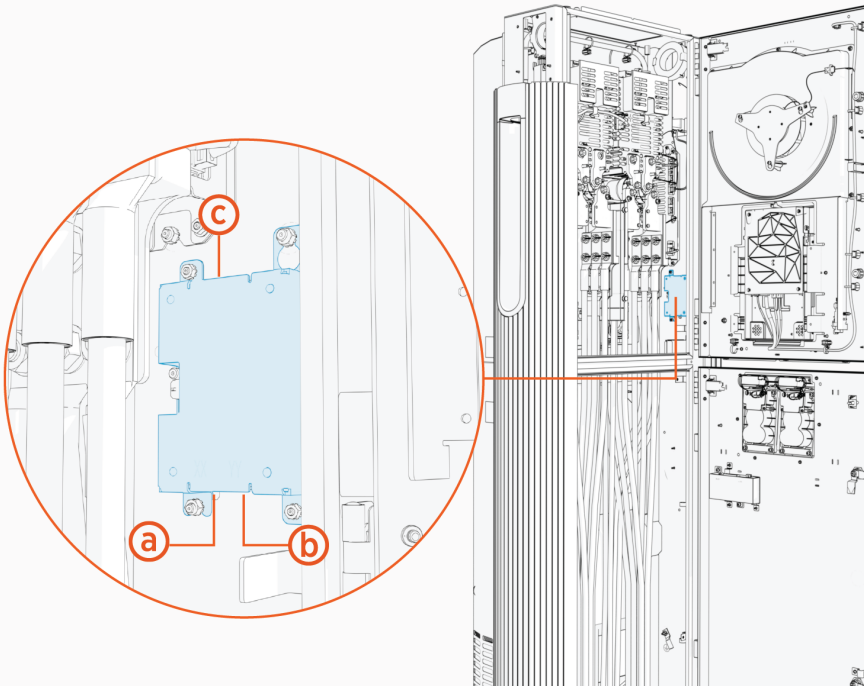

- (a) Lower left port
- (b) Lower right port
- (c) Upper port

2. Trim Ethernet (Cat6 STP) cable to length, allowing for a service loop.

3. Field crimp a shielded RJ45 connector onto the Ethernet cable. Use straight-through T568B pattern.

IMPORTANT: Ground the Ethernet cable shield as follows:



- For an Ethernet cable connecting from a power cabinet to Power Link 2000, ground the shield at the power cabinet cable end. Do not ground the shield at the Power Link 2000 cable end.
- For an Ethernet cable connecting between Power Link 2000s, ground the shield at the cable end nearer to the power cabinet (per Ethernet topology for the Express cluster). Do not ground the shield at the other cable end.

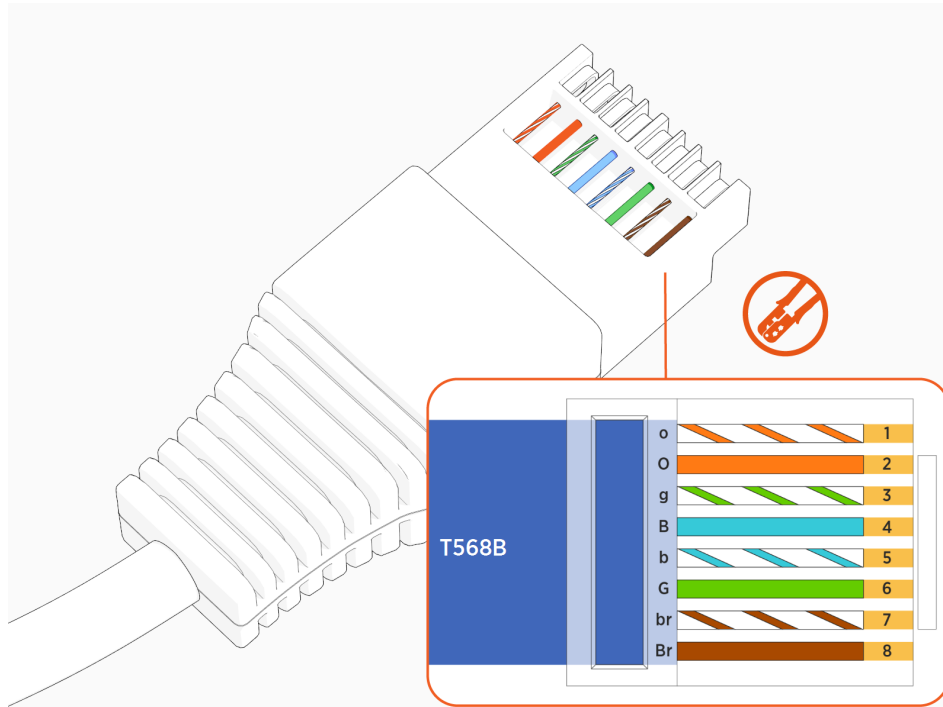

4. Test the Ethernet cable for functionality.



IMPORTANT: If using a Paige OSP Shielded GameChanger cable for a wire run length greater than 100 m (328 ft), follow the test procedure specified by Paige. See [Paige GameChanger Resources](#).

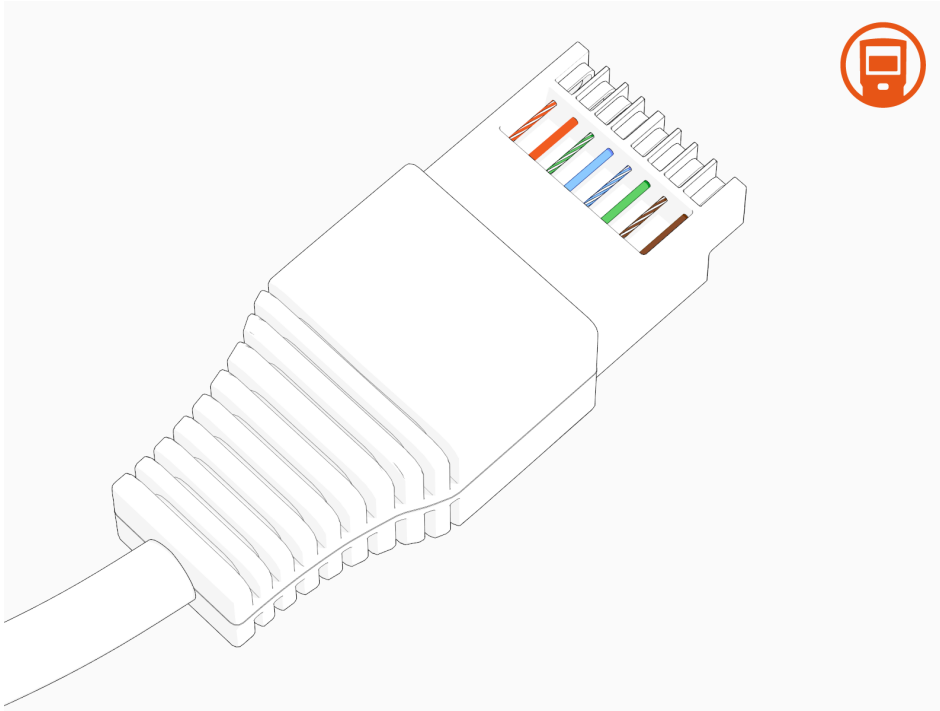

5. Route the cable through the wireway clamps and connect to any available port on the Smart Ethernet Switch. To establish a secure connection, the RJ45 connector's latch must click into the switch.

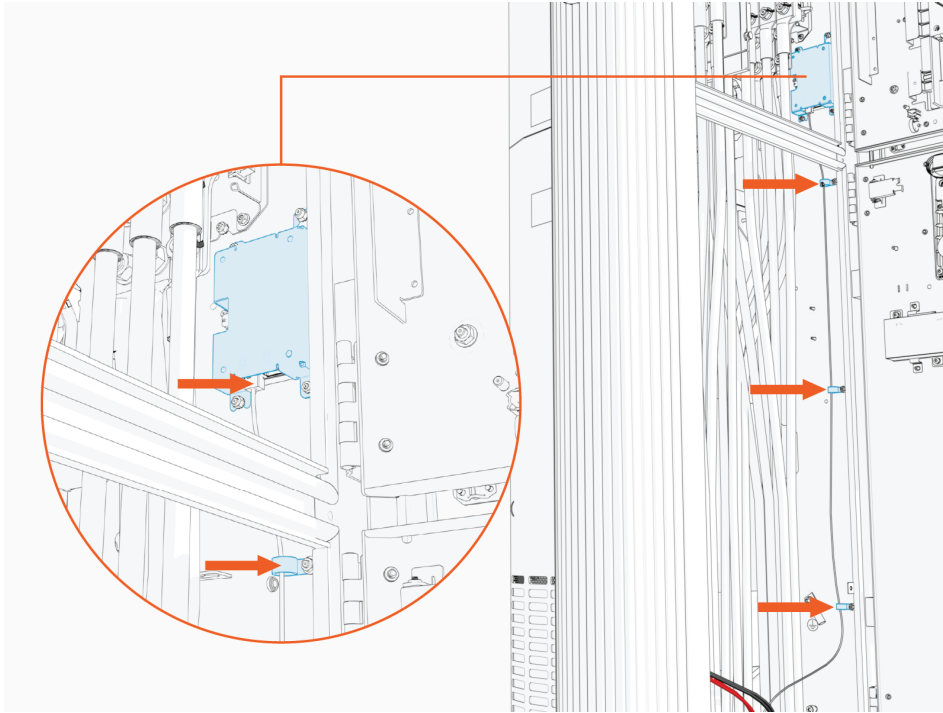

Complete Additional **4** Configurations

Some Power Link 2000 deployments require additional configuration steps or optional kits. Complete only the sections that apply to the Power Link 2000 configuration you are installing.

Install Ethernet to USB Kit

If the site plan indicates the Power Link 2000 must be configured with a hardwire Ethernet connection to a network server, follow procedures in this section to install the Ethernet to USB Kit and the hardwire connection.

1. Unpack the Ethernet to USB Kit. Confirm all parts listed below are present.



NOTE: For any missing component, contact chargepoint.com/support.

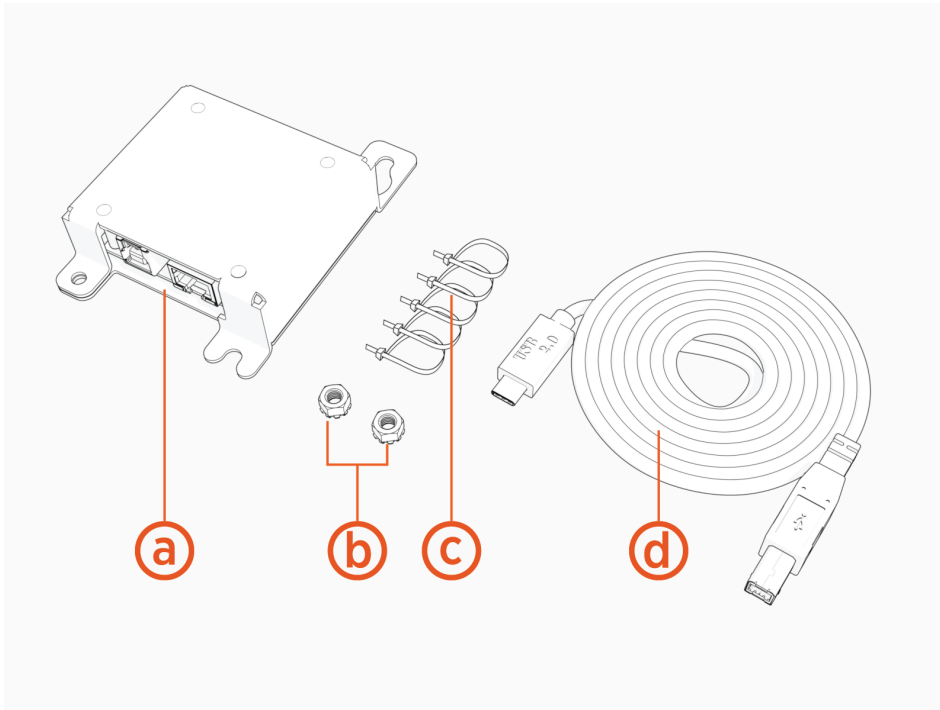

- (a)** Ethernet to USB module
- (b)** M5 star washer nuts (x2)
- (c)** Zip ties (x5)
- (d)** USB 3.0 Type B to Type C cable

2. Locate the mounting studs (x2).

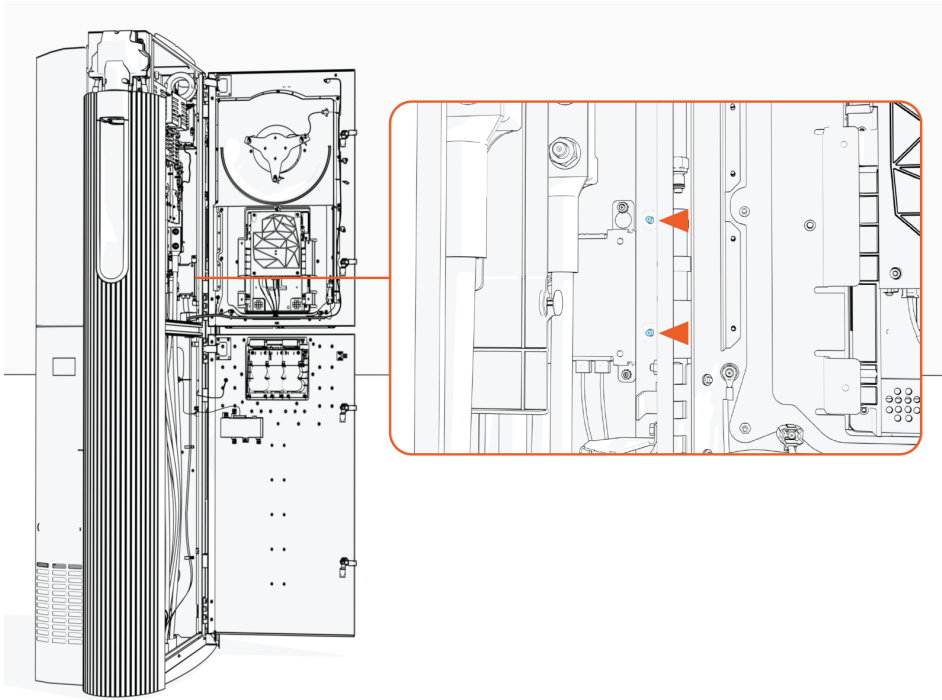

3. Install M5 star washer nuts (2) partially onto the studs. Thread the nuts only halfway onto each stud.

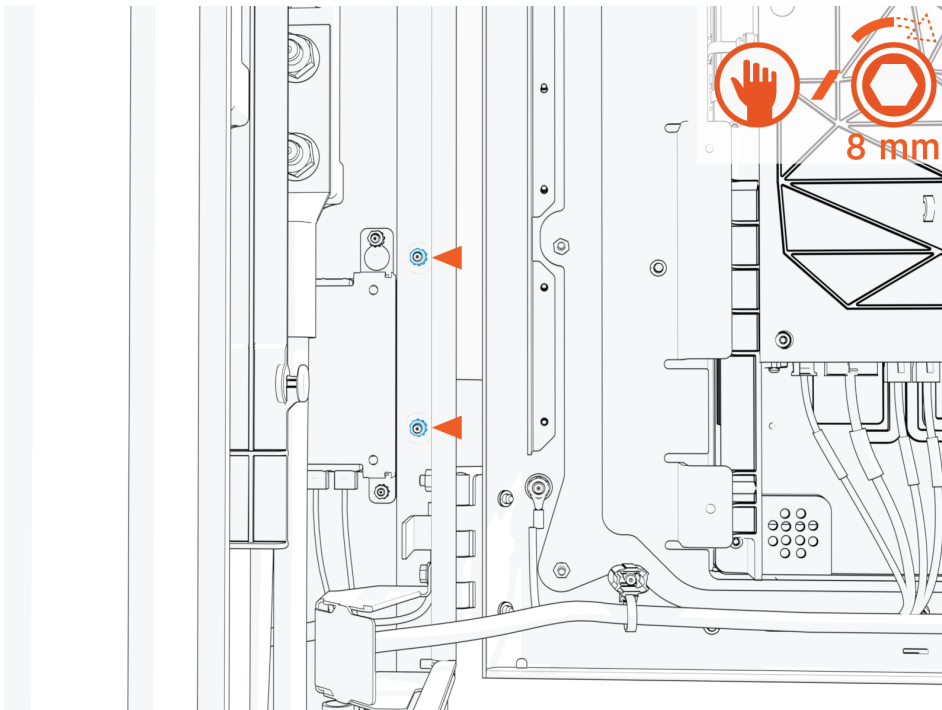

4. Mount the Ethernet to USB module onto the studs. Slide the module down to seat the notched tabs onto the studs.

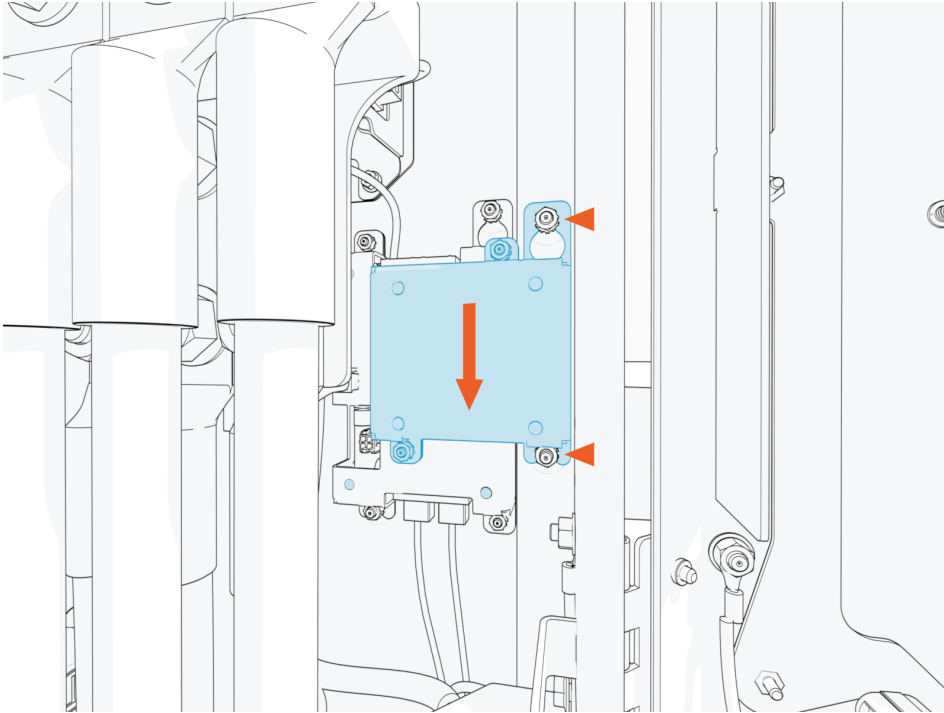

5. Torque nuts (x2) to **4.5 Nm (40 in-lb)**.



6. Plug the USB-B end of the USB cable into the module.

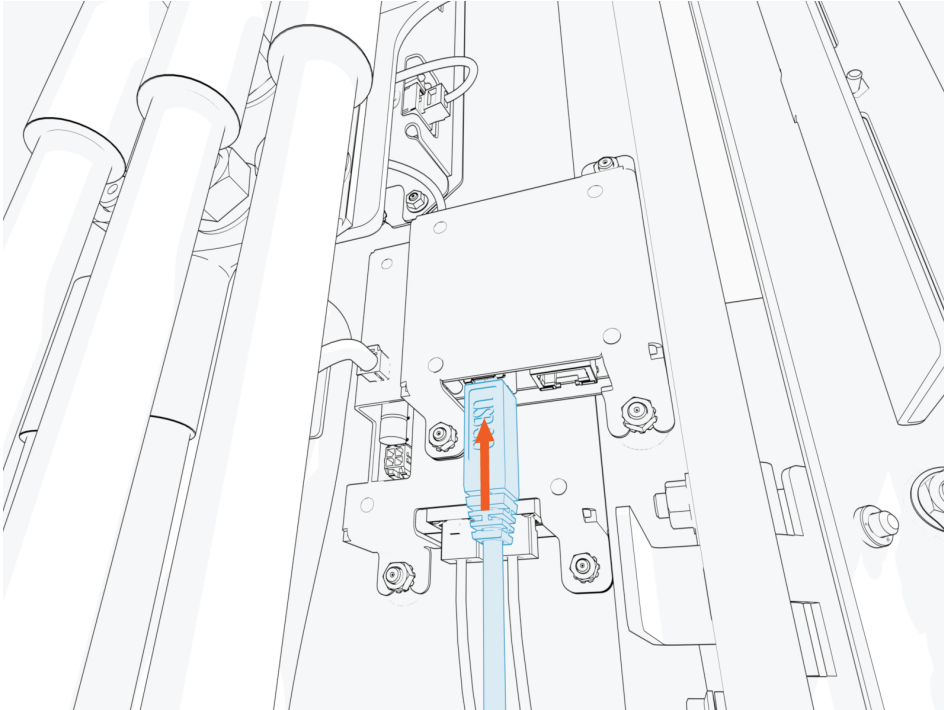

7. Route the cable through the door cable guide and along the main cable harness to the Control and Communication Module (CCOM) located on the Power Link 2000 door.

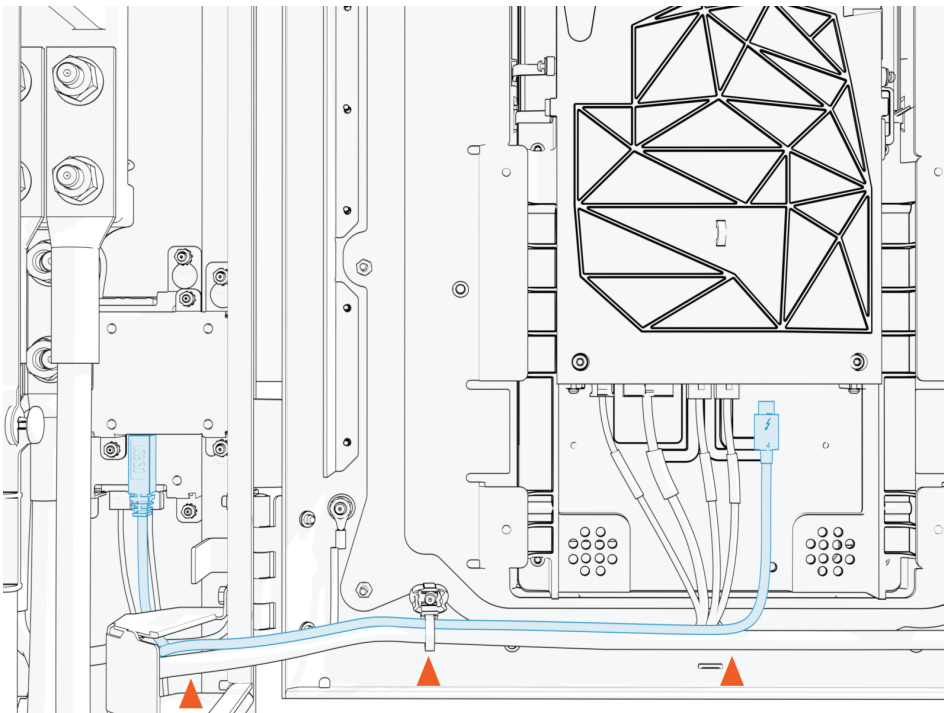

8. Connect the cable to the CCOM.

- Connection to 8-inch CCOM

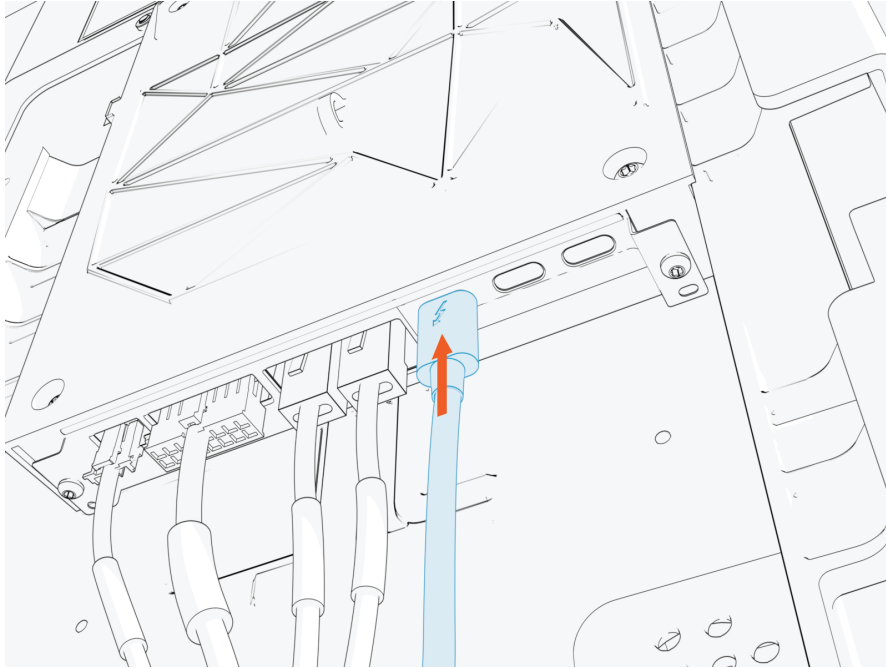

- Connection to 15-inch CCOM

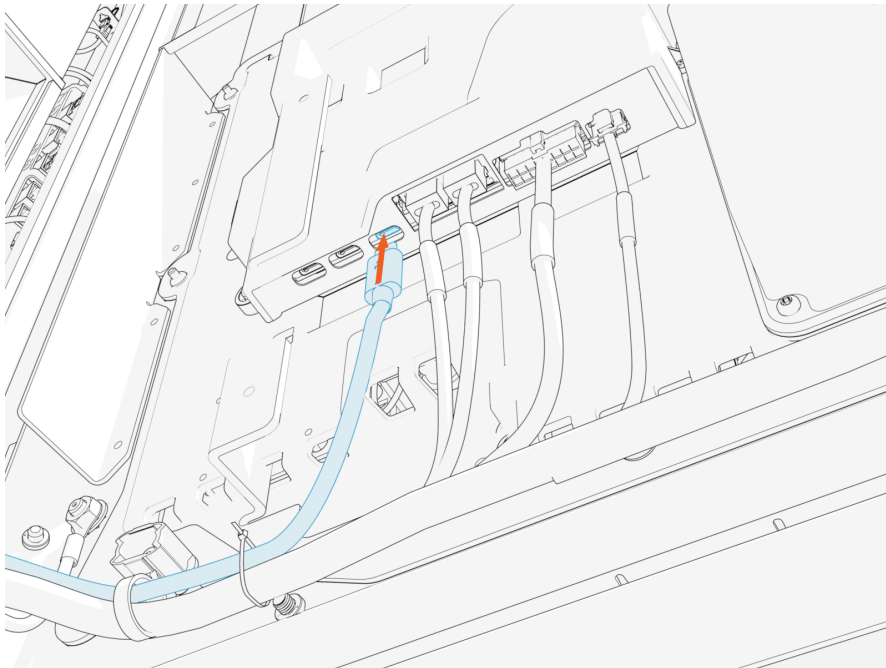

9. Zip tie the USB cable to the main cable harness.

IMPORTANT:



- Ensure the door can open and close without pinching or pulling of any cables.
- Ensure the USB cable does not touch the DC power path wires when the door is closed.

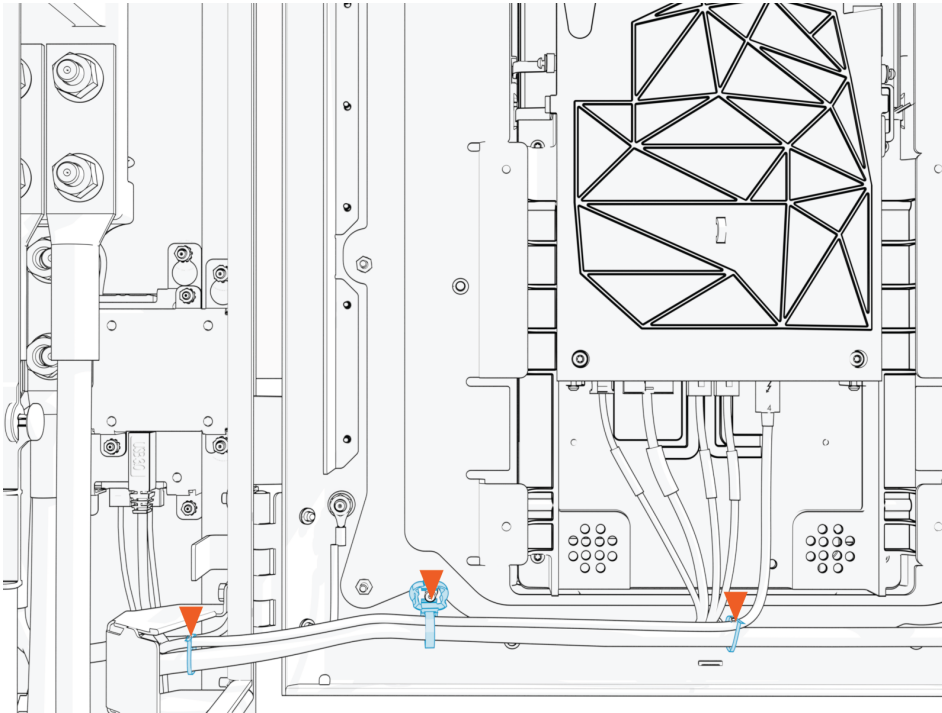

10. Pull the hardwire Ethernet cable and cut to length for landing at the Ethernet to USB module. Allow for a service loop.

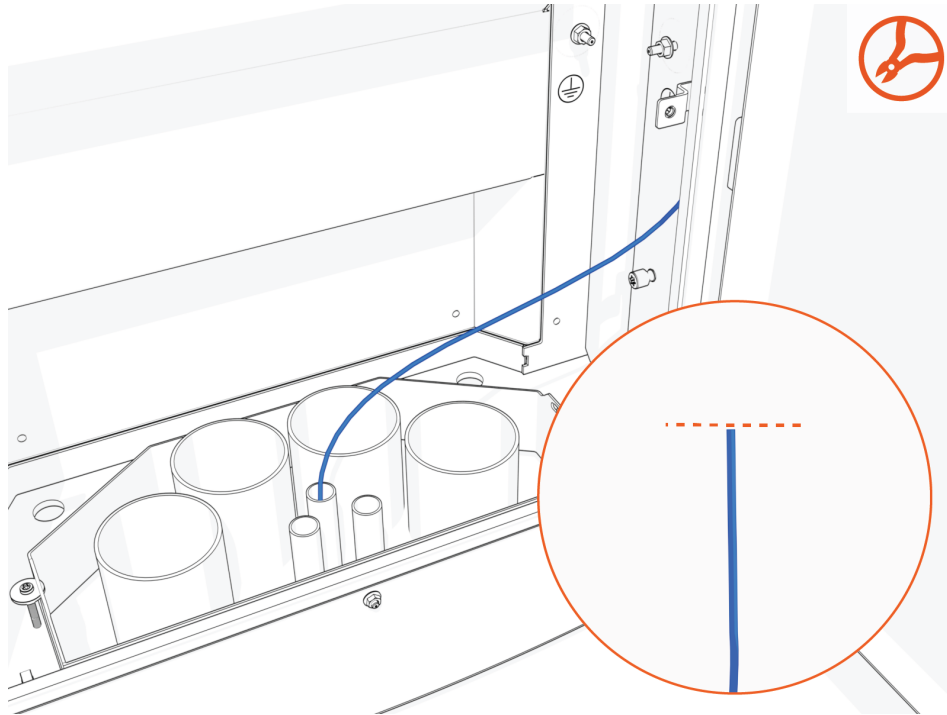

11. Field crimp an RJ45 connector onto the Ethernet cable. Use straight-through T568B pattern.



IMPORTANT: Do not ground the shield at this end of the Ethernet cable. Ground the shield at the end of the Ethernet cable that connects to the network server.

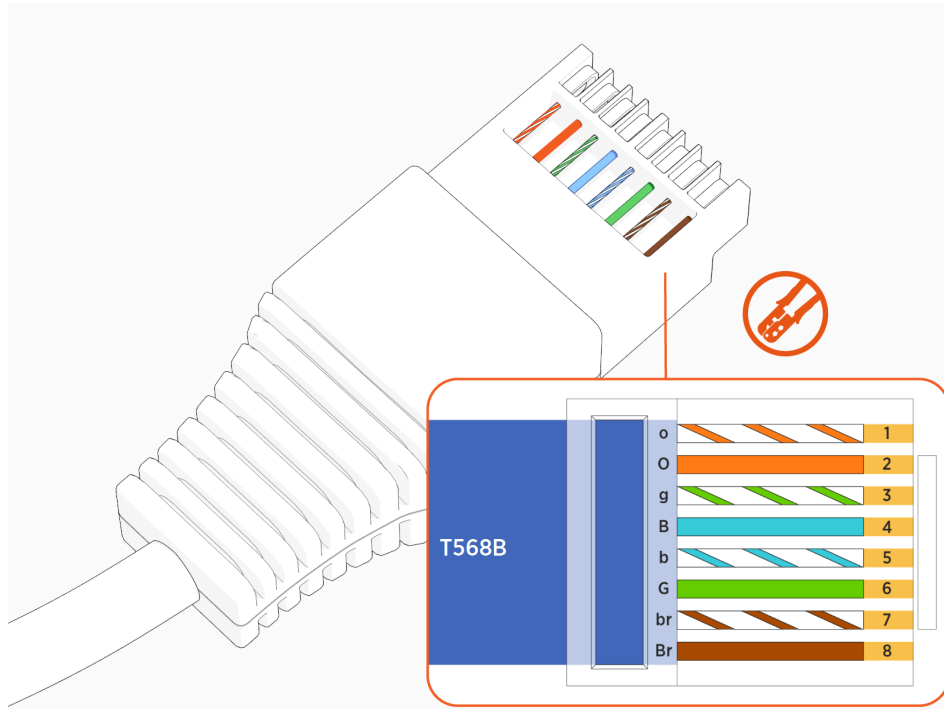

12. Test the Ethernet cable for functionality.



IMPORTANT: If using a Paige OSP Shielded GameChanger cable for a wire run length greater than 100 m (328 ft), follow the test procedure specified by Paige. See [Paige GameChanger Resources](#).

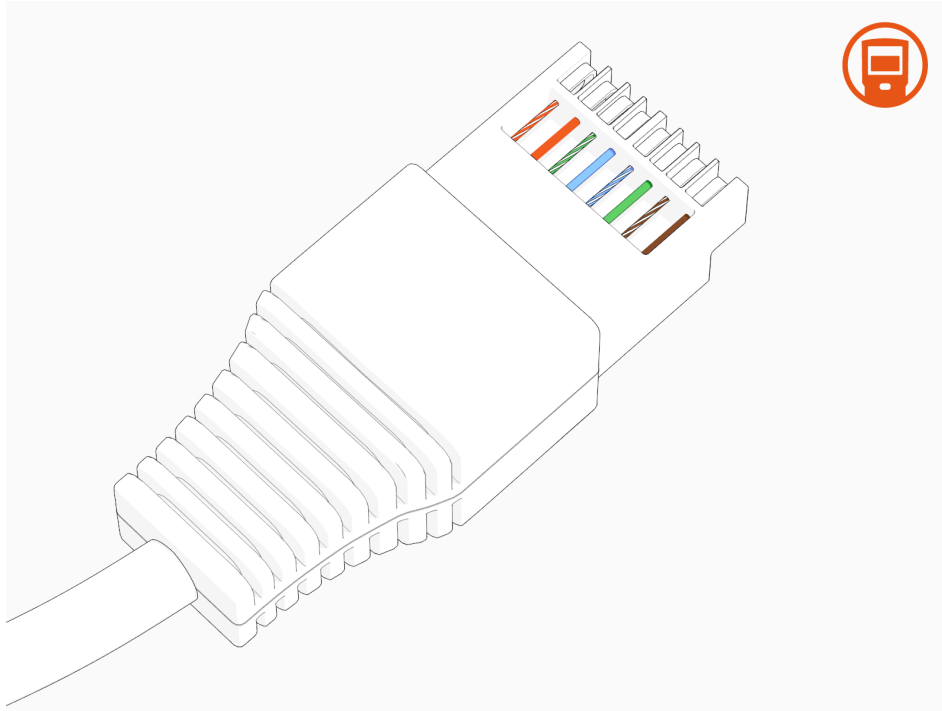

13. Route the Ethernet cable through wireway clamps and connect it to the Ethernet to USB module.

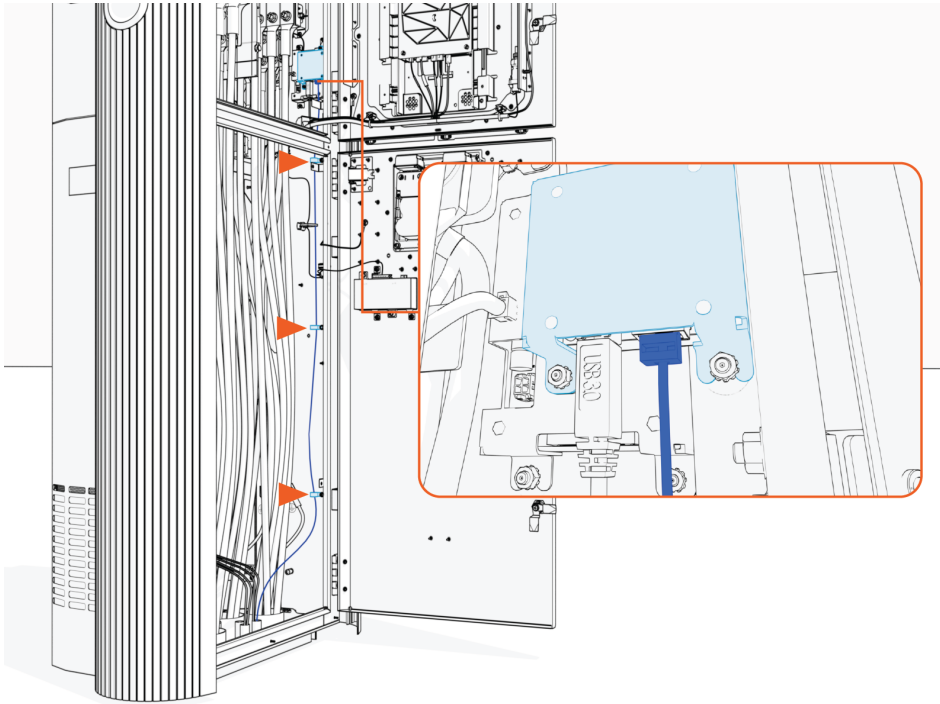

14. Route and connect the other end of the Ethernet cable to the network server.

Install Card Reader Kit

If the site plan indicates the Power Link 2000 must be configured with a card reader, follow procedures below to install the Card Reader Kit.

1. Unpack the Card Reader Kit. Confirm all parts listed below are present.



NOTE: For any missing component, contact chargepoint.com/support.

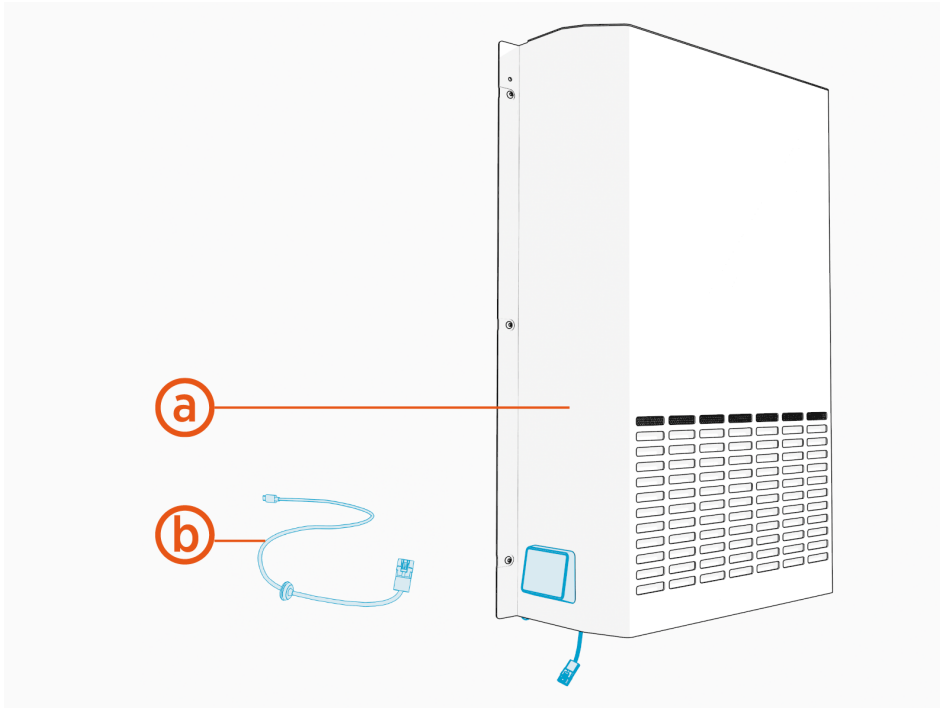

- (a) Replacement rear upper cover with pre-installed card reader
- (b) Long cable for connecting the card reader to Power Link 2000

2. Loosen screws (x6) to remove the existing rear upper cover of the Power Link 2000.



3. Connect the USB-C end of the long cable to the Control and Communication Module (CCOM).

- Connection to 8-inch CCOM

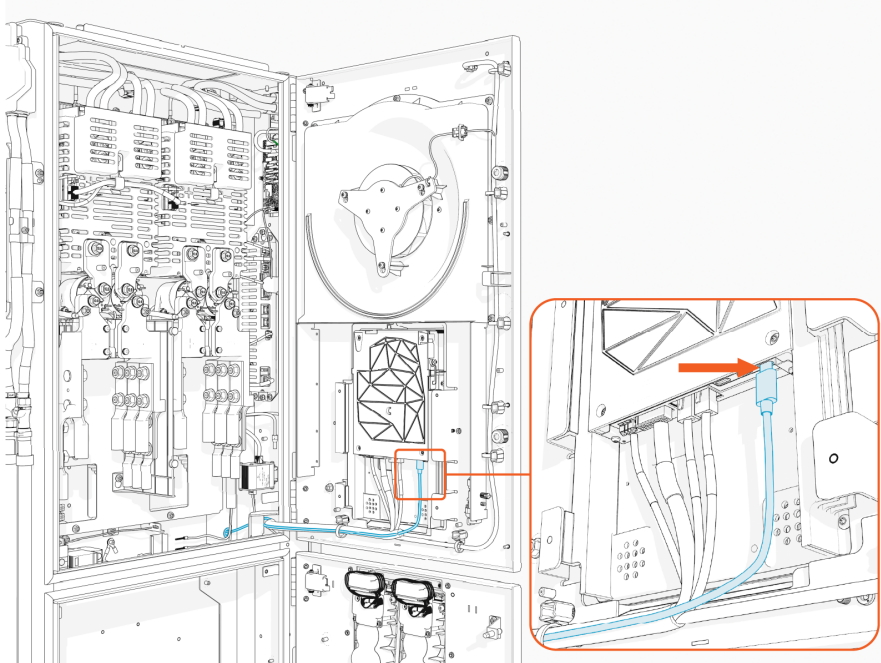

- Connection to 15-inch CCOM

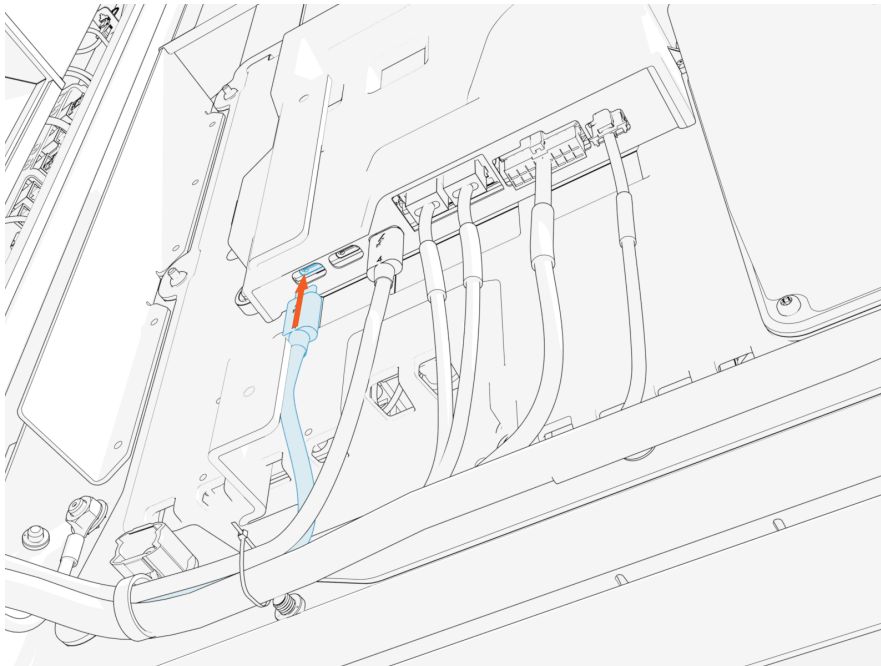

4. Route the long cable's other connector to rear side through a hole at the back of the Power Link 2000 and insert the grommet into the hole.



IMPORTANT: Make sure to route and tie the long cable using cable ties to the main cable harness.

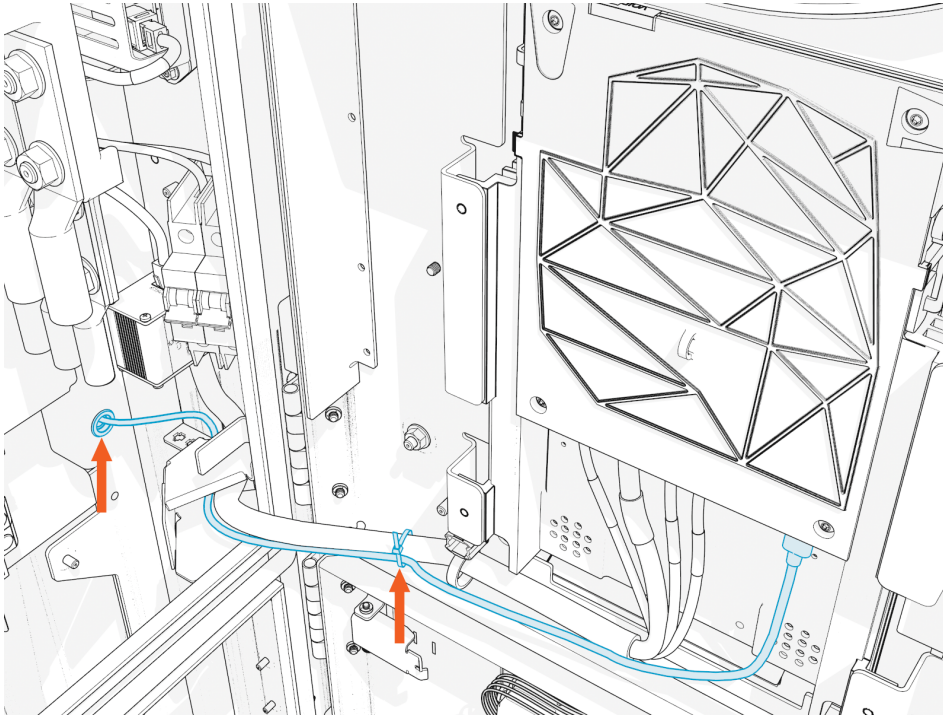

5. Bring the replacement upper rear cover (with card reader pre-installed) close to the rear of the Power Link 2000. Connect the card reader cable to the long cable.

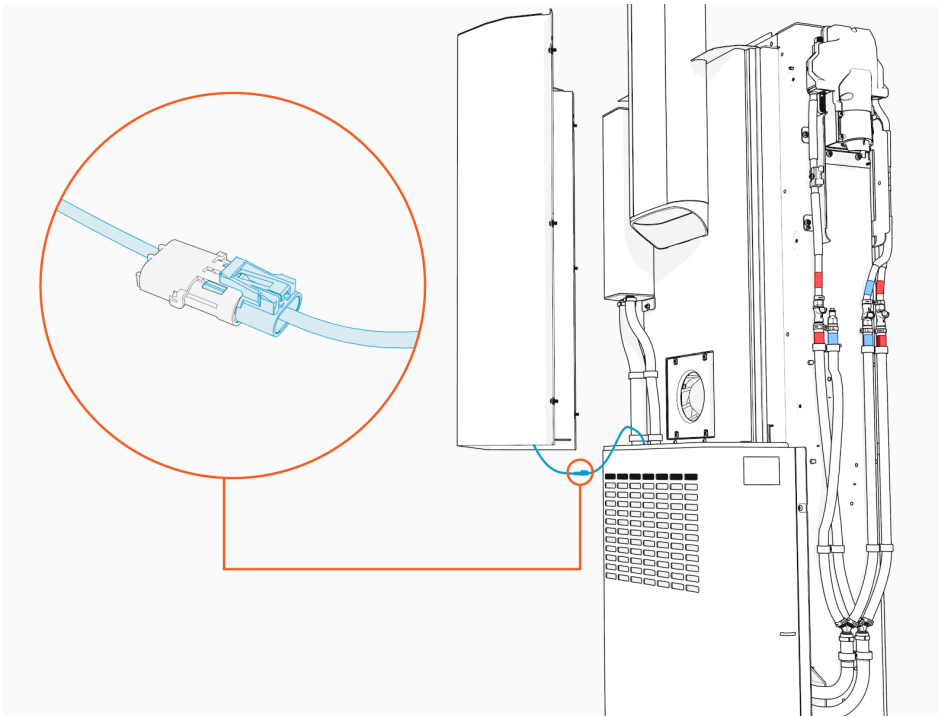

6. Align and seat the replacement rear cover onto the alignment pins (x2) on the frame of the Power Link 2000.

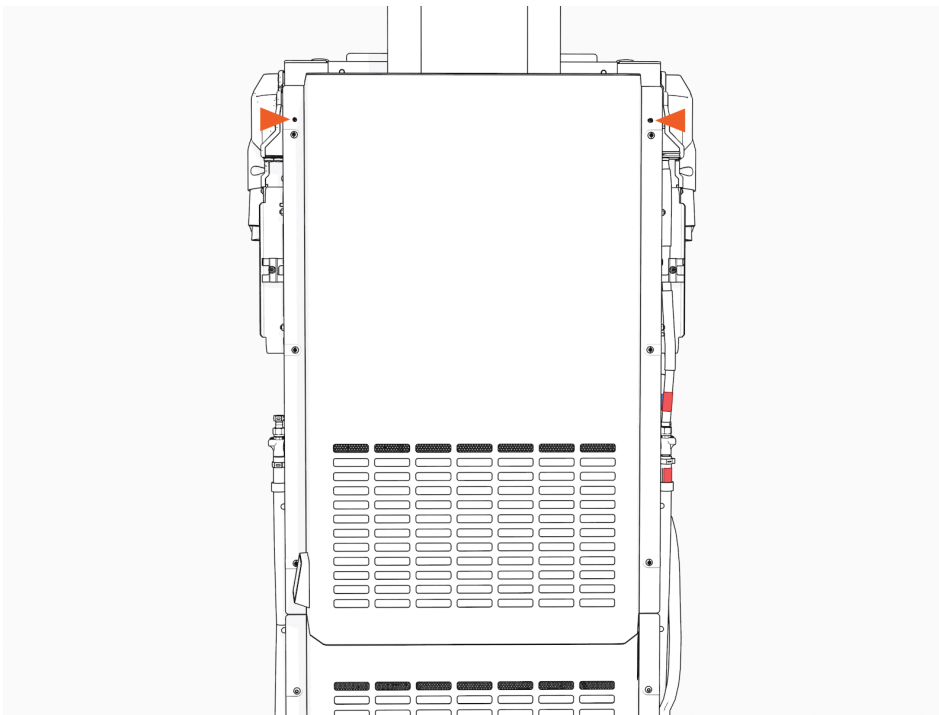

7. Torque the screws to **4.5 Nm (40 in-lb)**.

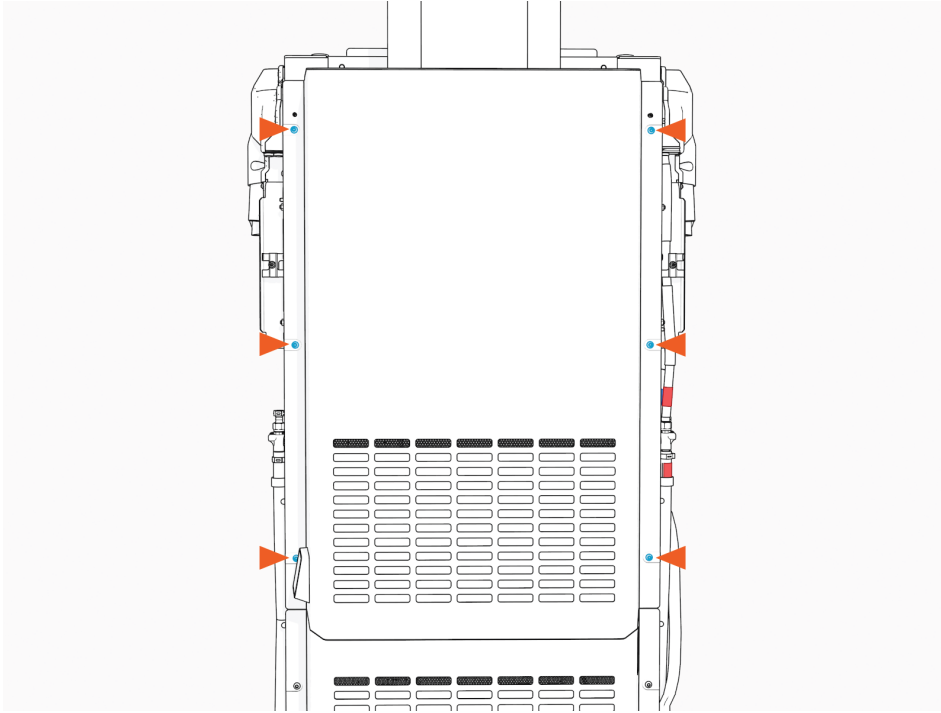

8. Check the removed cover for a label with serial number (SN). Request a replacement label for the new cover. Install the new label.



IMPORTANT: To request a new label with SN, contact chargepoint.com/support.

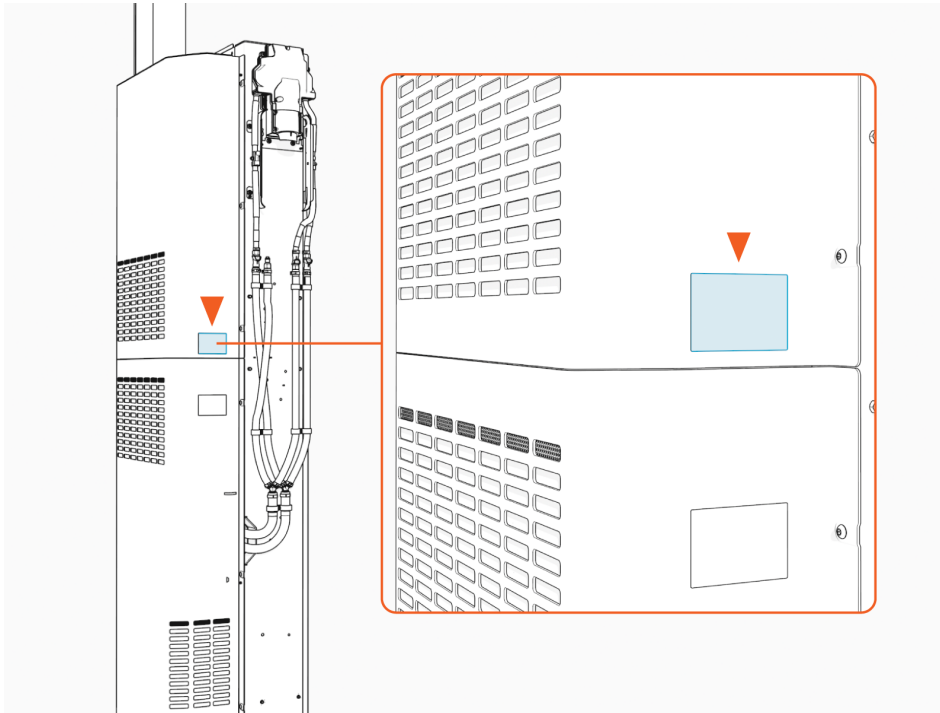

Install Sequential Charging Kit

If the site plan indicates the Power Link 2000 must be configured for sequential charging, follow procedures below to install the Sequential Charging Kit.

1. Unpack the Sequential Charging Kit. Confirm all parts listed below are present.



NOTE: For any missing component, contact chargepoint.com/support.

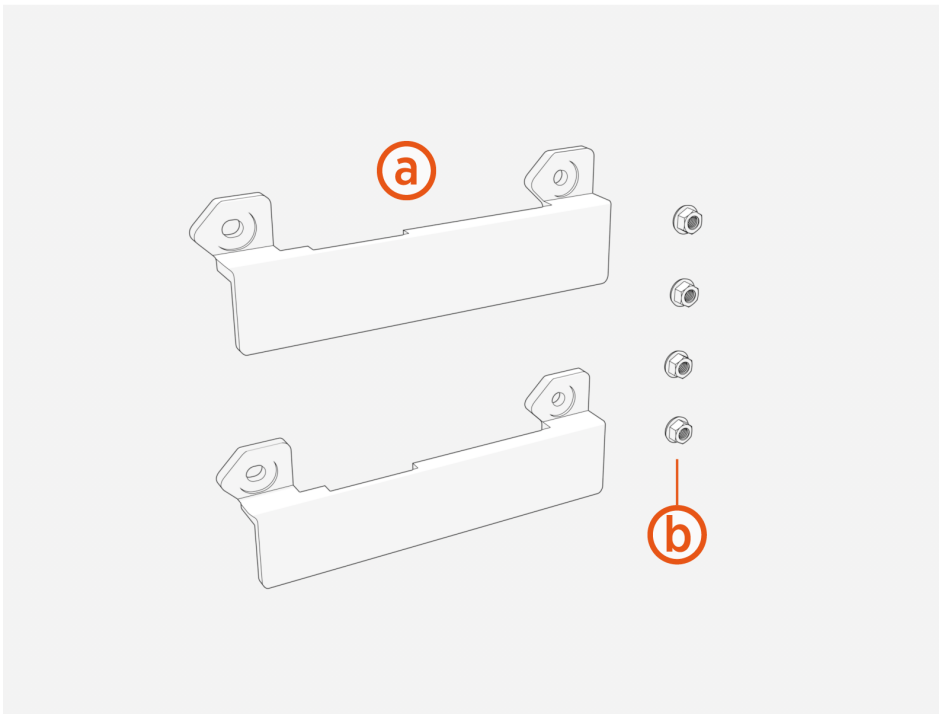

(a) Bus bar bridges (x2)

(b) M8 captive washer nuts (x4)

2. Install the bus bar bridges (x2).

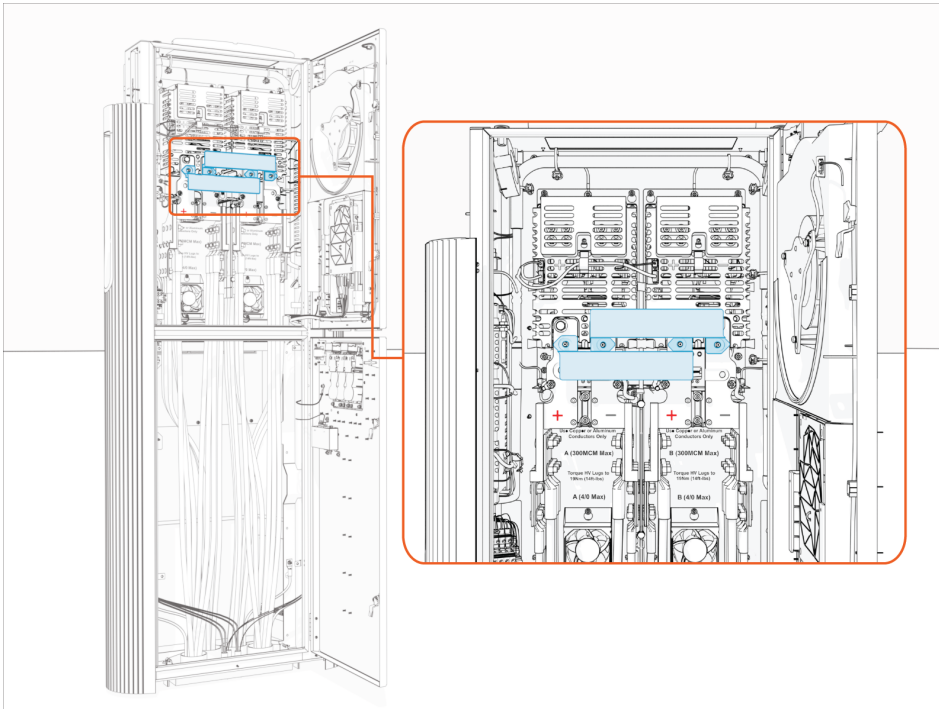

3. Fasten with captive washer nuts (x4). Torque to 12.2 Nm (108 in-lb).

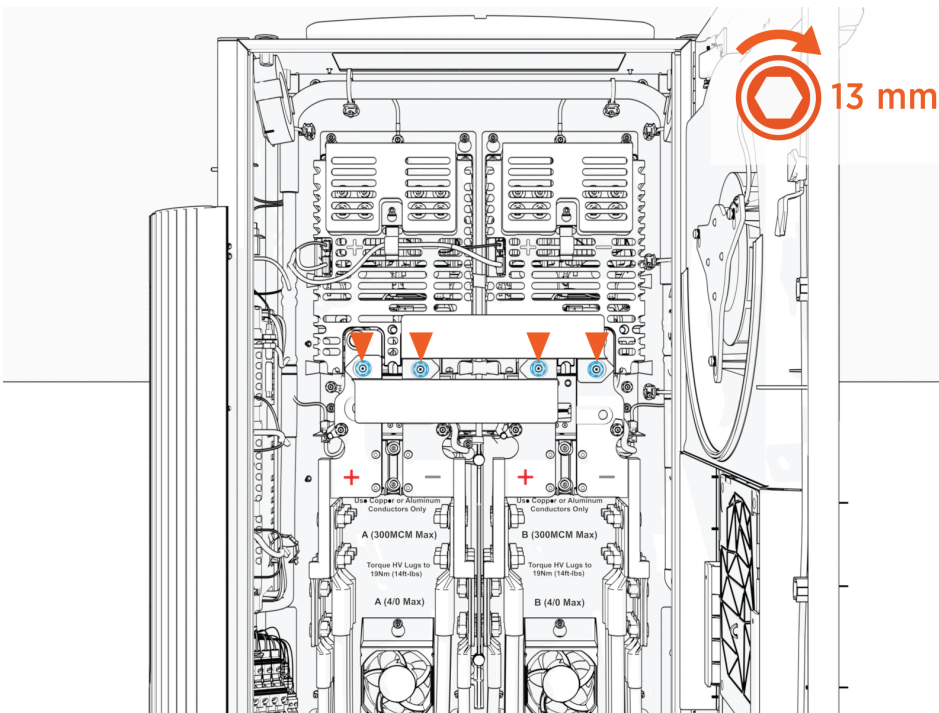

Install Soft Shutdown Switch Wiring

If the site plan indicates the Power Link 2000 must be configured with a soft shutdown switch, follow procedures below to install the soft shutdown switch wires.

1. Pull the soft shutdown switch wiring through the conduit.

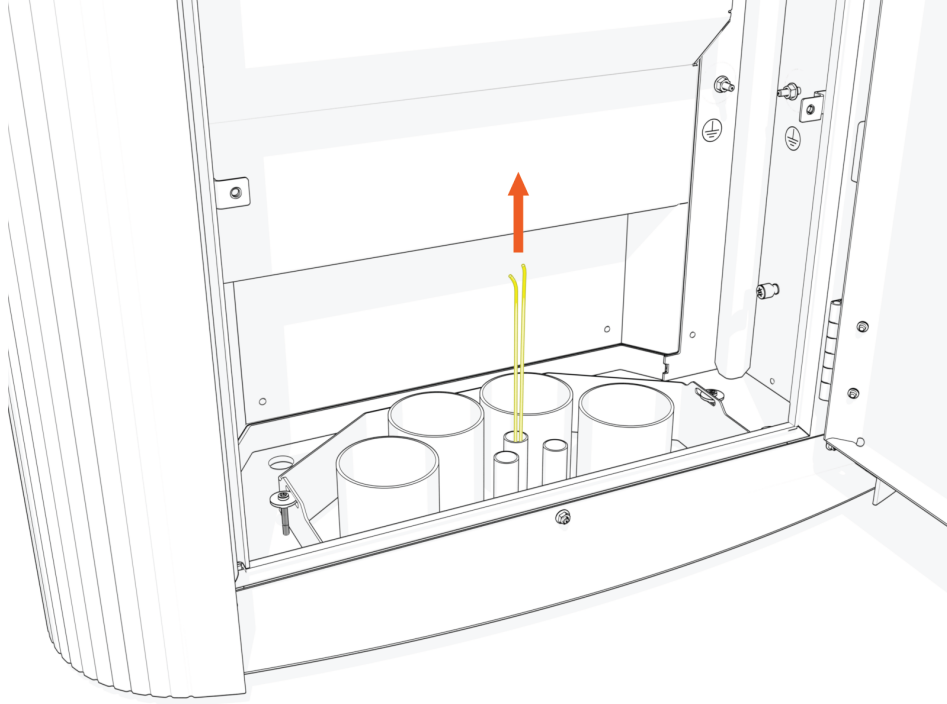

2. Loosen set screws (x2) at the soft shutdown terminal.

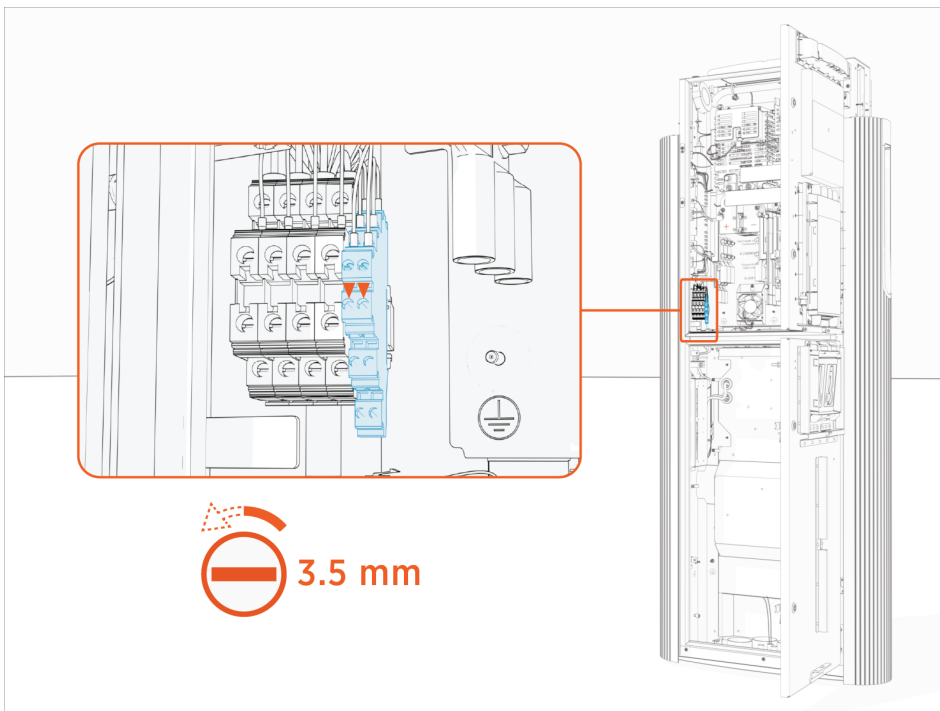

3. Twist the soft shutdown switch wires together, using a minimum of five twists per foot.

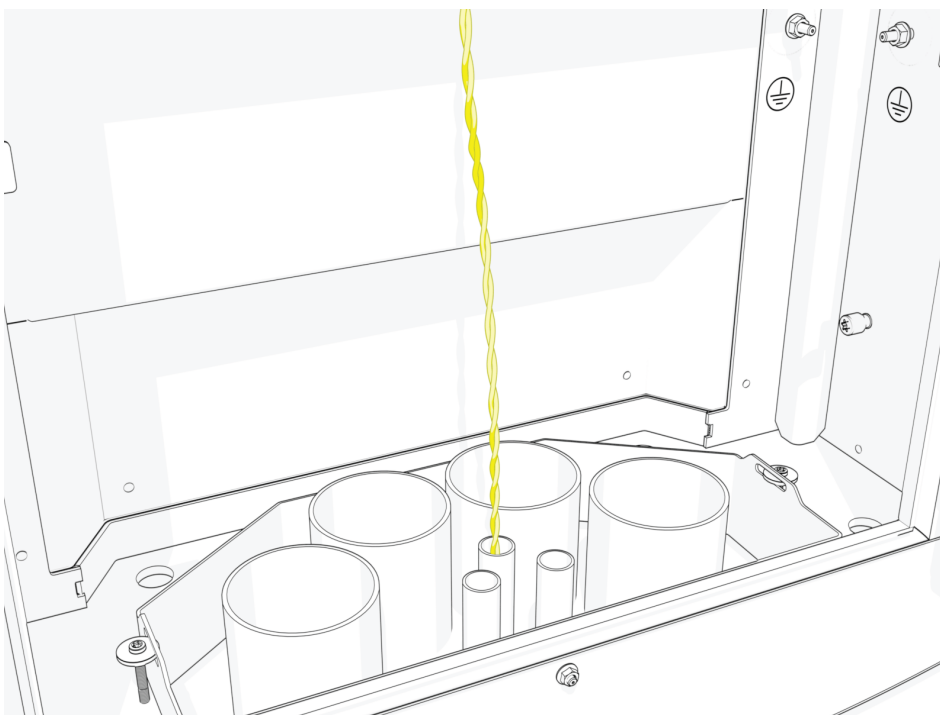

4. Route the twisted wires through the wireway clamps (if necessary, use cable ties) towards the soft shutdown terminal. Cut the wires to length for landing at the terminal.

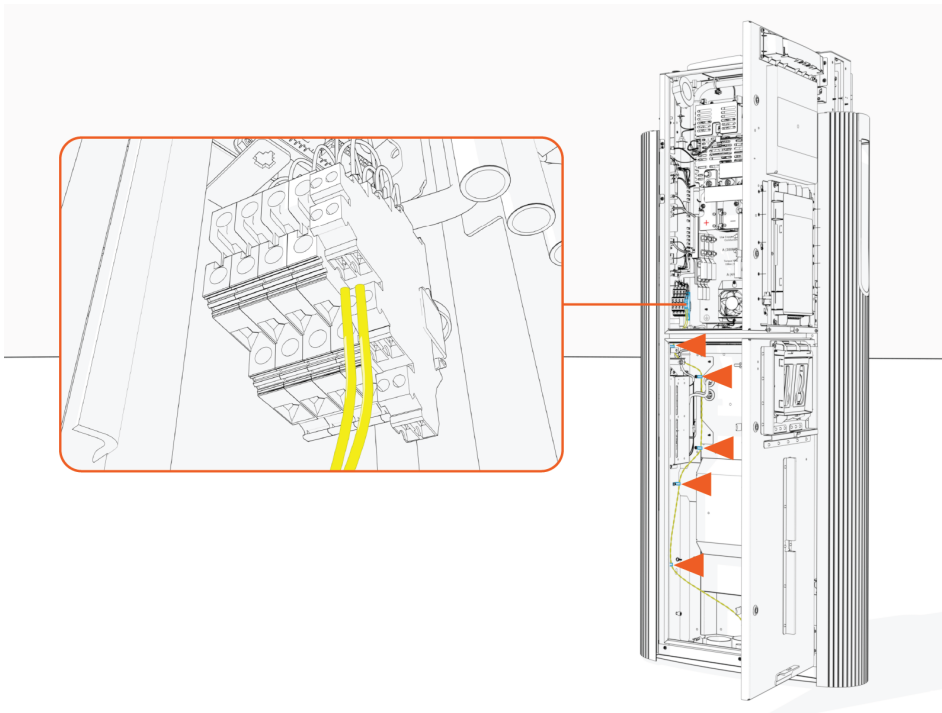

5. Strip the wire ends. If using wire ferrules, install the ferrules after stripping the conductors.

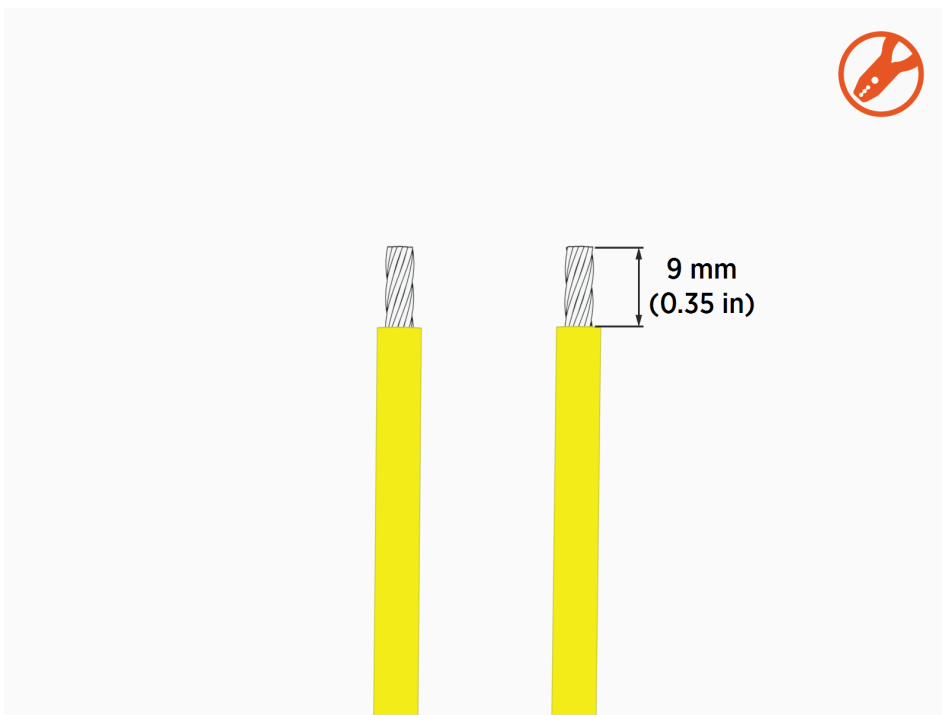

6. Insert the wires into the soft shutdown terminal. Torque set screws (x2) to **0.6 Nm (5.3 in-lb)**.

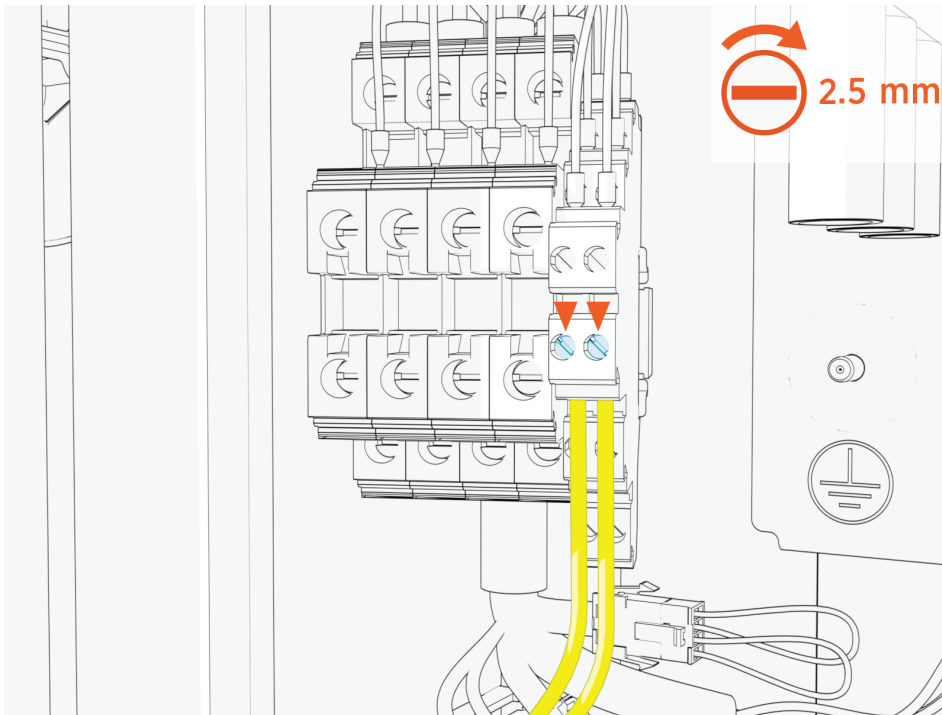

Install Safety Hub Jumper Wire in Upstream Power Cabinet

If the Power Link 2000 is powered by an Express Solo or Power Block 2000, you must install the Safety Hub jumper wire in the upstream power cabinet. The jumper wire ships with the Power Link 2000, but its installation is performed inside the upstream cabinet. Refer to the installation guide for the Express Solo or Power Block 2000 for jumper wire installation procedures.

Install Charging Cables 5



IMPORTANT: Skip this entire chapter if the liquid-cooled cables come preinstalled (see [Power Link 2000 with LCC](#)).

The Power Link 2000 may be configured with one or two liquid-cooled cables (LCC) or non-liquid-cooled cables (non-LCC). The Power Link 2000 with LCC comes with a liquid cooling system attached to the back of the Power Link 2000 (see [Charging Cable Type and Quantity](#) for more information). To install charging cables, follow the instructions below:

LCC

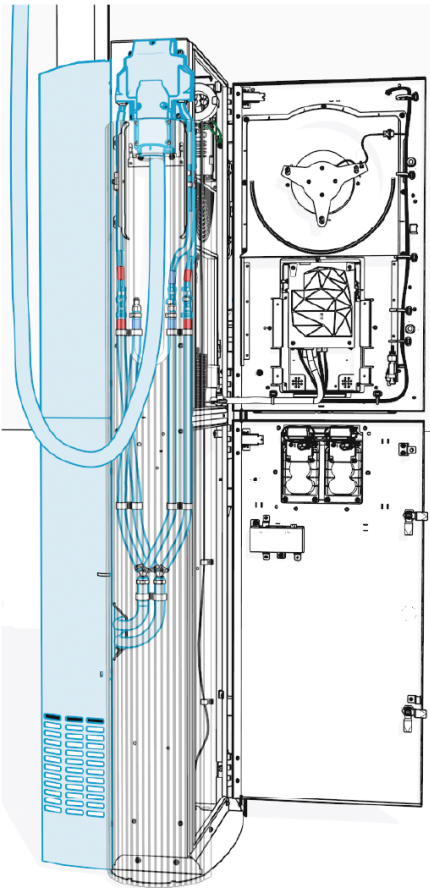

Non-LCC

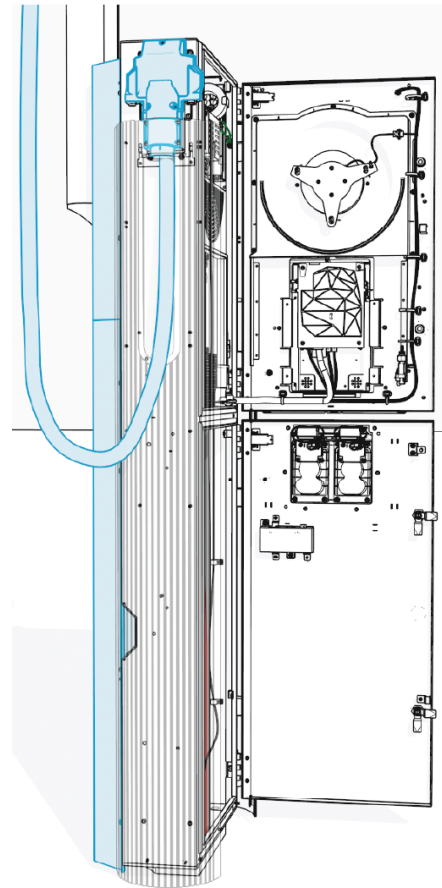

Charging Cable Package

Check the package for the following components:



NOTE: For any missing component, contact ChargePoint support at chargepoint.com/support.

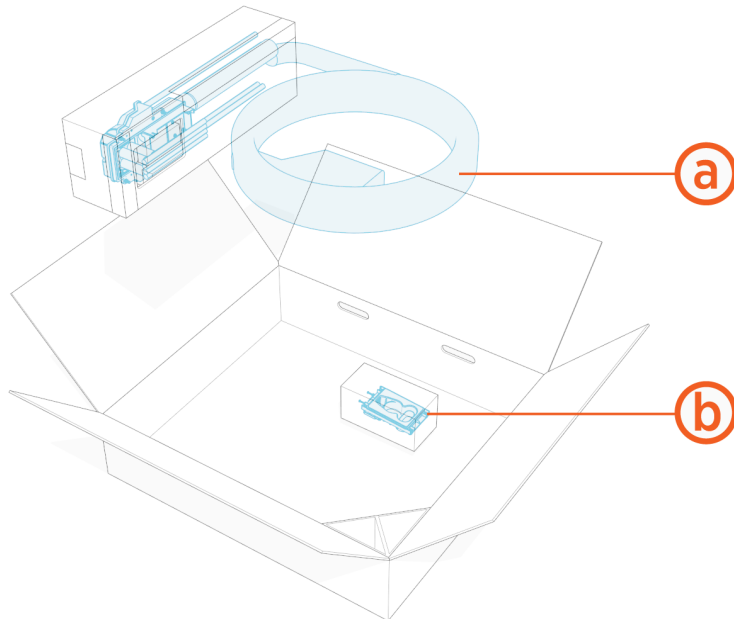

- (a) Charging cable assembly with connector and tetherball
- (b) Holster for placing the cable connector



NOTE: Standard length (5.8 m or 19 ft) charging cables come with a tetherball preinstalled onto the cable. For non-LCC medium length (7.6 m or 25 ft) charging cables, a tetherball is not preinstalled onto the cable. It must be installed after installing the charging cable or while installing the CMK.

Remove Cable Cap

Pull the cable cap up to remove and keep it aside to reinstall it later.

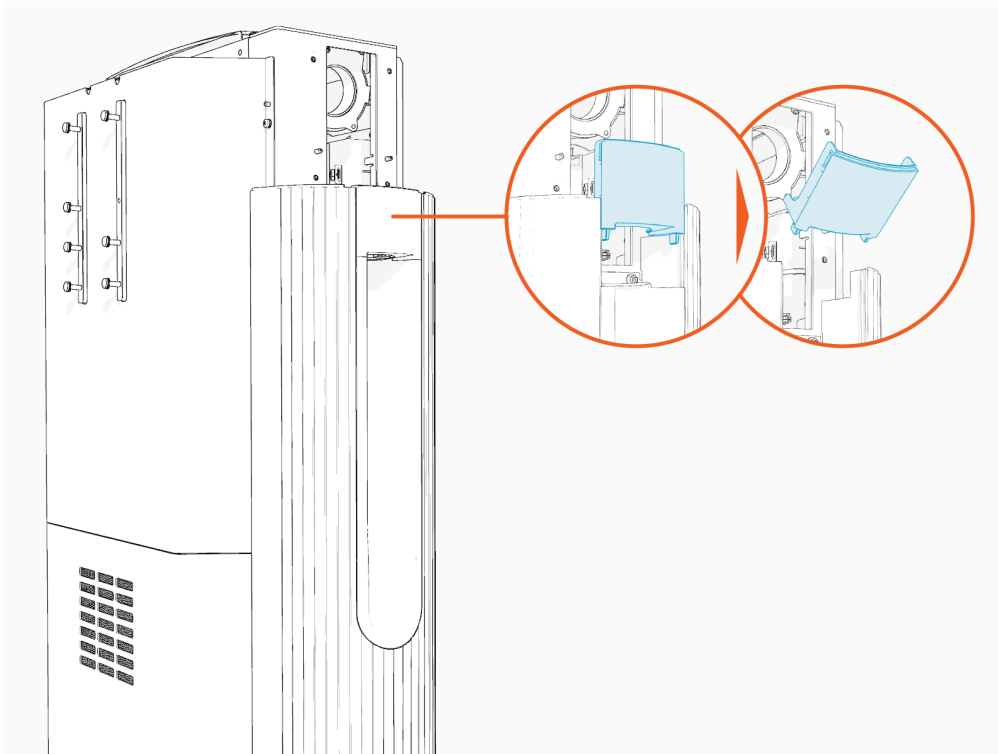

Remove High-Power DC Lug Landing Bus Bar Safety Cover

To remove high-power DC lug landing bus bar safety cover, complete the following steps:

1. Loosen the screw (x1 per safety cover).

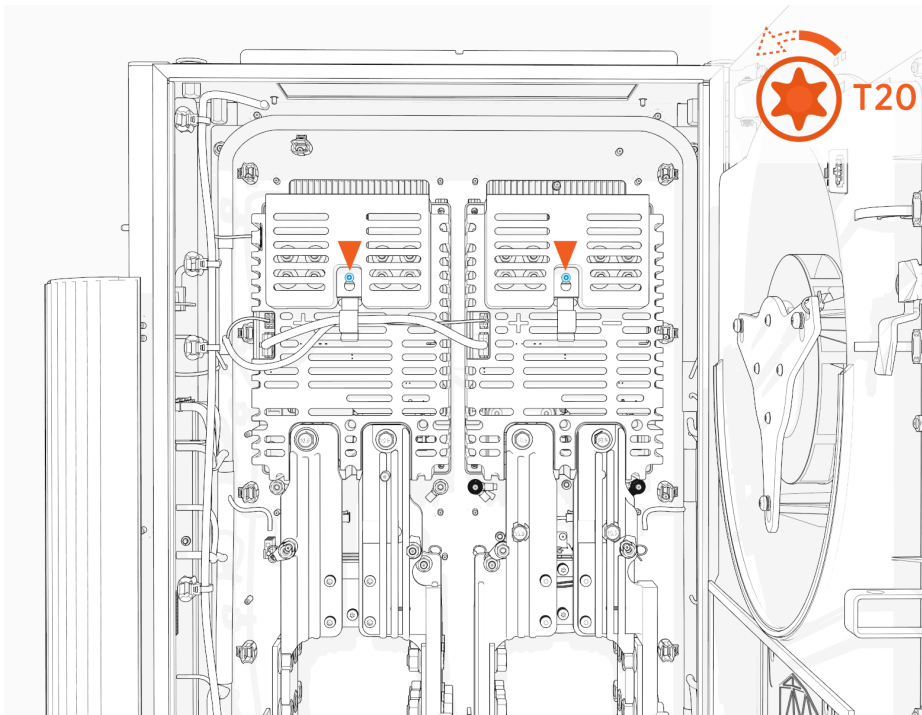

2. Slide the safety cover up to remove it from the screw.

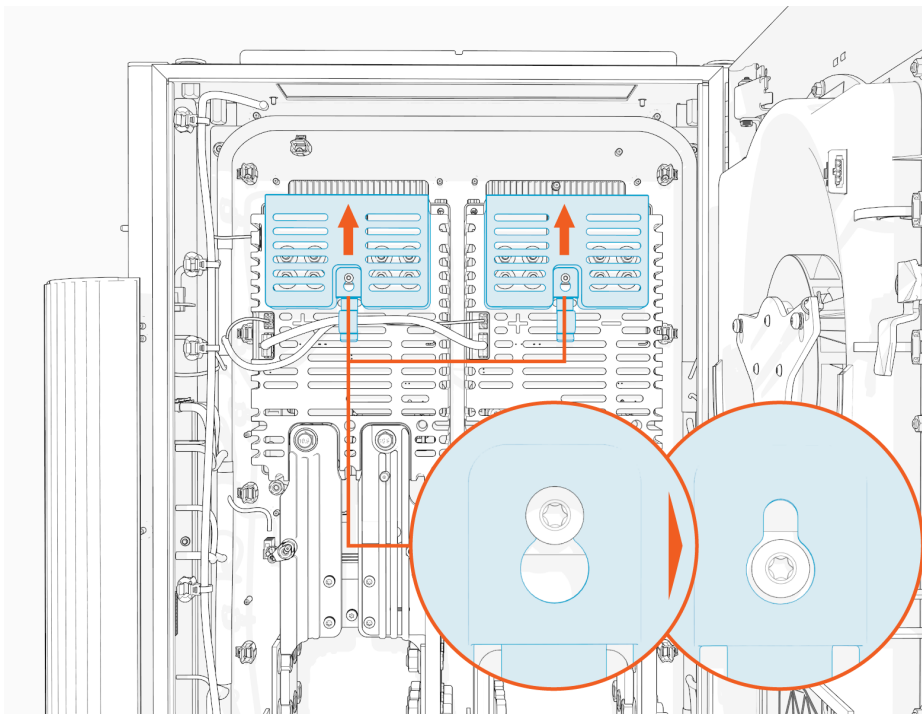

Install Cable Assembly

Follow instructions below to install each charging cable assembly.

1. Route the red (+) and black (-) high-power DC wires through the Ferrite ring. Route other wires, such as ground (green) and Ethernet, outside of the Ferrite ring.



IMPORTANT: While routing the left side cable through the Ferrite ring, make sure that the red (+) wires are at the front side and black (-) wires are at the rear side to easily maneuver and land them onto their respective poles. Conversely, while routing the right side cable, make sure that the black (-) wires are at front side and red (+) wires are at the rear side.

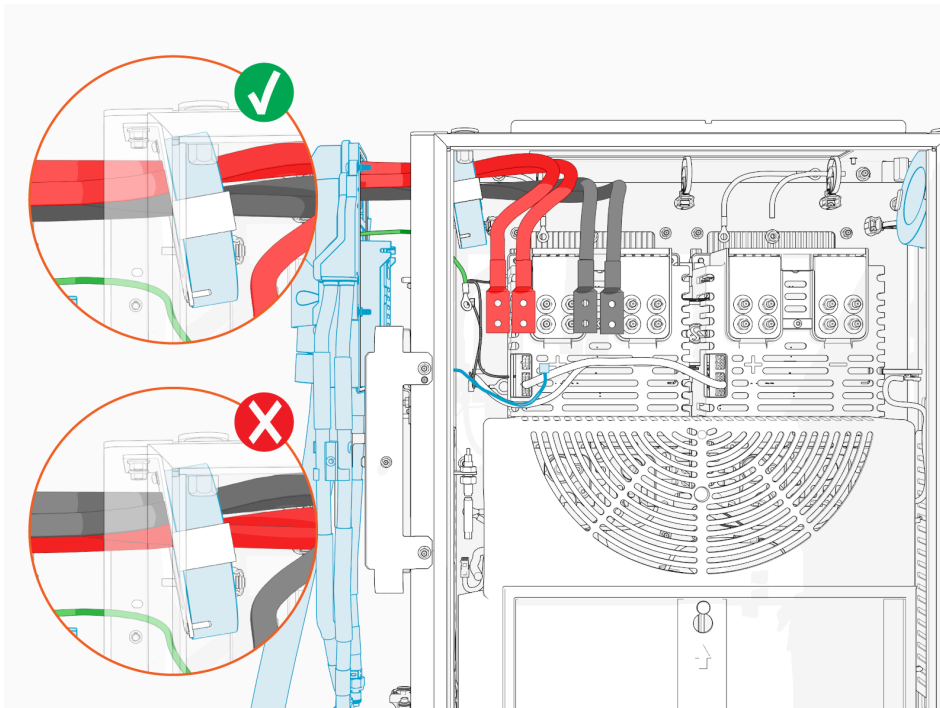

2. Install cable assembly onto the alignment pins (x2).



CAUTION: Ensure the small cables do not get pinched between the cable assembly and the Power Link 2000 frame.

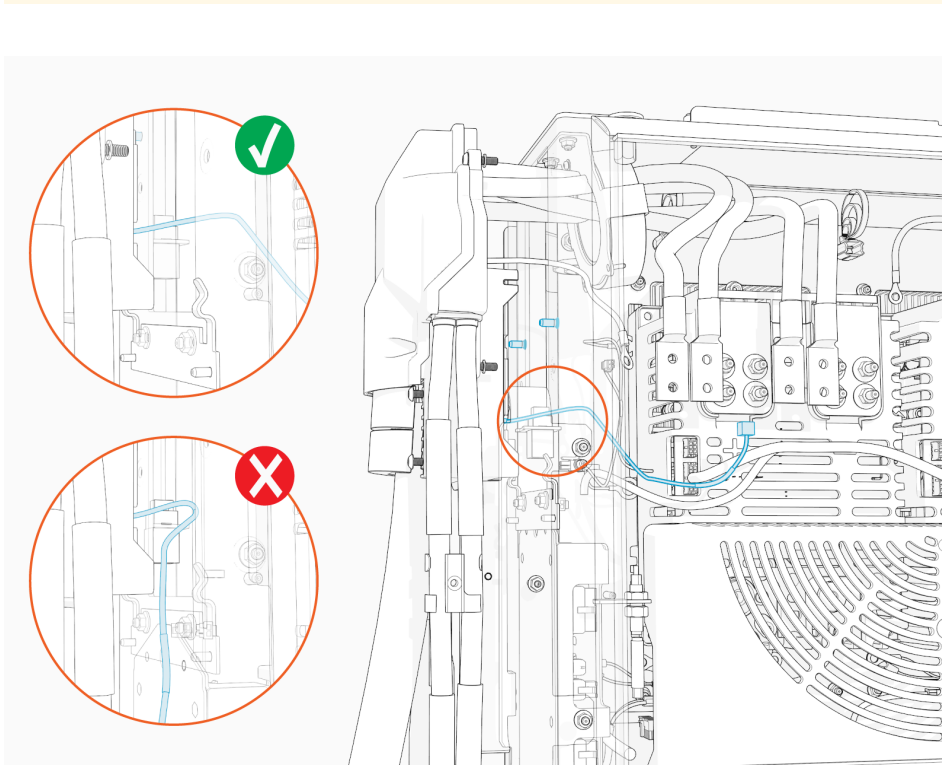

3. Torque the screws (x4) to 4.5 Nm (40 in-lb).

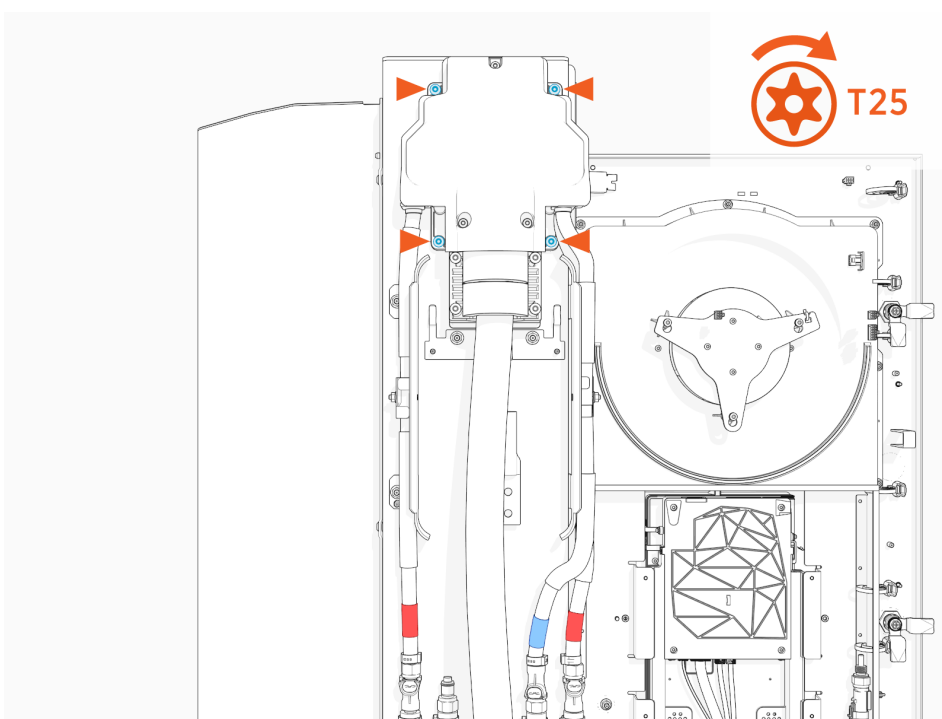

Connect High-Power DC and Ground Wires

Complete the following steps to connect the charging cable high-power DC wires and ground wires.



NOTE: In the illustration below, the high-power DC conductors from the left charging cable land on the left Proton, and the high-power DC conductors from the right charging cable land on the right Proton.

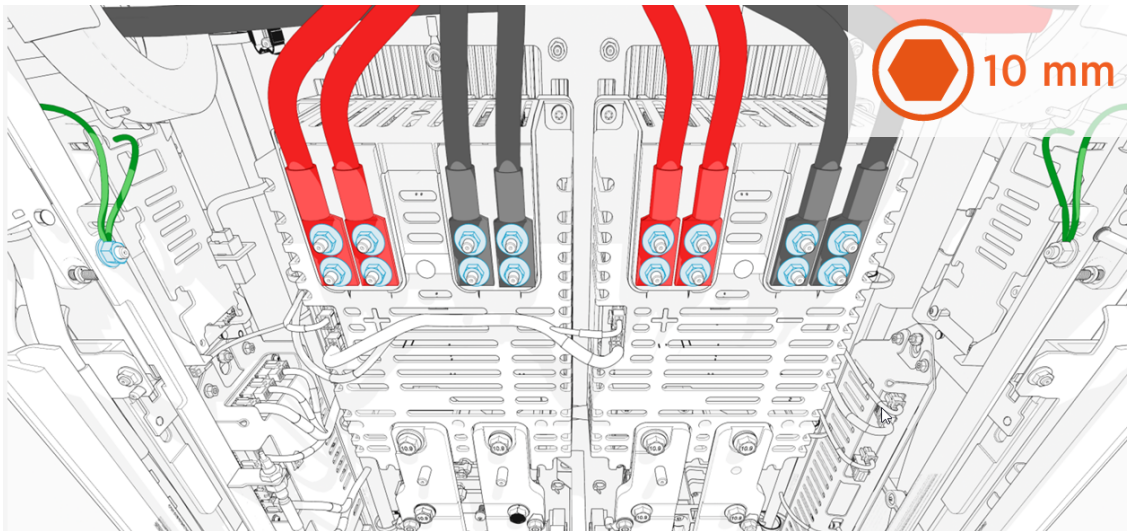

1. Remove the lug nuts (x4 per red and black high power DC wires; x1 per green ground wire).
2. Connect red high-power DC wire conductors to the positive (+) landings and black high-power DC conductors to the negative (-) landings.
3. Connect green ground wires (x2 per charging cable) to ground studs on the frame.
4. Torque all lug nuts to **5.6 Nm (50 in-lb)** and mark using a torque paint pen.

Connect 48 V DC and Ethernet Wires

Complete the following steps to connect the charging cable 48 V DC and Ethernet wires.

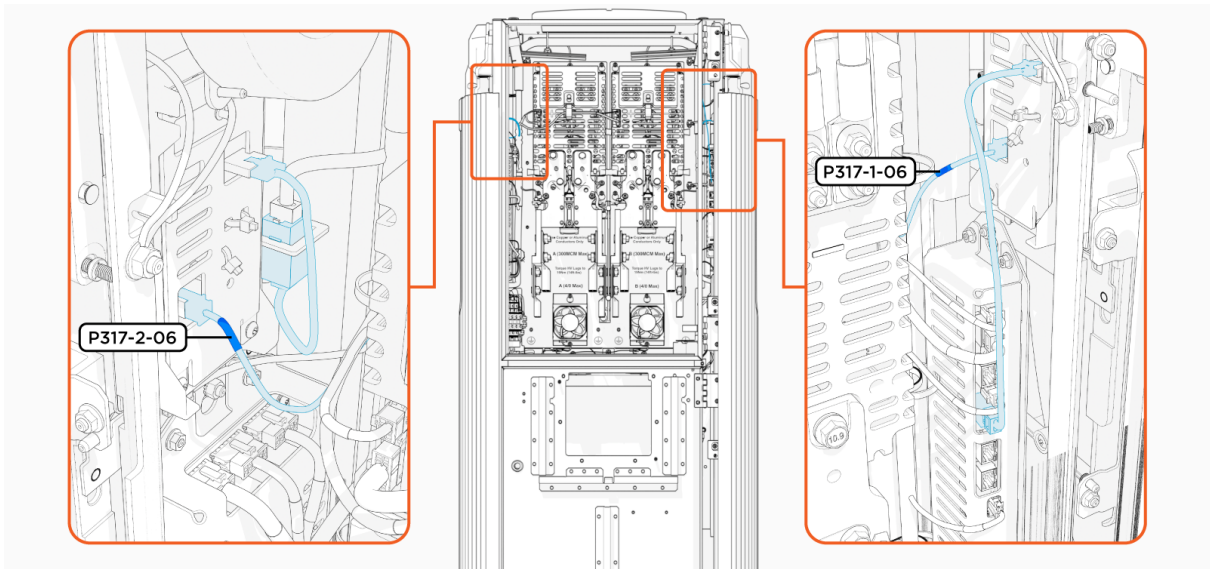

1. Plug in the 48 V DC wires (with labels P317-2-06 and P317-1-06) to four pin socket on the cable assembly.
2. Plug in the Ethernet cable from the charging cable assembly, as illustrated above.

Reinstall High-Power DC Lug Landing Bus Bar Safety Cover

To reinstall the high-power DC lug landing bus bar safety cover, complete the following steps:

1. Install the safety cover onto the screw (ensure that the screw is loose) and slide it down.

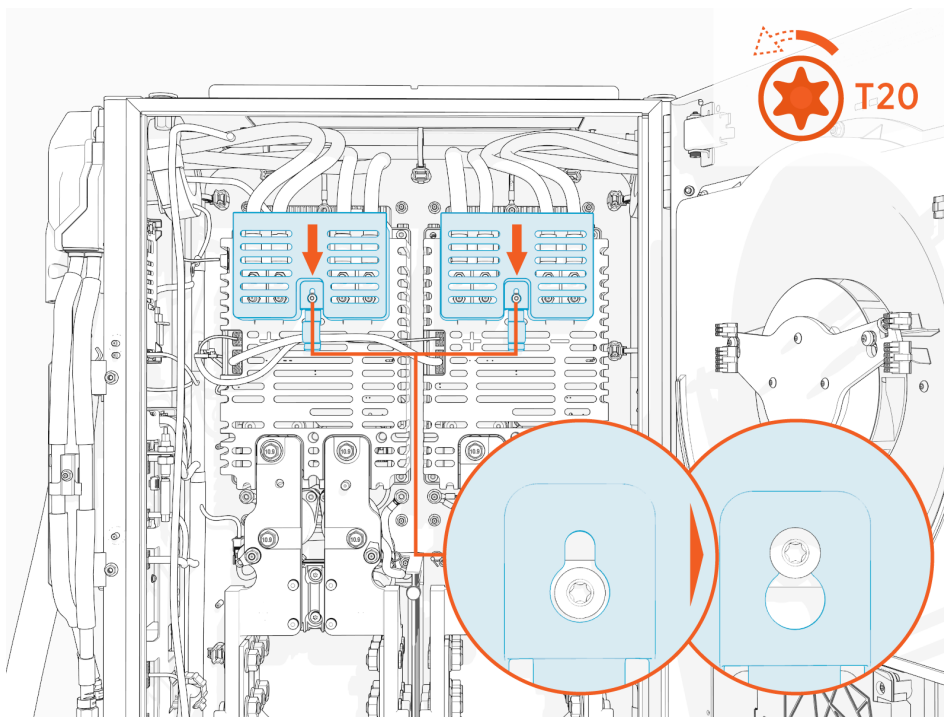

2. Torque the screw to **1.7 Nm (15 in-lb)**.

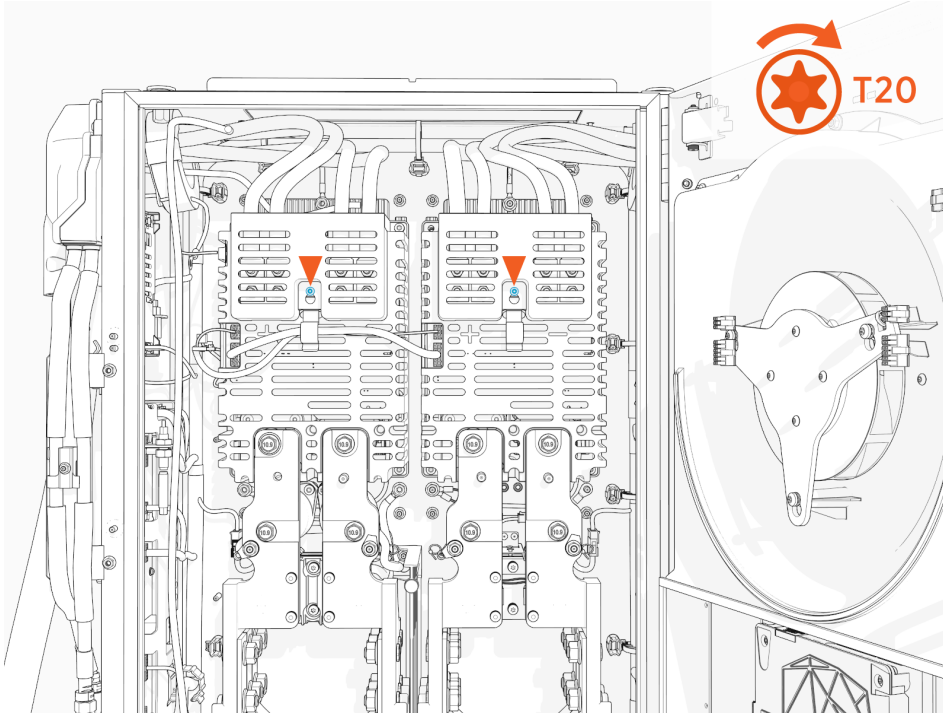

3. Tuck the internal low voltage supply wires under the wireway tab on the cover.

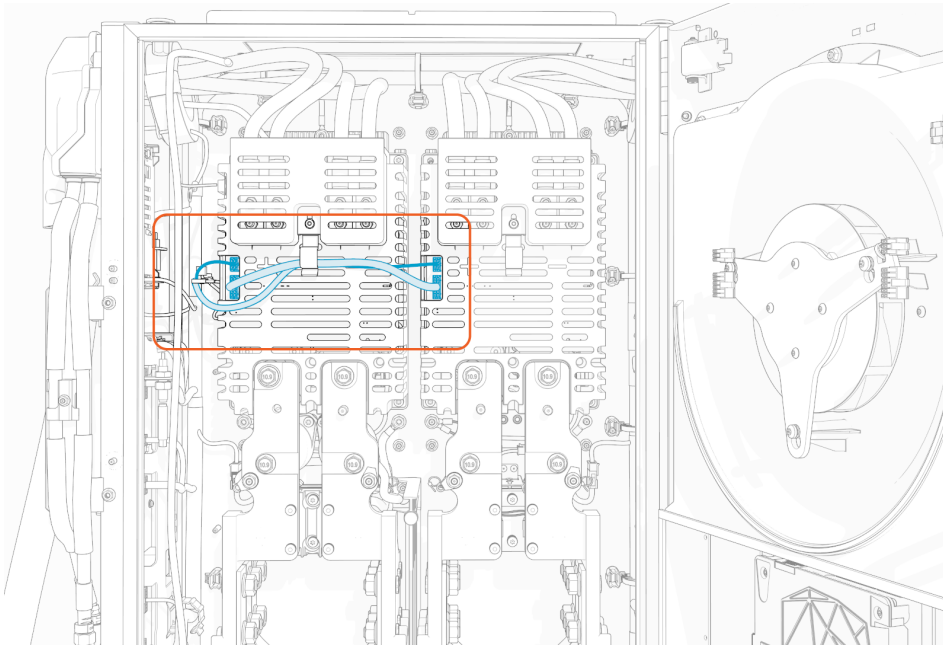

Install Holsters

Power Link 2000 can be configured with standard holsters or Omni Port. A newly shipped Power Link 2000 shall arrive in one of the following configurations:

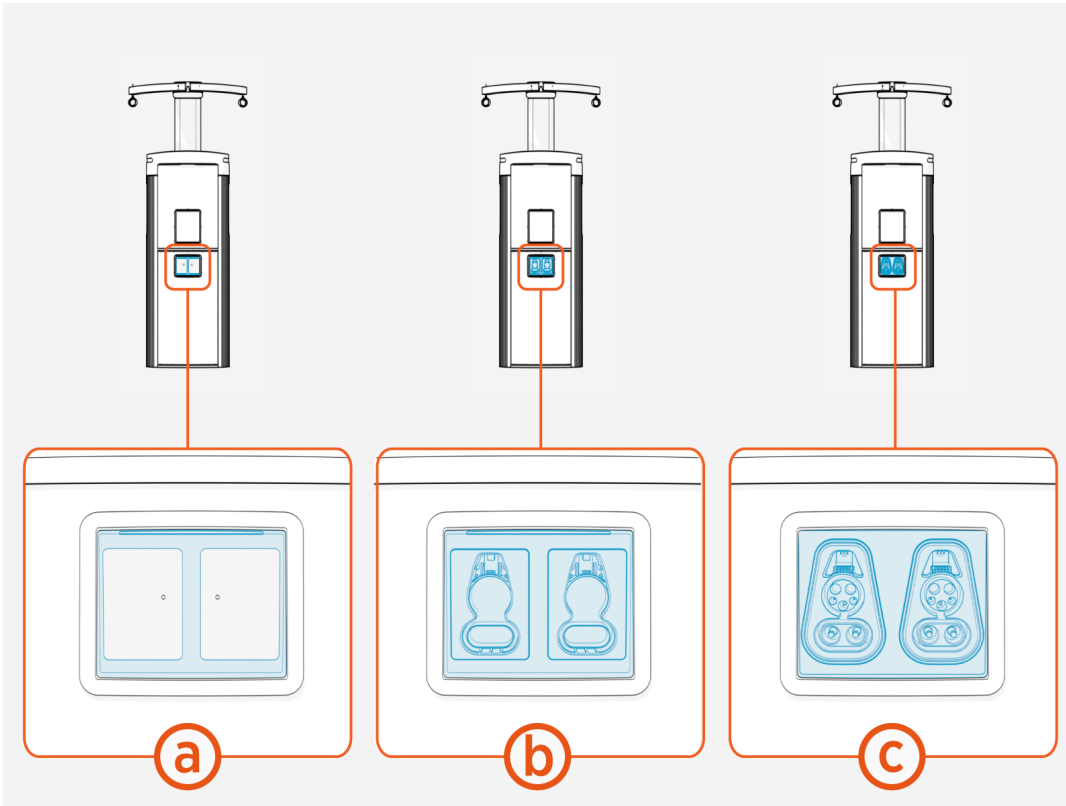

- (a)** With a holster bracket preinstalled (standard holsters must be field-installed into the bracket)
- (b)** With standard holsters and holster bracket preinstalled
- (c)** With Omni Port preinstalled

Install Standard Holsters

If the Power Link 2000 requires standard holsters but did not ship with them preinstalled, follow instructions in this section to install holsters.

1. Find the holster shipped with the charging cable.
2. Align and seat the holster onto the holster bracket.

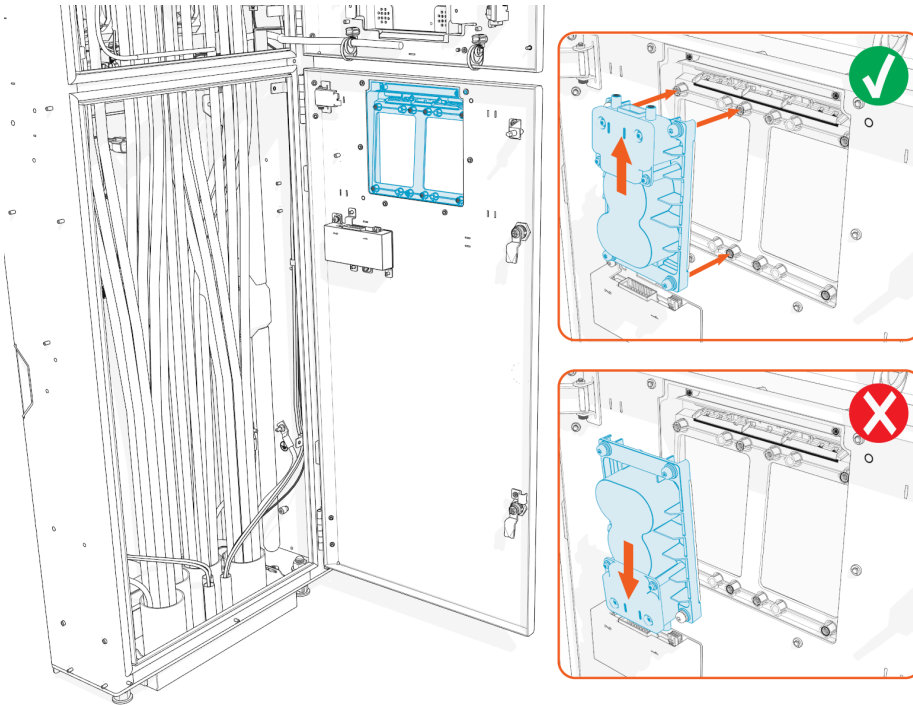

3. Torque the screws (x4) to **2.8 Nm (25 in-lb)**.

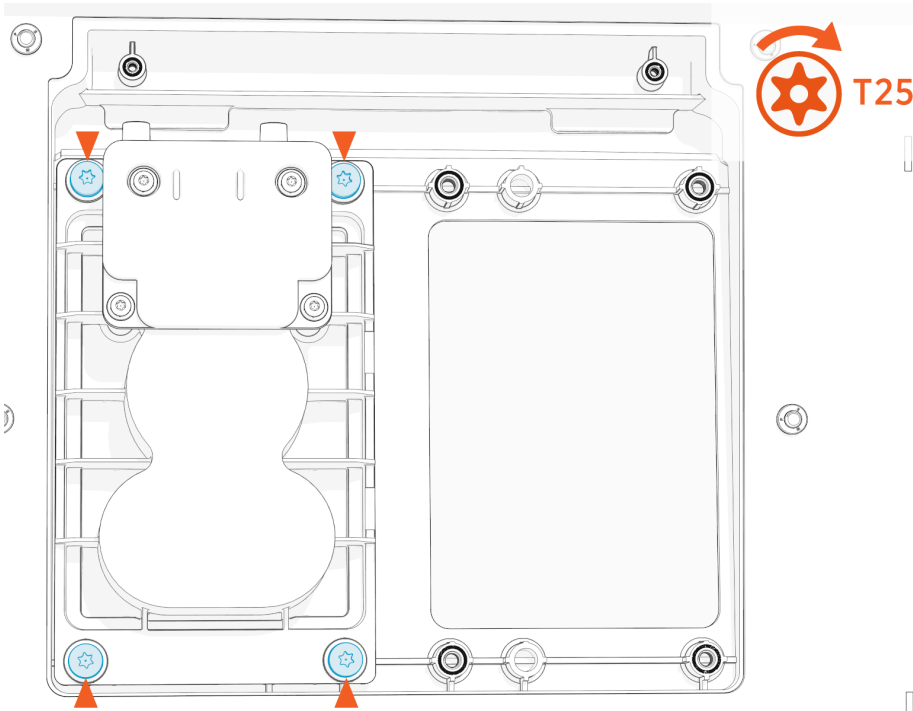

4. If the Power Link 2000 is configured with two charging cables, repeat the above procedure to install a second holster.

Install Omni Port

If the Power Link 2000 requires configuration with Omni Port but did not ship with one preinstalled, follow instructions in this section to install the Omni Port.

Mount Omni Port

1. Unpack the Omni Port package. Confirm all parts listed below are present.



NOTE: For any missing component, contact chargepoint.com/support.

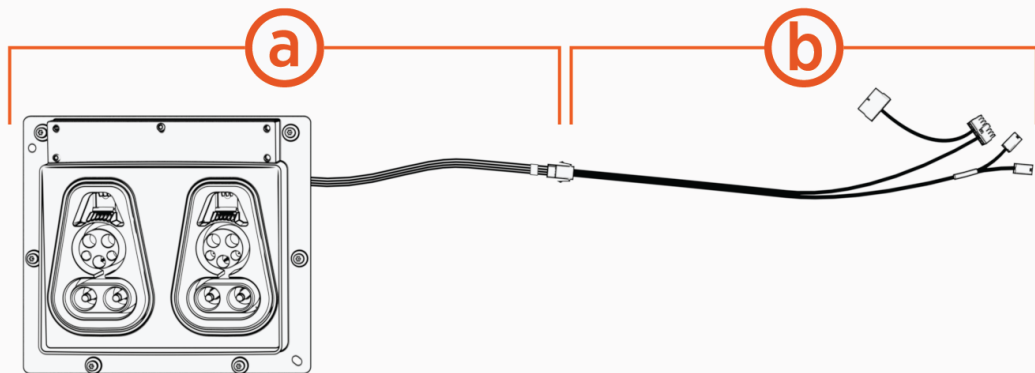

(a) Omni Port assembly with cable

(b) Pigtail cable

2. If the Power Link 2000 shipped with a standard holster bracket preinstalled, remove screws (x6) and remove the holster bracket.

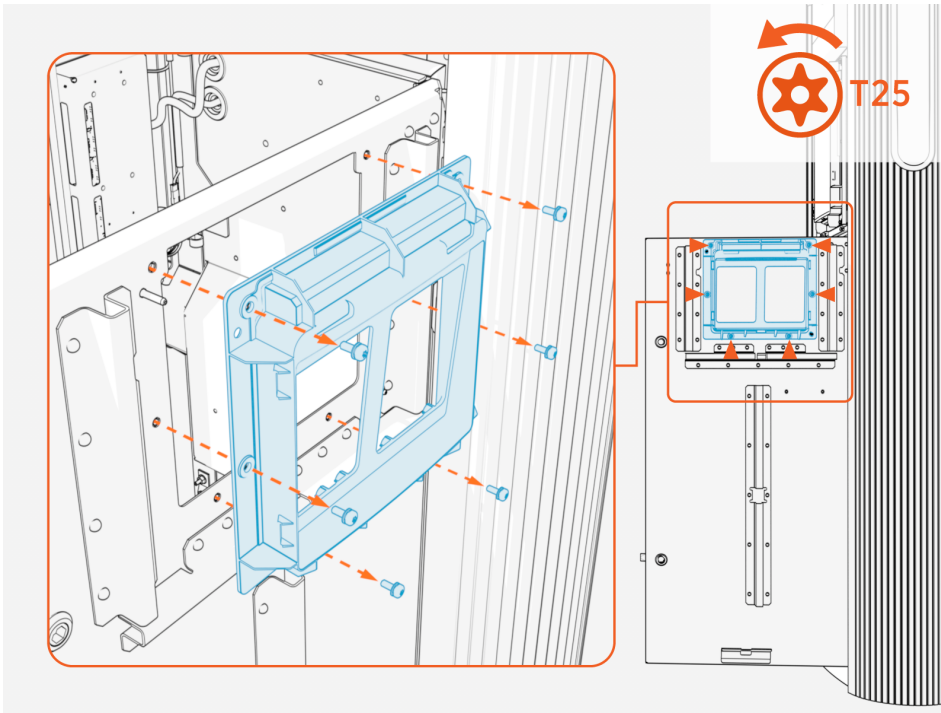

3. Align and seat the Omni Port assembly into the holster opening.

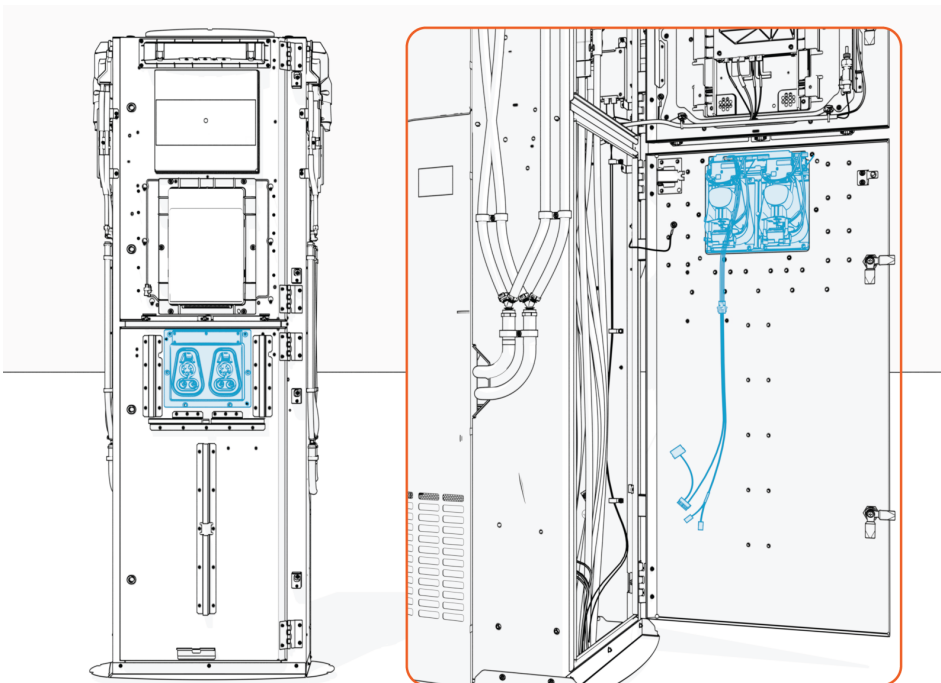

4. Install screws (x6). Torque to **4.5 Nm (40 in-lb)**.

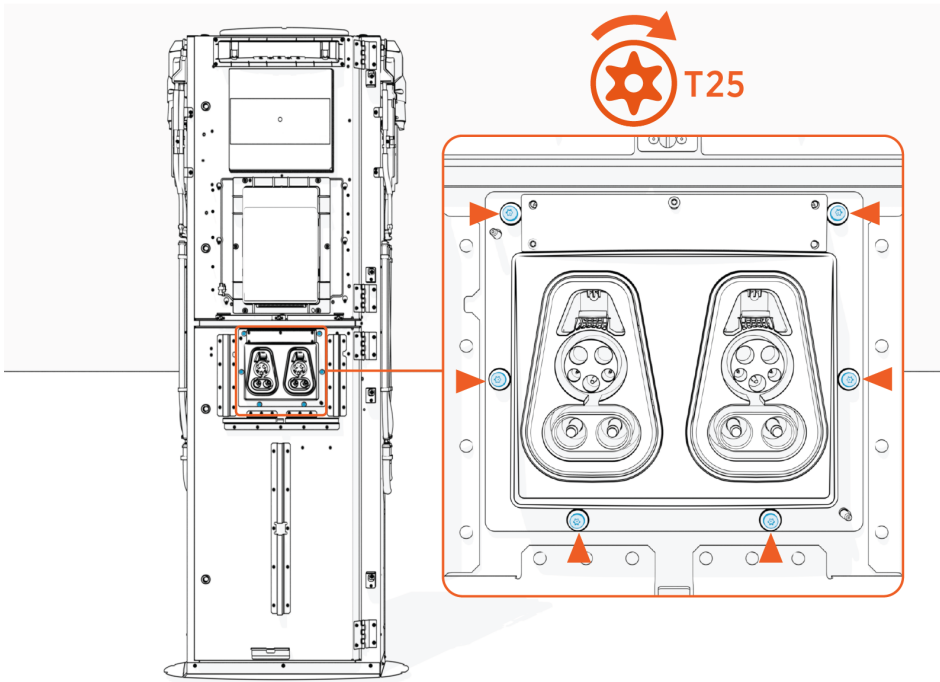

Connect Omni Port wires

To connect Omni Port wires, complete the following steps:

1. Disconnect and remove the Omni Port pigtail cable. The pigtail cable is not needed.

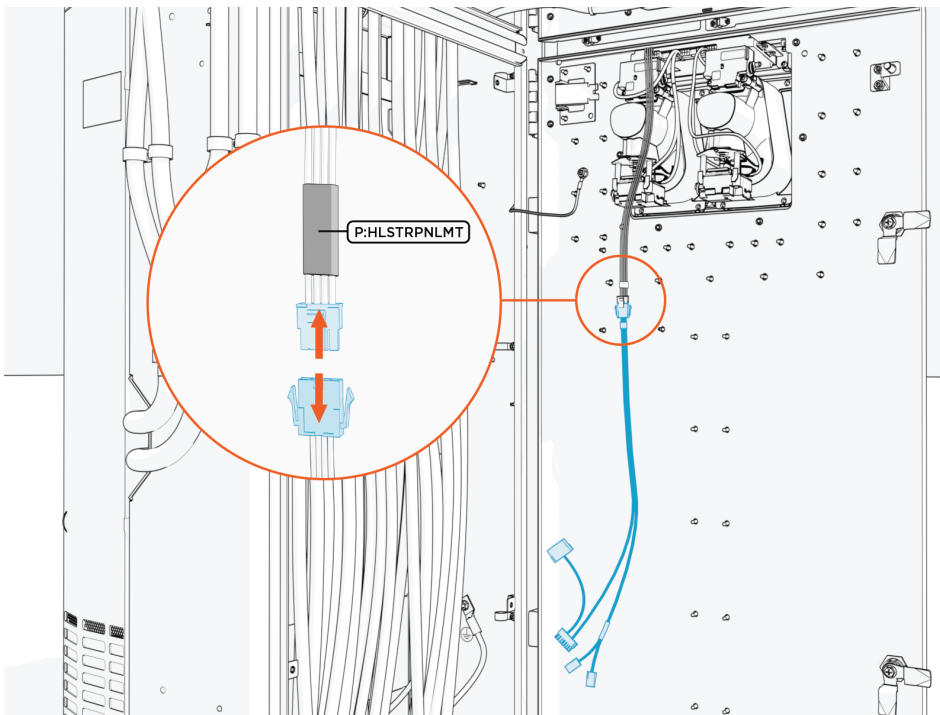

2. Route the Omni Port cable harness to reach the main cable harness on the Power Link 2000 door.



IMPORTANT: The cable harness must route behind the mid-height brace and through the door cable guide to prevent the cable from being pinched when closing the door.

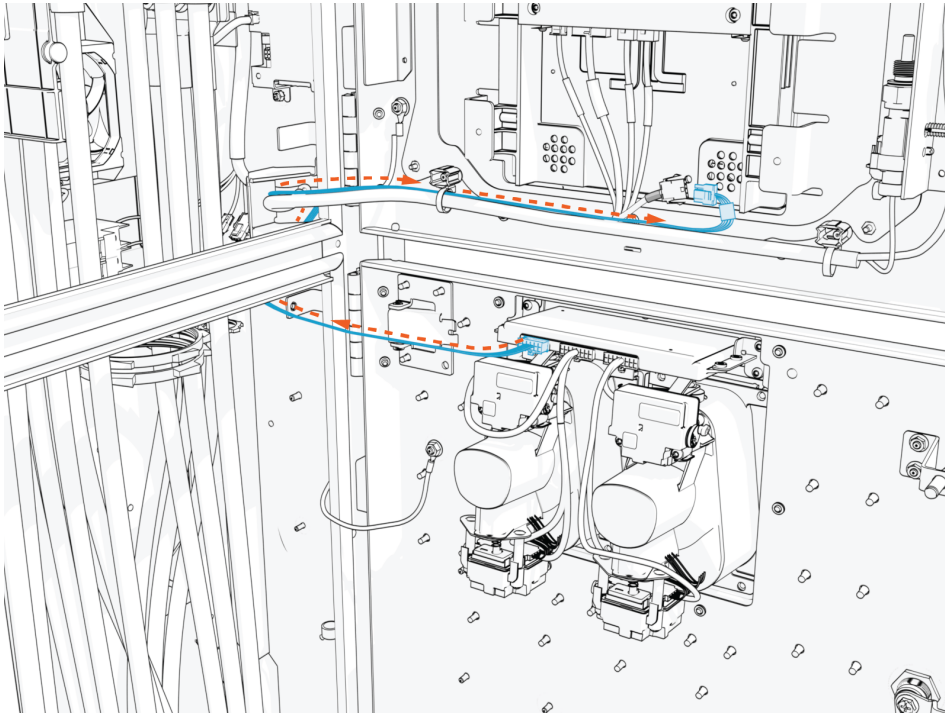

3. Connect the Omni Port cable harness to the main cable harness.



NOTE: The cables are labeled as shown below. The latch must snap onto the receptacle connector with a click to ensure the connection is secure.

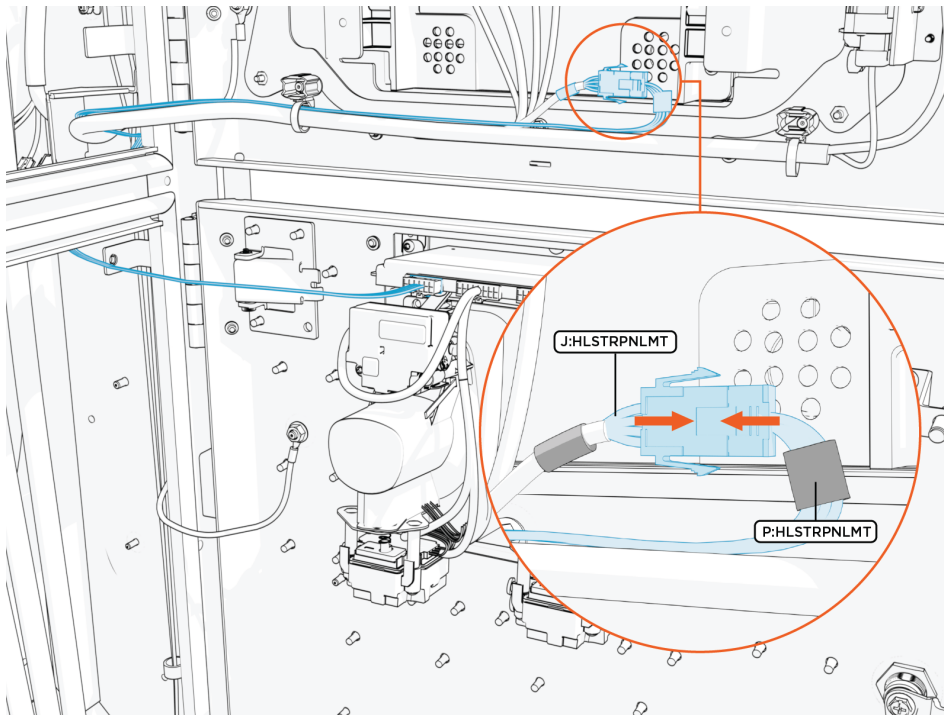

4. Use zip ties to secure the Omni Port cables to the main cable harness.



IMPORTANT: Pull excess cable into the Power Link 2000 pedestal to ensure there is no loose wire hanging from the door. Loose wires may get pinched when closing the door.

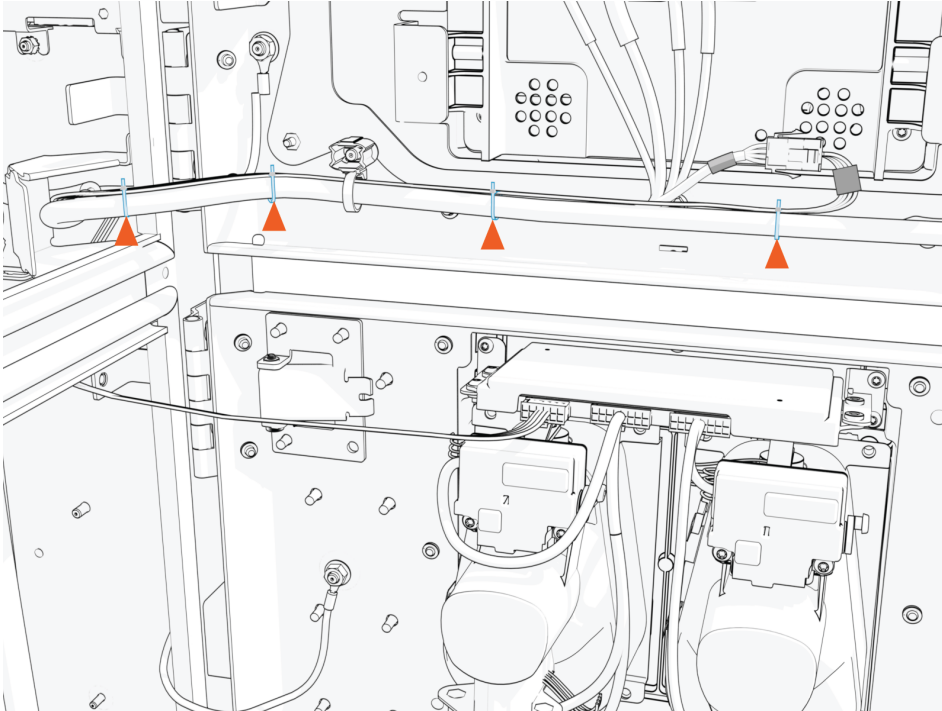

5. Check that the lower door can close properly.



IMPORTANT: The rear side of the Omni Port should not touch the DC power path wires within the Power Link 2000 pedestal when the door is closed. If needed, adjust the DC power path wires to avoid such contact.

Install Cable Management Kit 6

The Power Link 2000 can be installed with standard cable management kit (CMK), tall CMK, or overhead CMK for managing different length charging cables. Depending on the space or clearance available above the Power Link 2000, the standard and tall CMK may be installed at one of two height settings, a minimum or maximum height.

CMK Type	Compatible Charging Cable Length	Installation Height	
		Minimum	Maximum
Standard	Standard length (up to 5.8 m or 19 ft)	2.21 m (7 ft 3 in)	2.41 m (7 ft 11 in)
Tall	Medium length (7.6 m or 25 ft)	2.41 m (7 ft 11 in)	3 m (10 ft)
Overhead		-	-

Access the Preinstalled CMK Mast



IMPORTANT: Power Link 2000 with LCC ships with a CMK mast preinstalled at maximum height. If the minimum height is needed, follow instructions given in this section to remove the side panels and upper rear cover of the Power Link 2000. This provides access to adjust the CMK mast position. Otherwise, skip this step.

Remove Side Panels

To remove the side panels, complete the following steps:

1. Loosen the screws (x2).

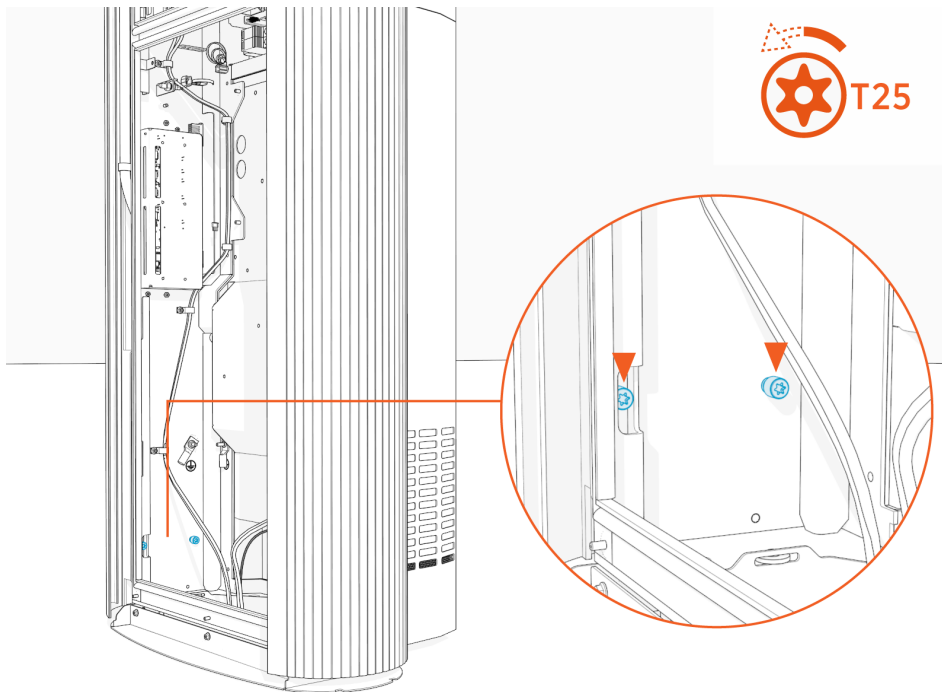

2. Slowly push upper side of the side panel up to disengage it from hooks (x2) on the frame.

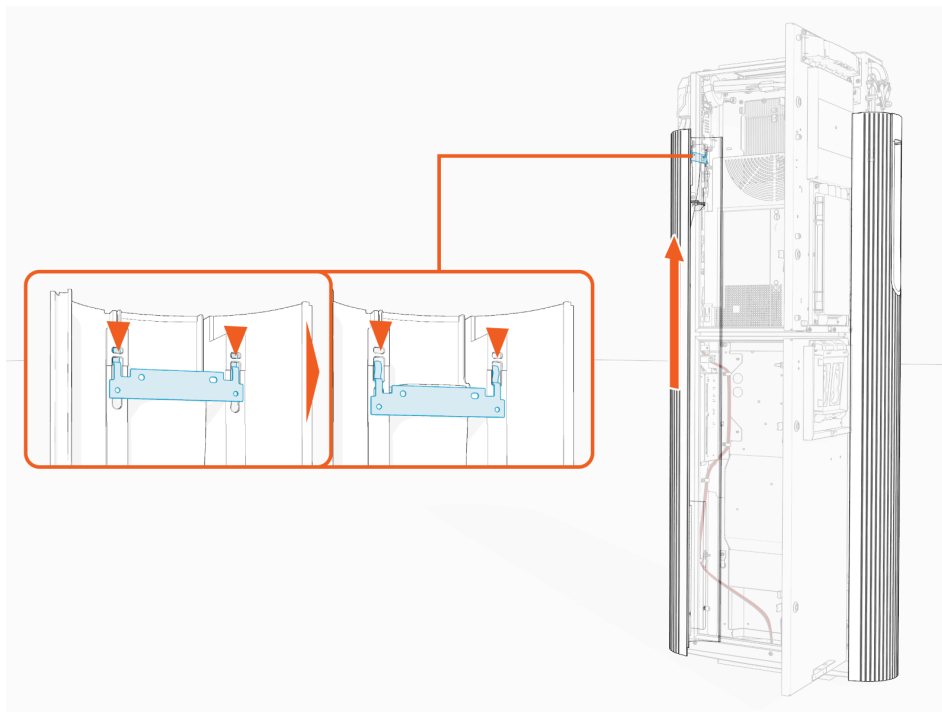

3. Remove the side panel and keep it aside to reinstall it later.

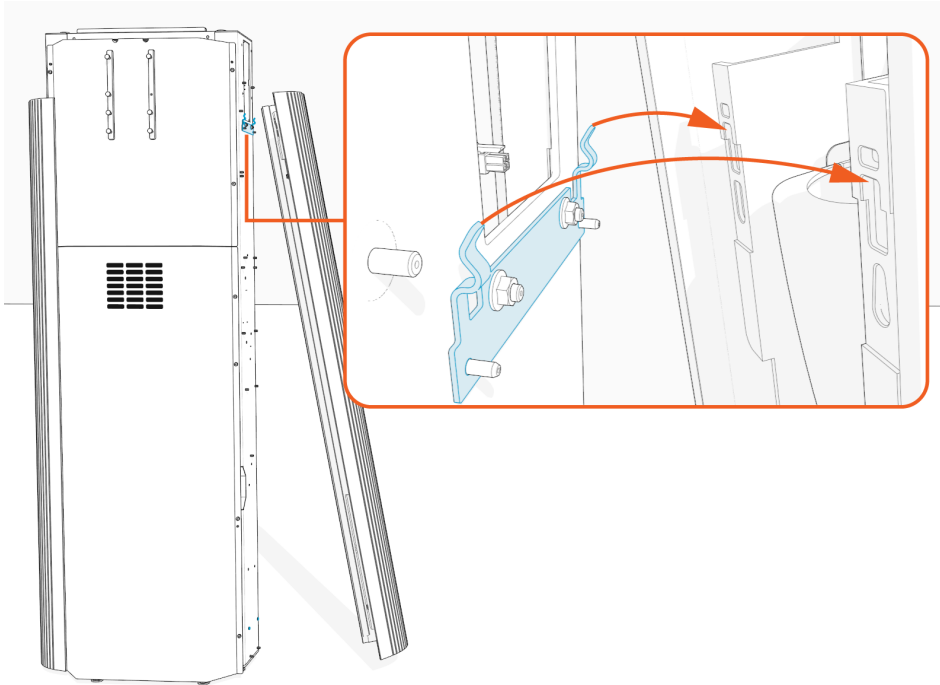

Remove Rear Upper Cover

To remove the rear upper cover, loosen the screws (x6) to remove the rear upper cover.

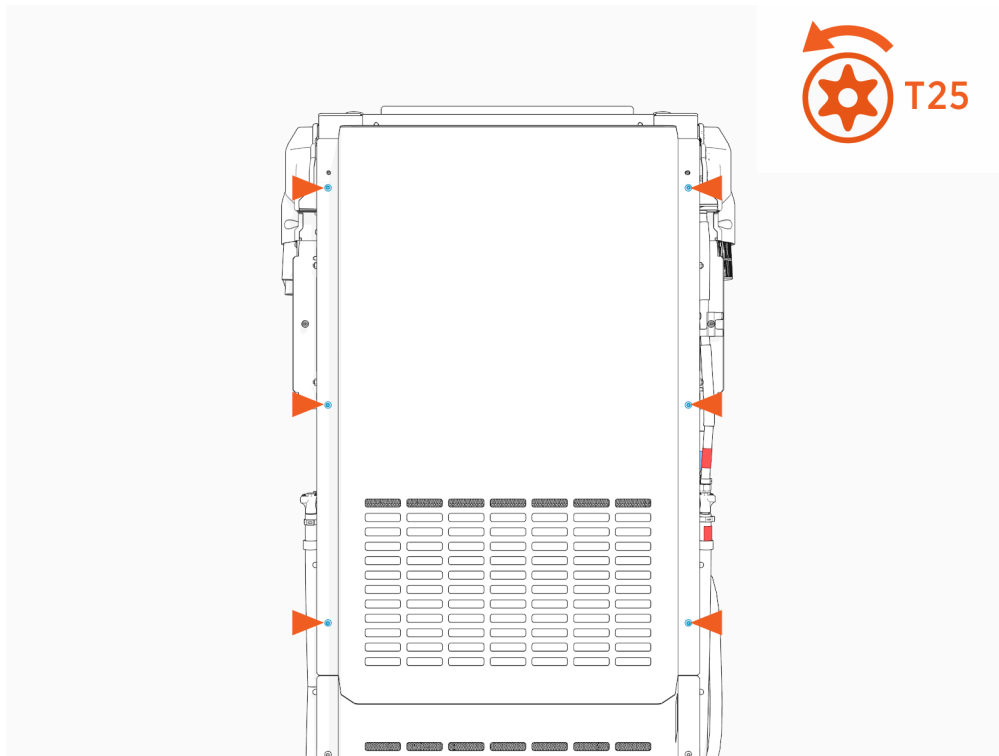

Install Standard CMK

If the site plan calls for the Power Link 2000 to be configured with a standard CMK, follow procedures in this section to install the CMK.

Kit Components

Check the standard CMK package for the following components:



NOTE: For any missing component, contact ChargePoint support at chargepoint.com/support.

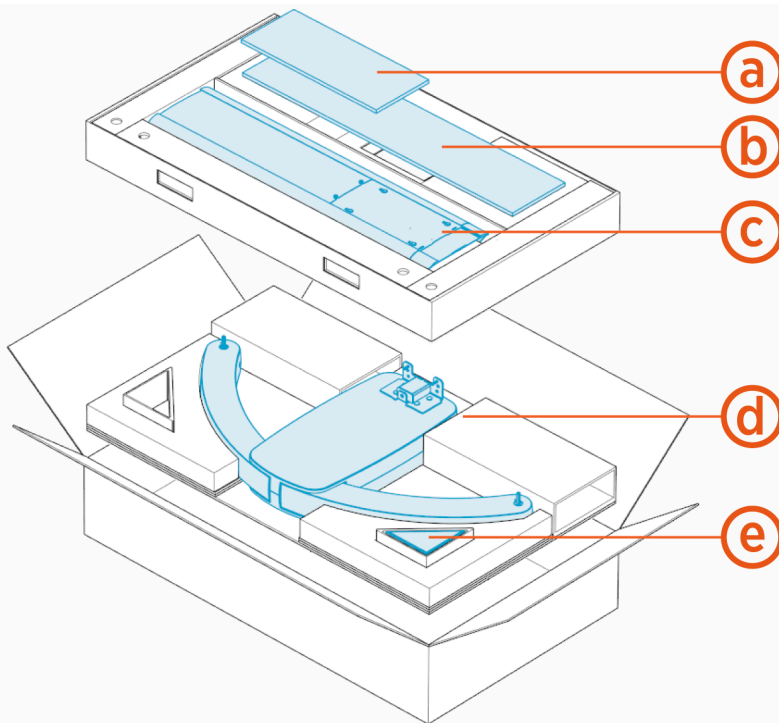

- (a) Front cover
- (b) Rear cover
- (c) Mast
- (d) Single or dual swingarm assembly
- (e) M6 Torx screws (x5)

Install Mast



NOTE: The principles and procedures outlined in this section may be used to install a mast or to adjust the height of a preinstalled CMK mast.

1. Loosen the preinstalled screws if they are not loose. Hook the mast to the screws.
To install CMK at maximum height, the mast hooks onto eight preinstalled screws.

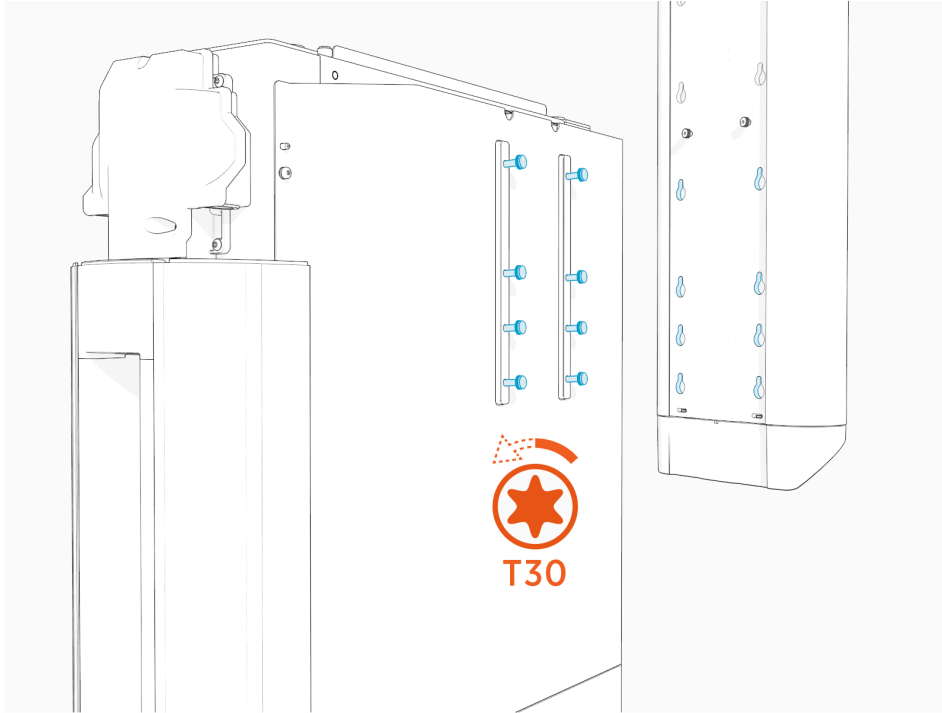

To install CMK at minimum height, do the following:

- a. Remove these preinstalled screws (x2 from the rear of the Power Link 2000 and x2 from the front of the mast).

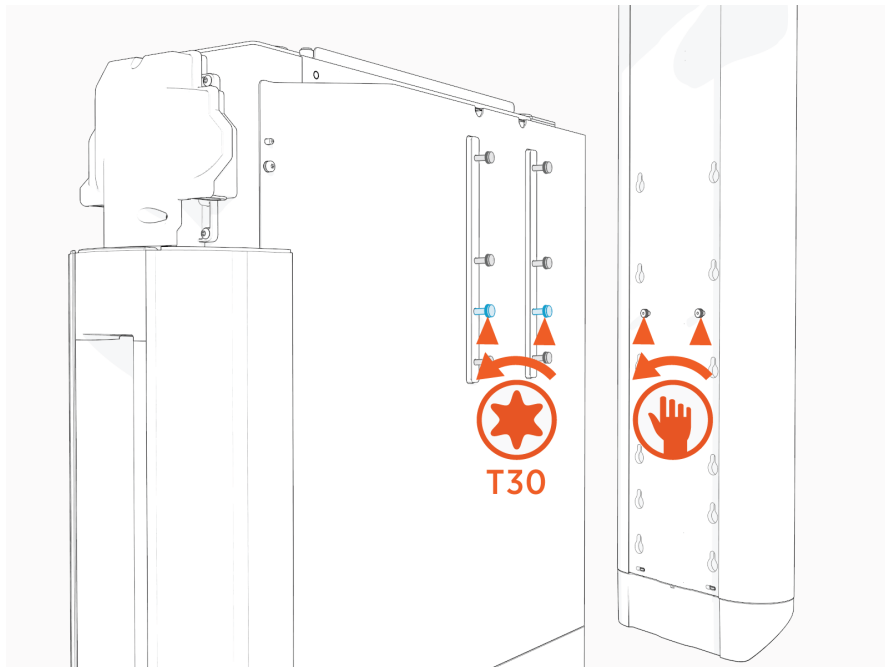

b. Loosen and hook the mast to the remaining screws (x6).

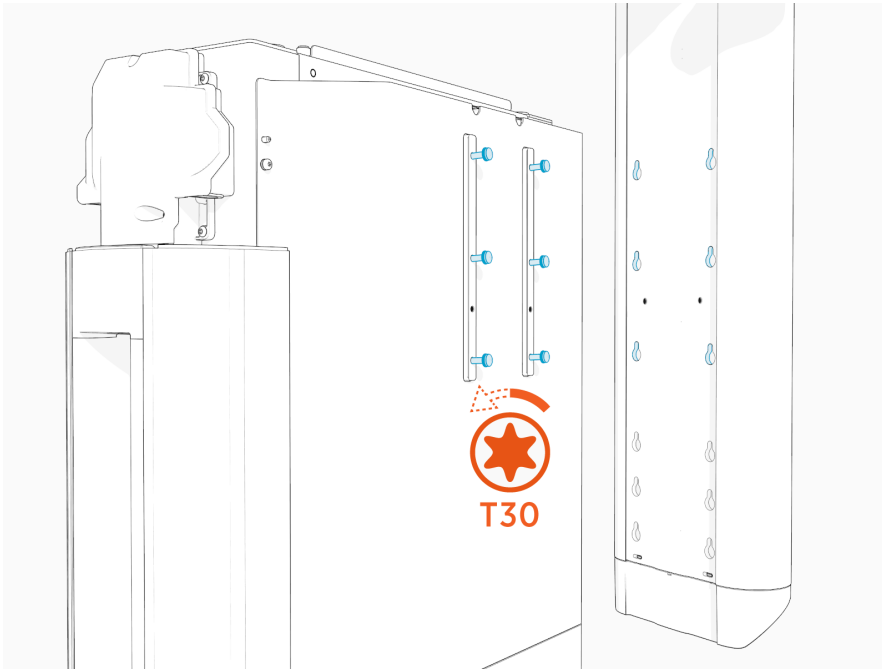

2. Torque loosened screws to **5.6 Nm (50 in-lb)** through the screw holes at the back of the mast.

Maximum height:

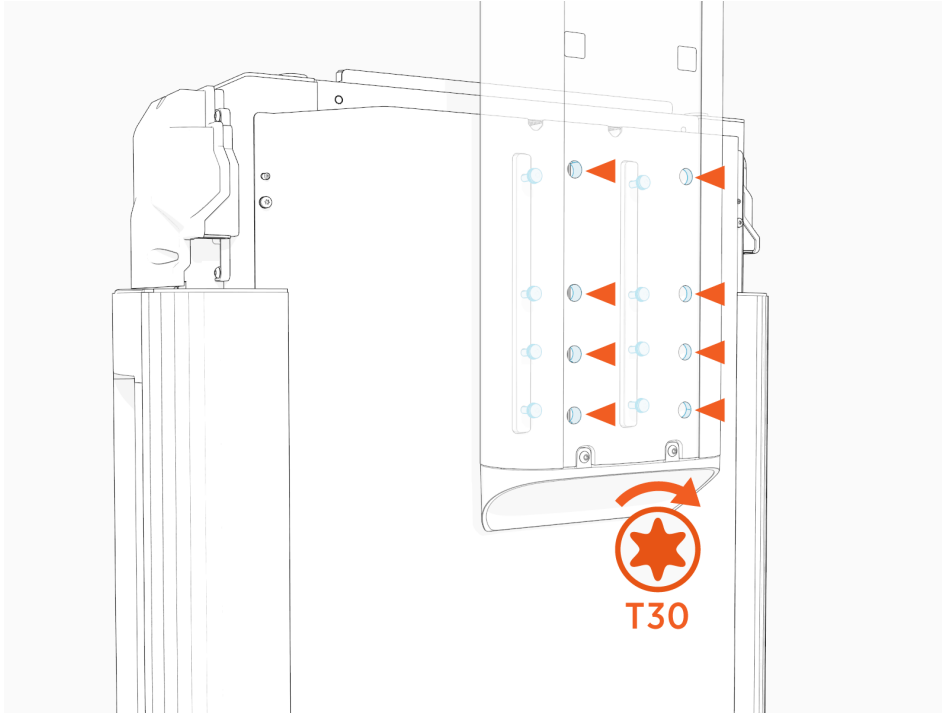

Minimum height:

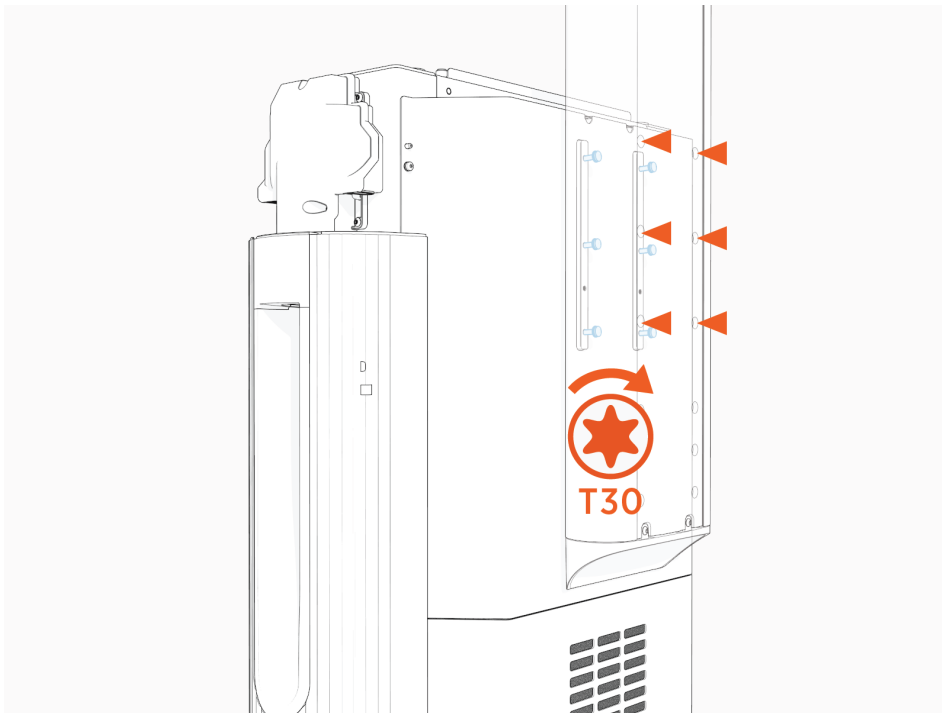

Install Swingarm Assembly

To install the swingarm assembly, complete the following steps:

1. Find the M6 Torx screws (x5) shipped in the standard CMK package.
2. Install the swingarm assembly onto the mast.

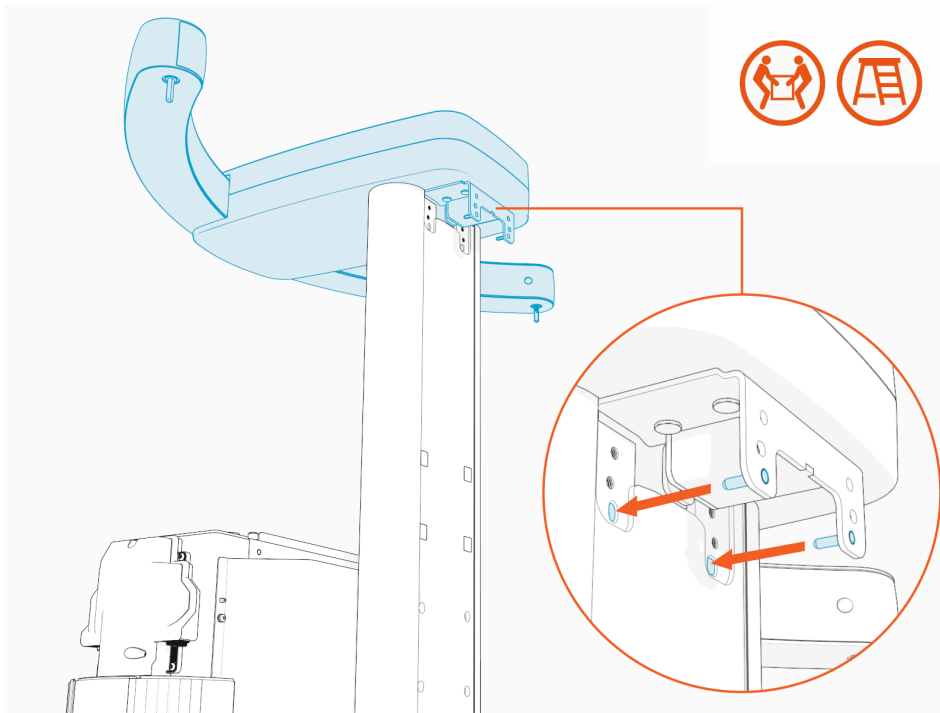

3. Install the M6 Torx screws (x5) (x4 at rear and x1 at front) and torque to **5.6 Nm (50 in-lb)**.

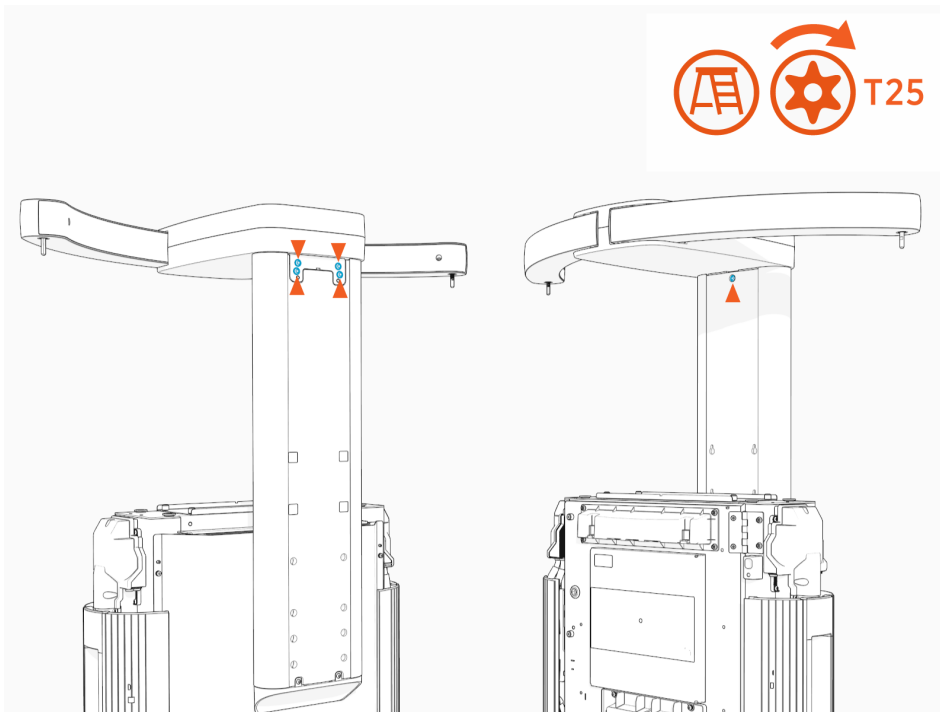

4. Suspend charging cable.
5. Install covers.

Install Tall CMK

If the site plan calls for the Power Link 2000 to be configured with a tall CMK, follow procedures in this section to install the CMK.

Kit Components

Check the tall CMK package for the following components:



NOTE: For any missing component, contact ChargePoint support at chargepoint.com/support.

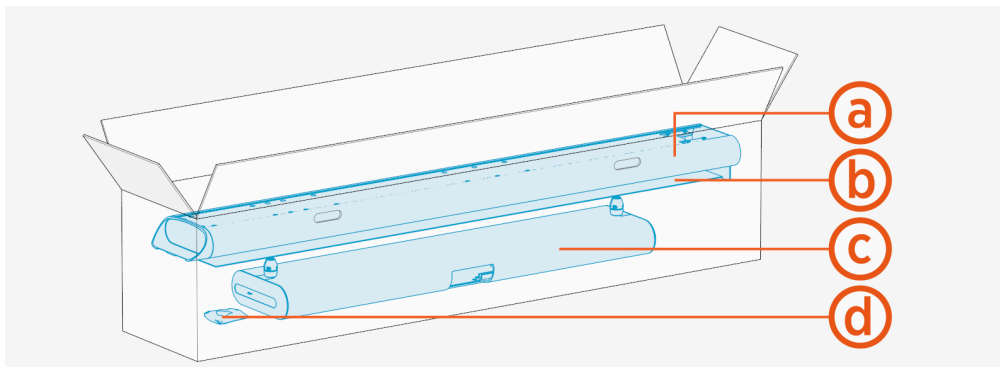

- (a) Mast
- (b) Front and rear covers
- (c) Single or dual tall CMK assembly
- (d) M6 Torx screws (x8) and M10 hex screws (x4)

Install Mast



NOTE: The principles and procedures outlined in this section may be used to install a mast or to adjust the height of a preinstalled CMK mast.

1. Loosen the preinstalled screws if they are not loose, and hook the mast to the screws.
To install CMK at maximum height, the mast hooks onto eight preinstalled screws.

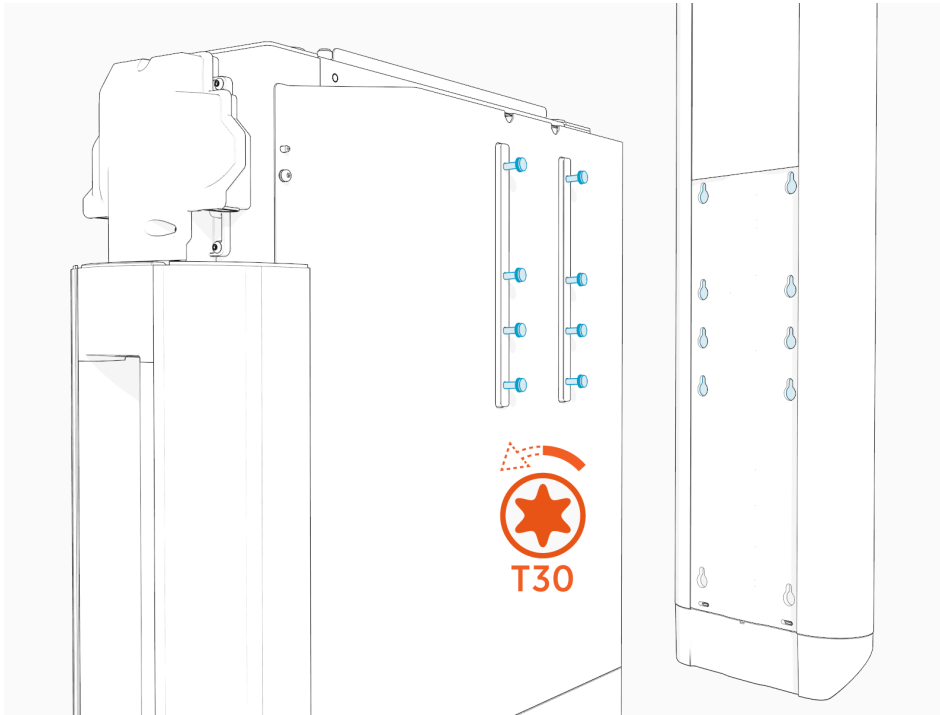

To install CMK at minimum height, do the following:

- a. Remove these preinstalled screws (x2) from the rear of the Power Link 2000.

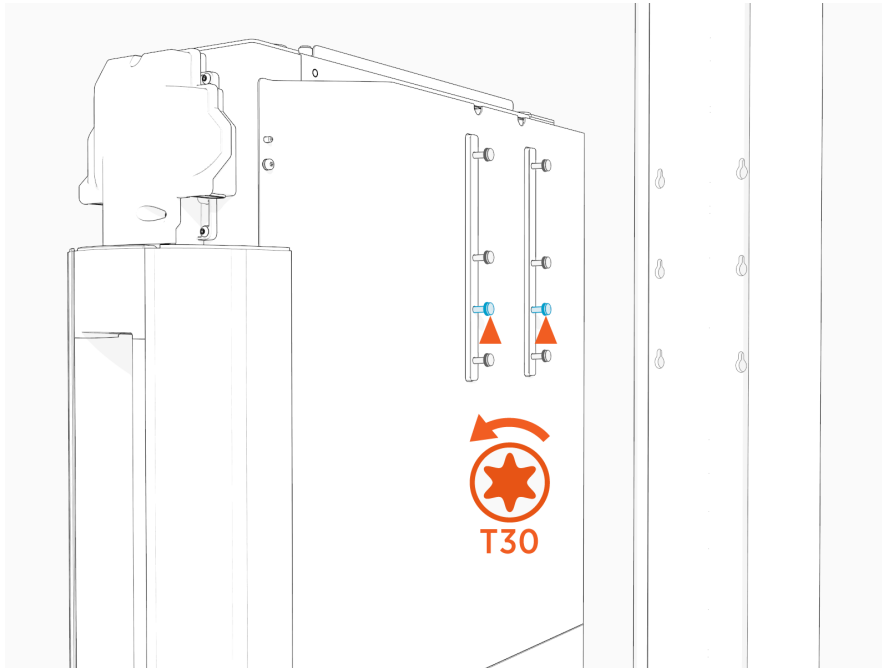

- b. Loosen and hook the mast to these screws (x6).

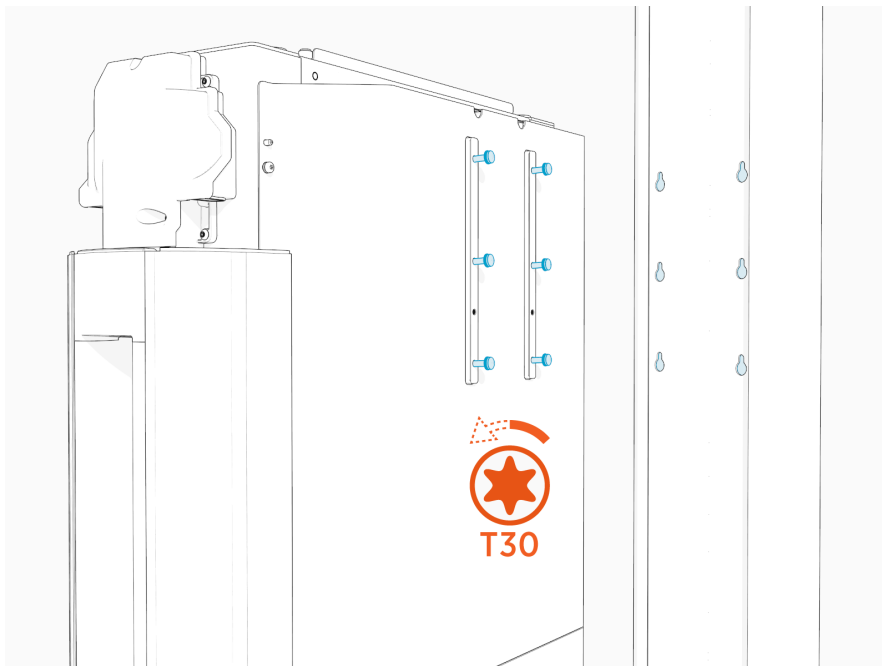

2. Torque loosened screws to **5.6 Nm (50 in-lb)** through the screw holes at the back of the mast.
Maximum height:

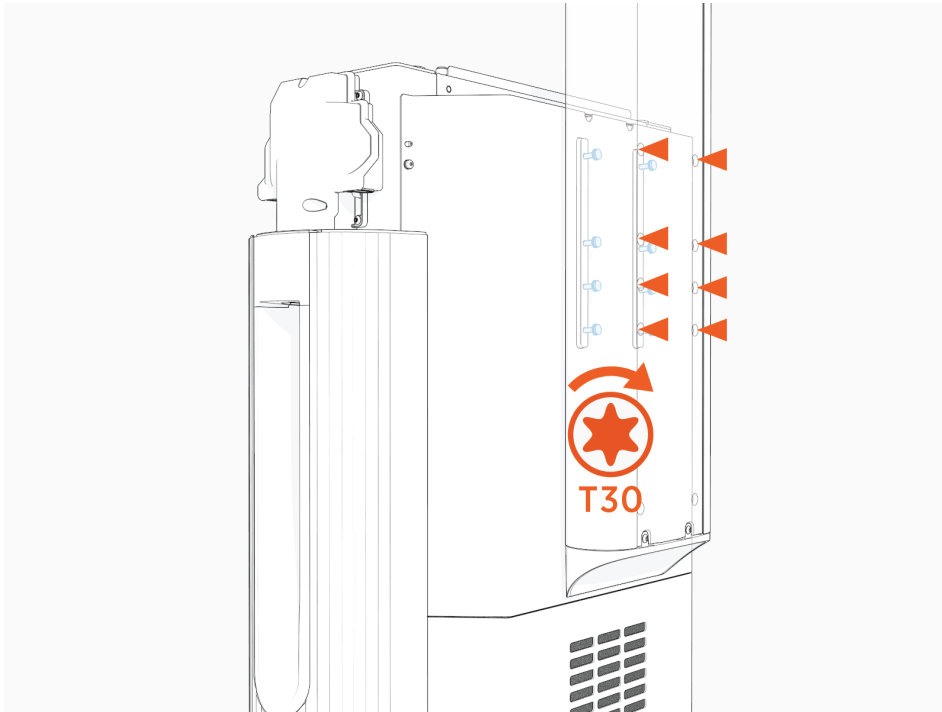

Minimum height:

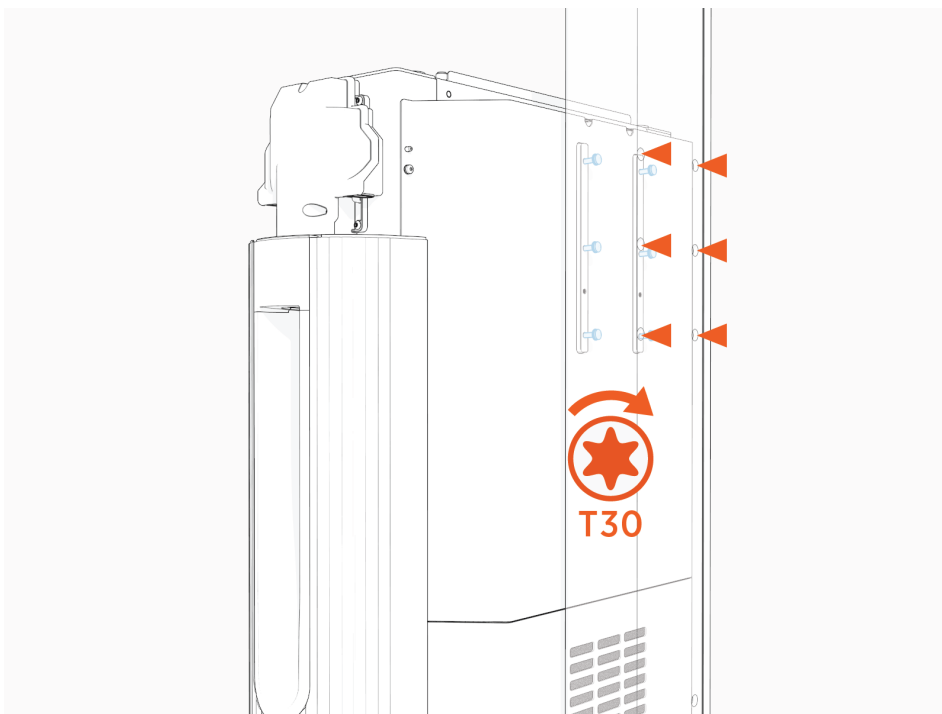

Install Tall CMK Assembly

To install the tall CMK assembly, complete the following steps:

1. Find the M10 hex screws (x4) shipped in the tall CMK package.
2. Install the tall CMK assembly onto the mast.

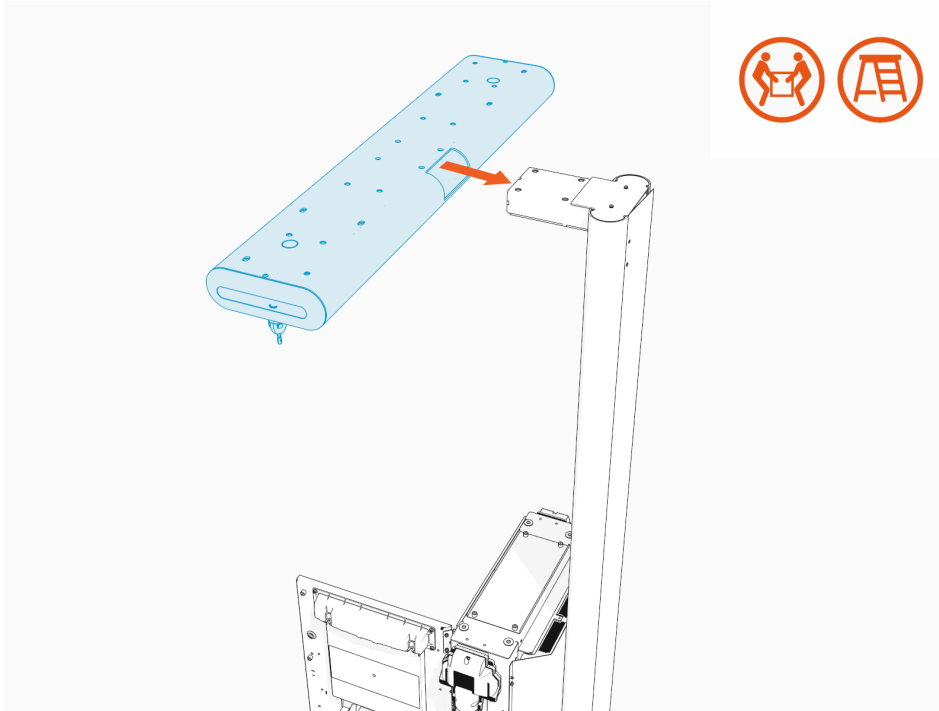

3. Install the M10 hex screws (x4) and torque to **13.5 Nm (120 in-lb)**.

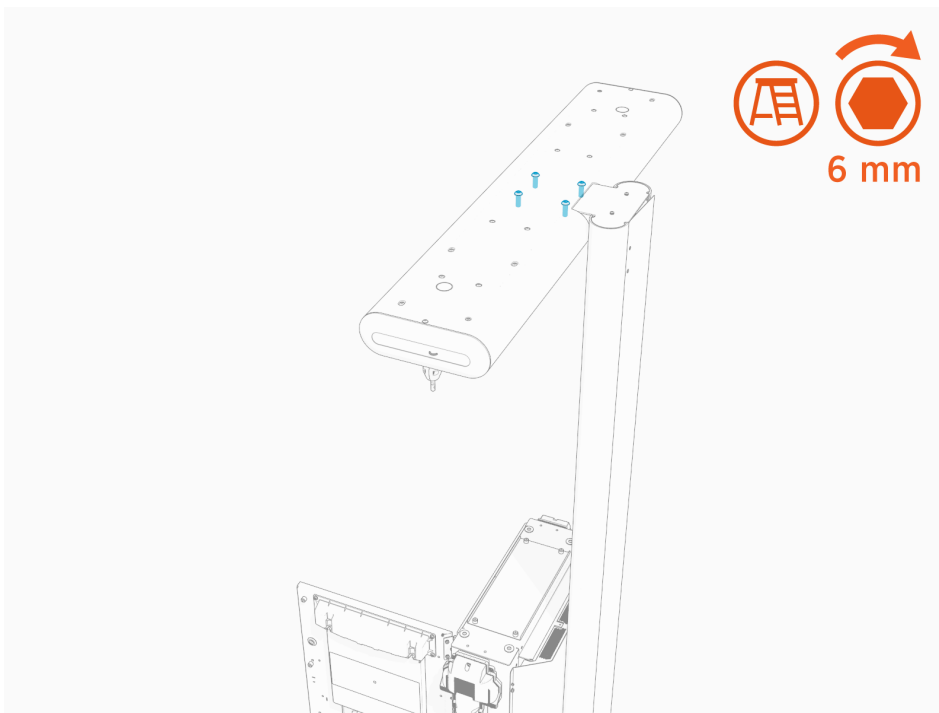

4. Install tetherball onto the charging cable.

5. Suspend charging cable.
6. Install covers.

Install Overhead CMK

If the site plan calls for the Power Link 2000 to be configured with an overhead CMK, follow procedures in this section to install the CMK.



IMPORTANT: To install the overhead CMK for a pedestal-mount Power Link 2000, the site must be equipped with a pole for mounting the overhead CMK next to each of the Power Link 2000 charging cables. The pole must meet the design specifications given in the *Express Distro Power Link 2000 Site Design Guide*, available at [ChargePoint Product Reference Documentation](#).

Kit Components

Check the overhead CMK package for the following components:



NOTE: For any missing component, contact ChargePoint support at chargepoint.com/support.

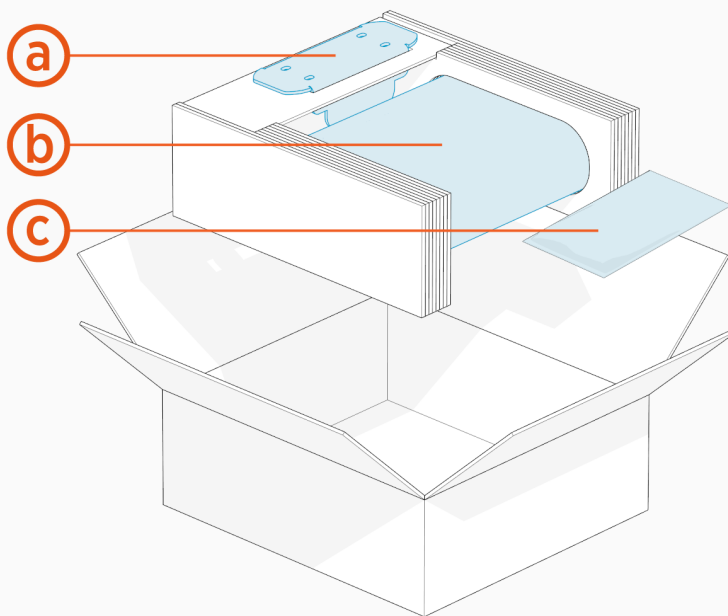

- (a) Mounting bracket
- (b) Overhead CMK
- (c) Hardware kit with M8 hex nuts (x4) and M6 Torx screws (x4)

Install Overhead CMK

To install the overhead CMK, complete the following steps:

1. Find the M8 hex nuts (x4) and M6 Torx screws (x4) shipped in the overhead CMK package.
2. Install the bracket onto the pole.

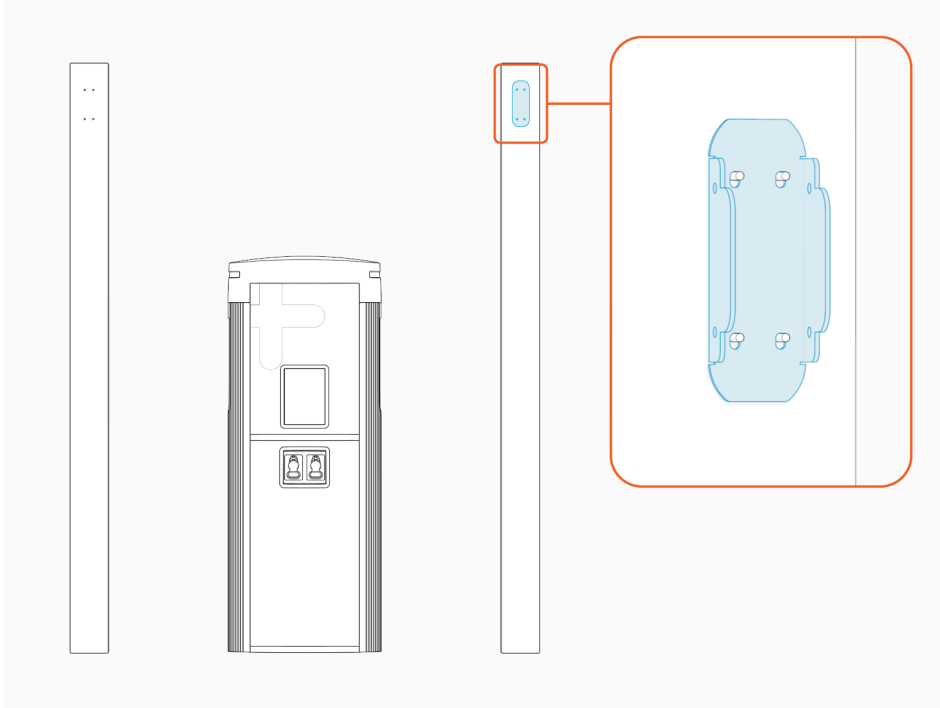

3. Install and torque the M8 hex nuts (x4) to **12.2 Nm (108 in-lb)** to secure the bracket.

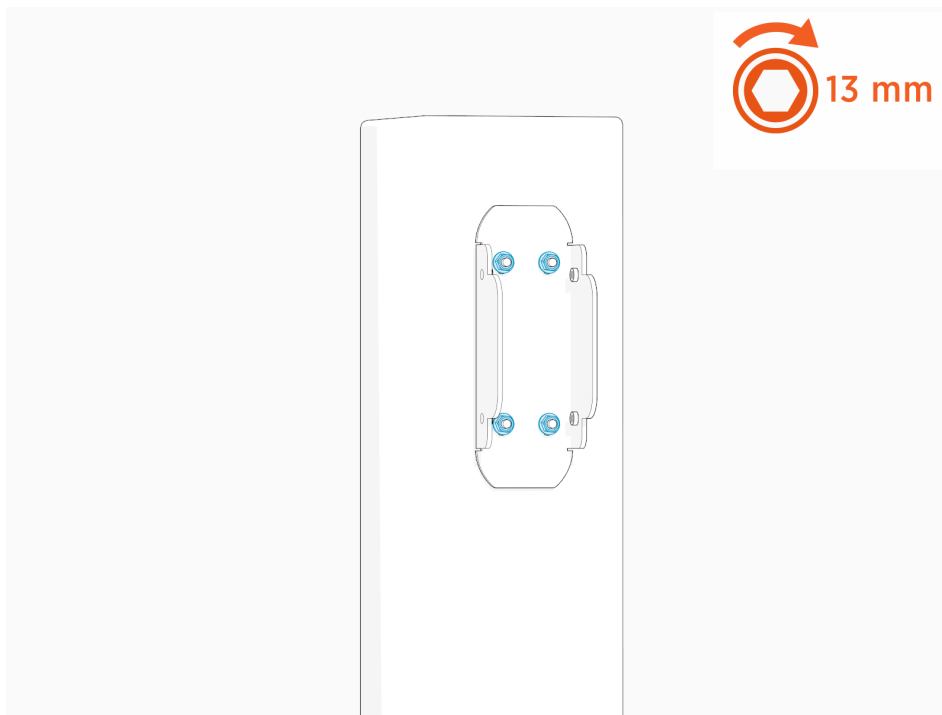

4. Align the overhead CMK onto the bracket and install the M6 Torx screws (x4): two on the left side and two on the right side.

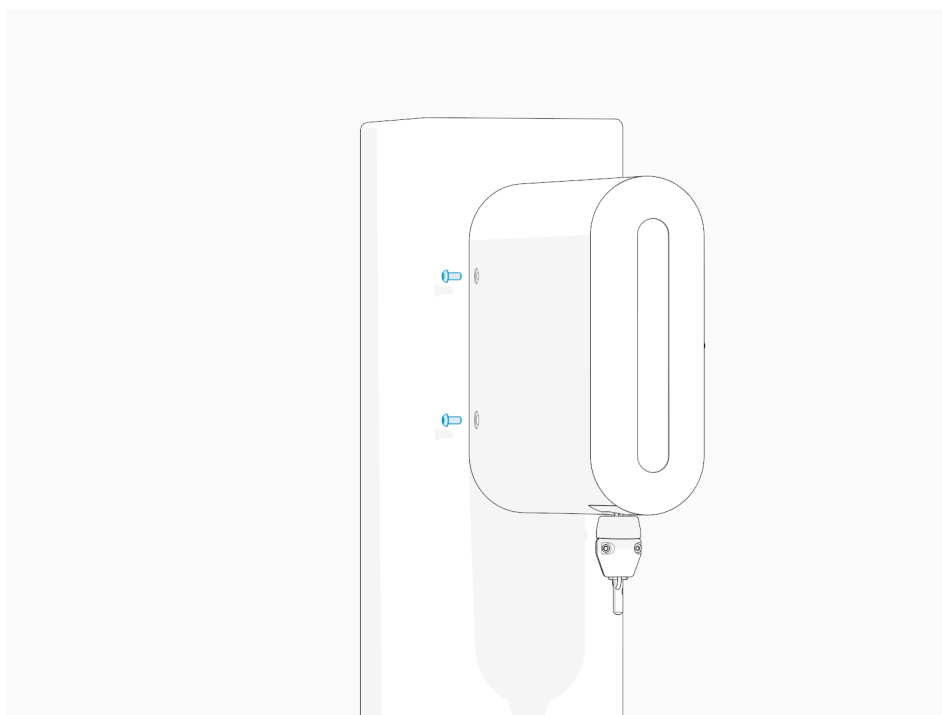

5. Torque the screws to **3.4 Nm (30 in-lb)**.

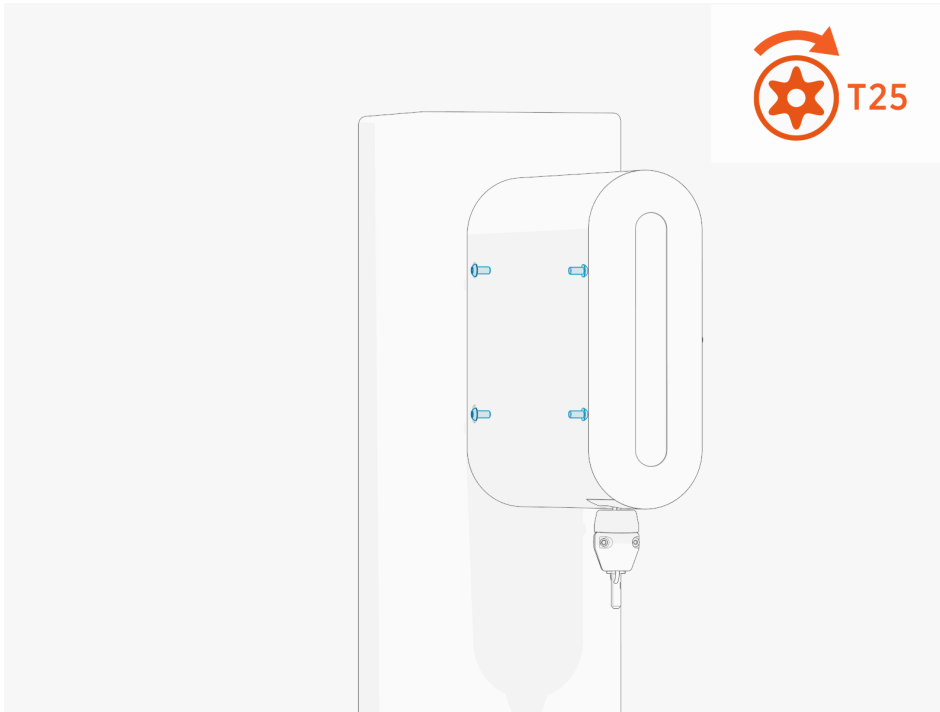

6. Install tetherball onto the charging cable.
7. Suspend charging cable.

Install Tetherball

Standard length (5.8 m or 19 ft) charging cables come with a tetherball preinstalled onto the cable. For non-LCC medium length (7.6 m or 25 ft) charging cables, a tetherball is not preinstalled onto the cable. It must be installed after installing the charging cable or while installing the CMK.

1. Loosely install the tetherball onto the cable.

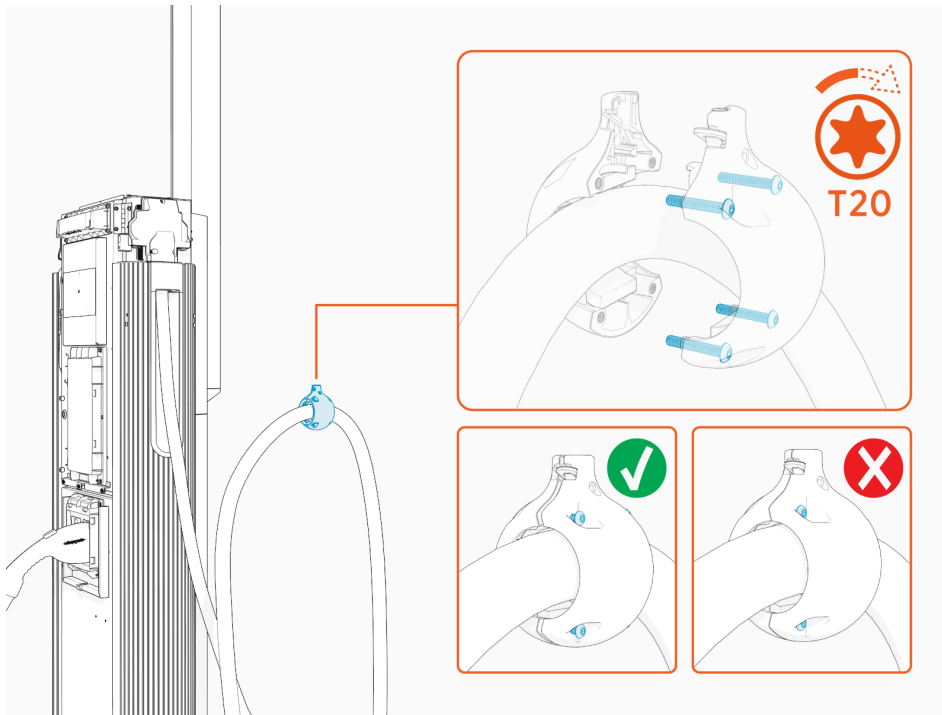

2. If necessary, slide the tetherball to a position on the cable such that the lowest point of the cable remains 25 mm (1 in) off the ground when the cable is in its stored position.

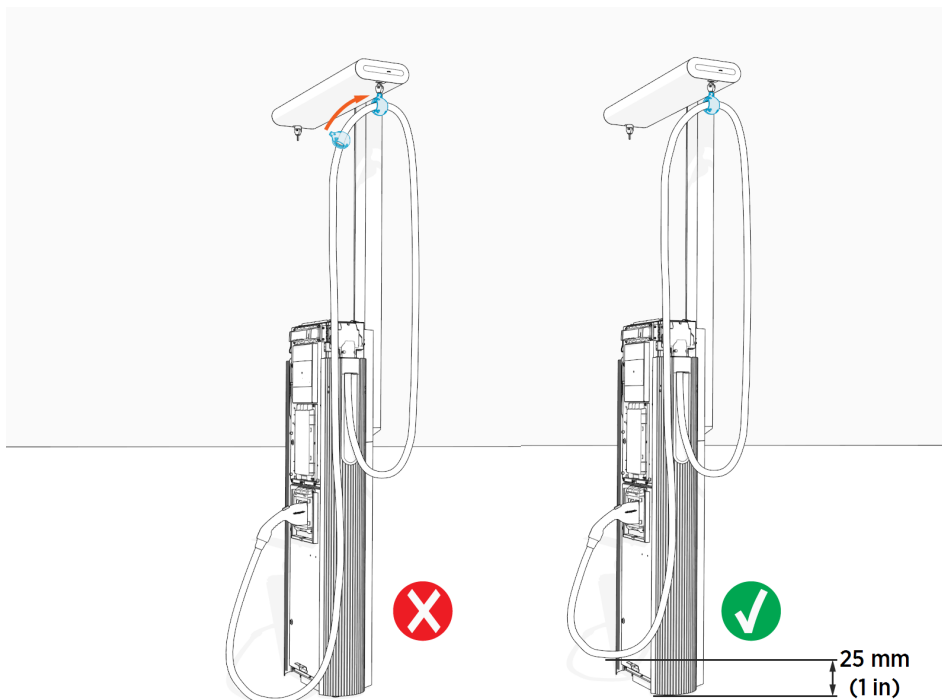

3. Torque the screws (x4) to **2.8 Nm (25 in-lb)**.

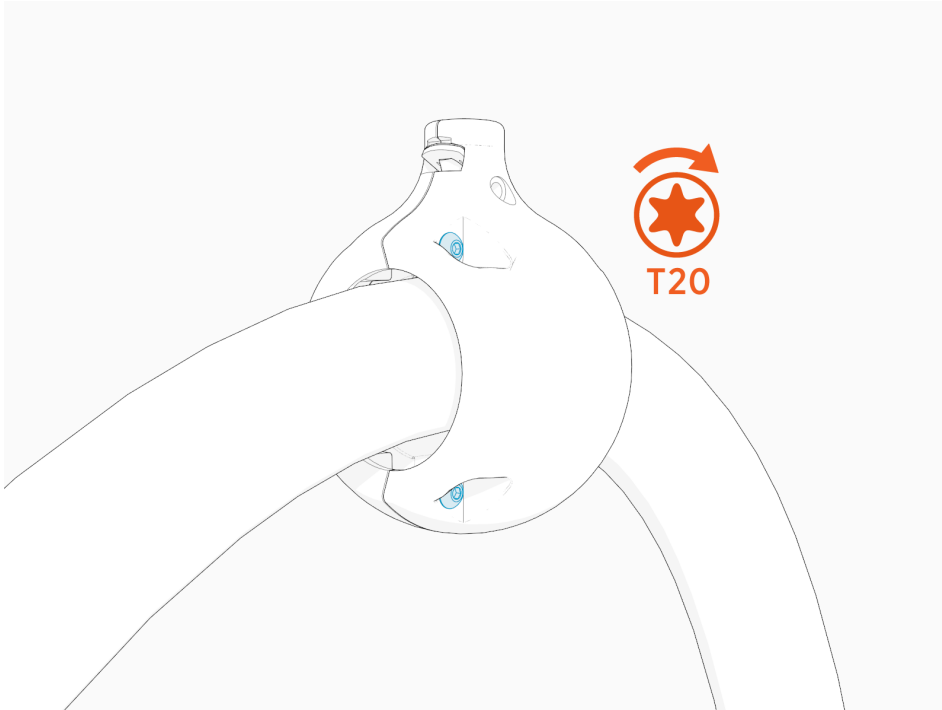

Suspend Charging Cable

To suspend the charging cable, complete the following steps:

1. Loosen the screw if it is not loose.

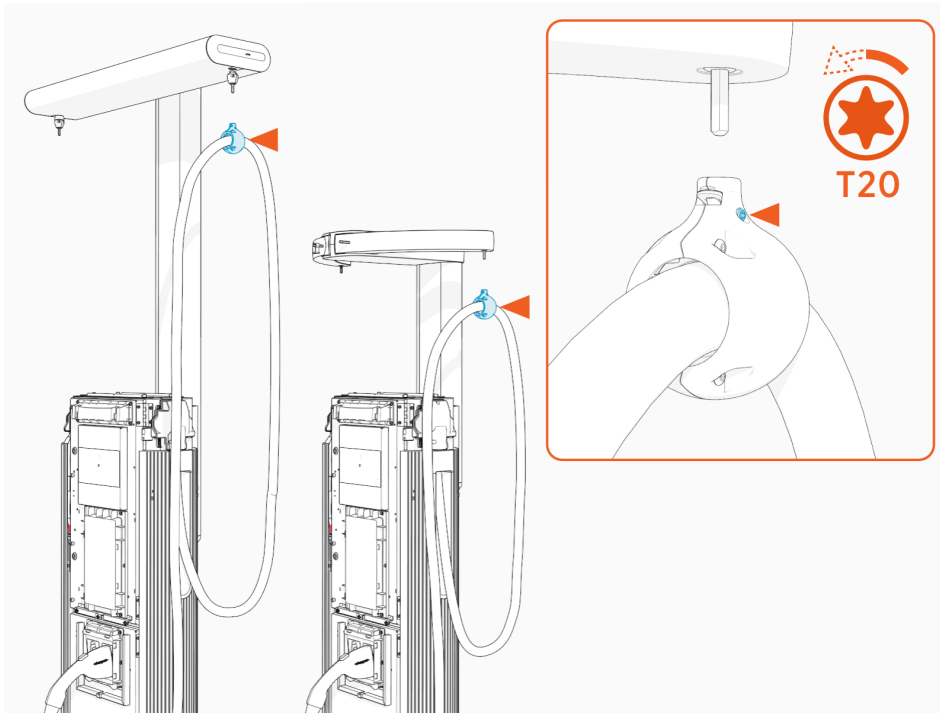

2. Align the spring tab in the tetherball with the flat notch on the tether pin. While aligned, gently push the tetherball onto the tether pin.

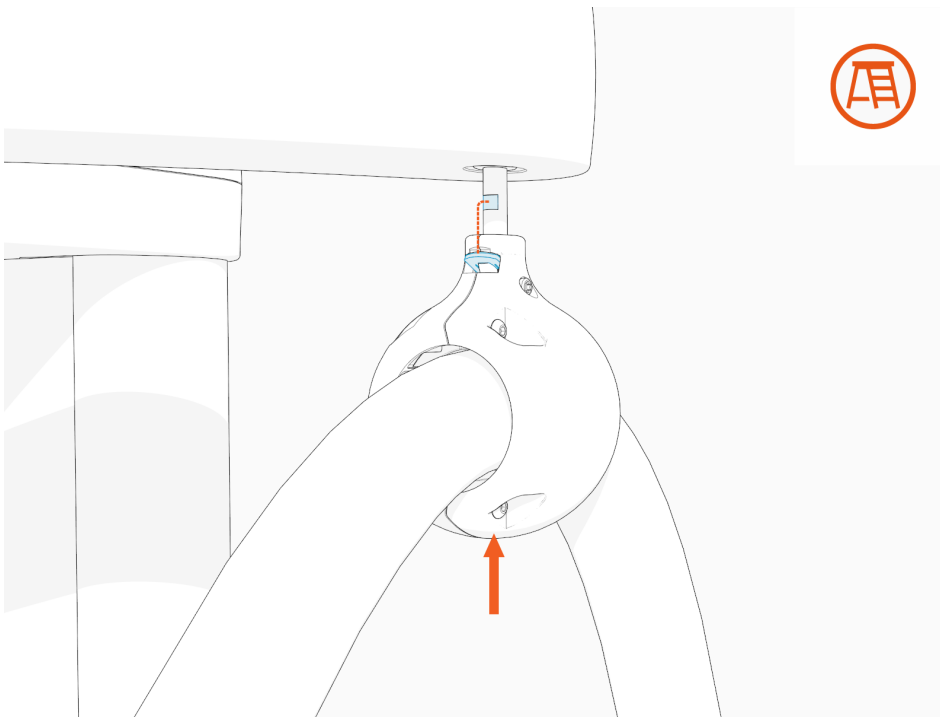

3. Torque the screw to **2.8 Nm (25 in-lb)**.

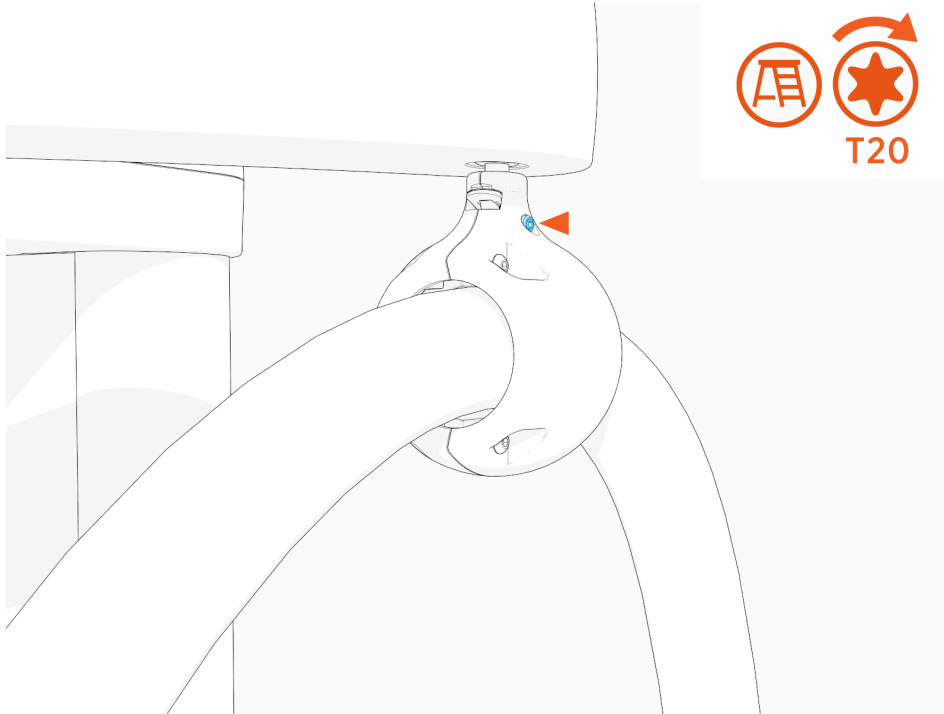

4. Tug on the cable to check that it is securely attached and the swingarm or tool balancer is functioning. If you find limited motion or retraction, contact ChargePoint support at chargepoint.com/support.

- Standard CMK swingarm extension:

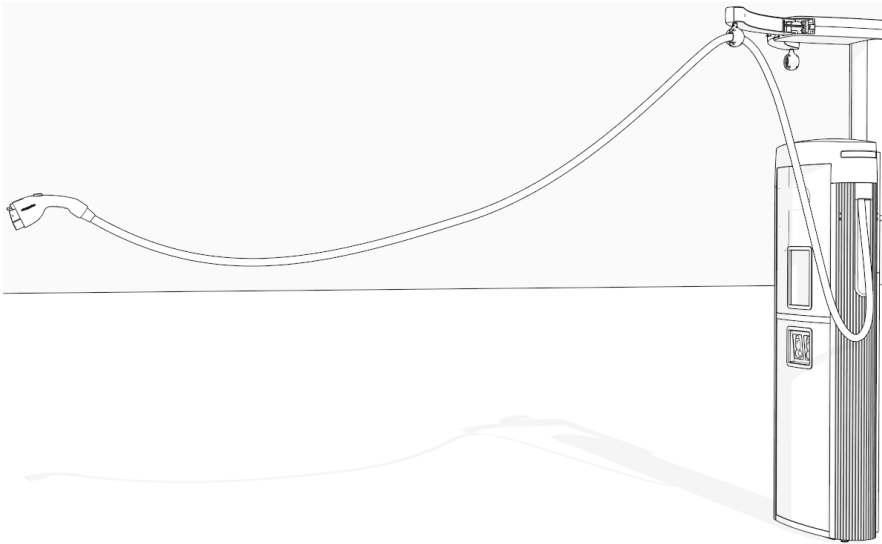

- Tall CMK tool balancer extension:

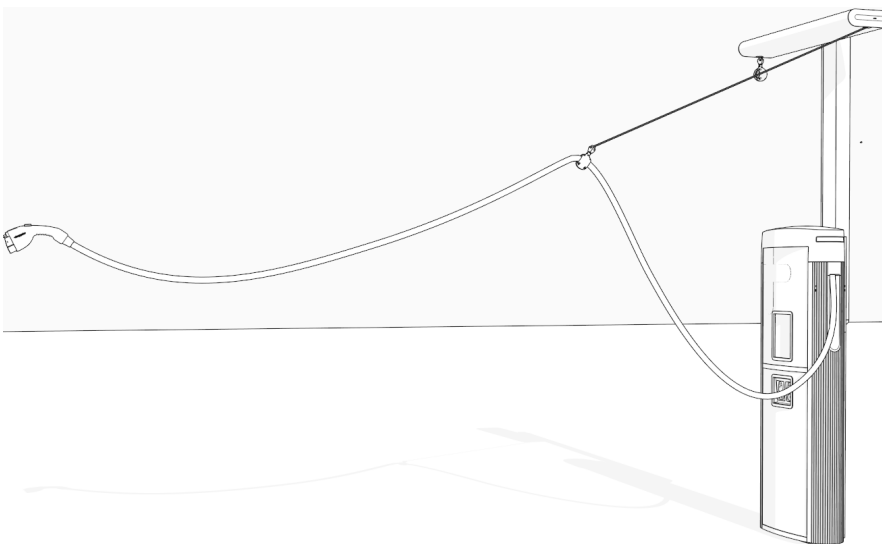

5. If two charging cables have been installed, repeat for the other side.

Install CMK Covers

To install CMK covers, complete the following steps:

1. Find the front and rear covers shipped in the CMK package.
2. Insert one edge of the rear cover into one of the grooves on the rear side of the CMK mast.

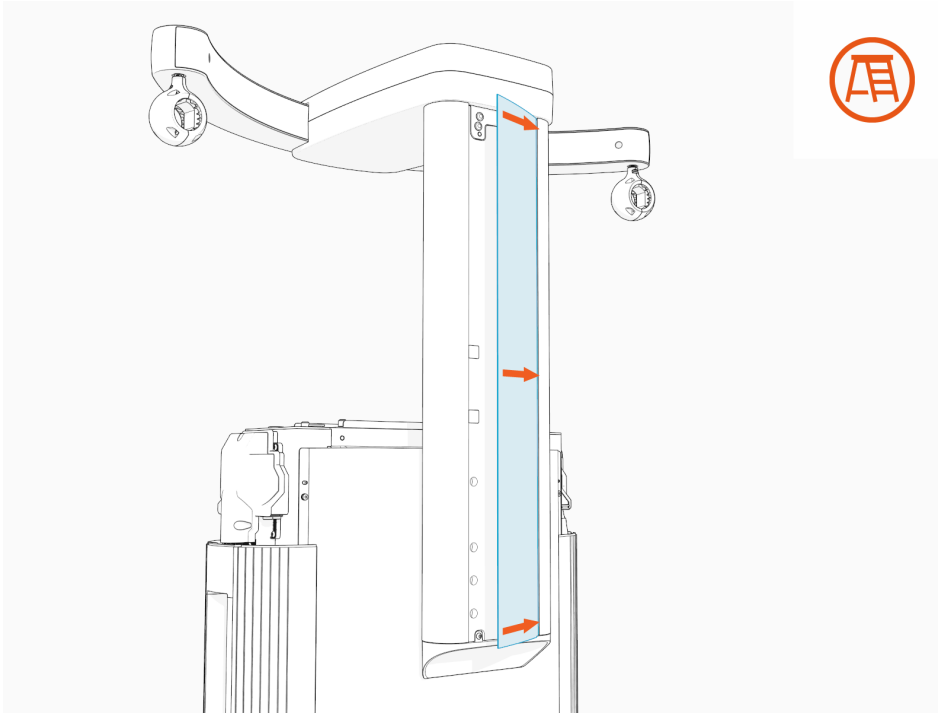

3. Gently flex the rear cover to insert its other edge into the other groove on the rear side of the CMK mast.

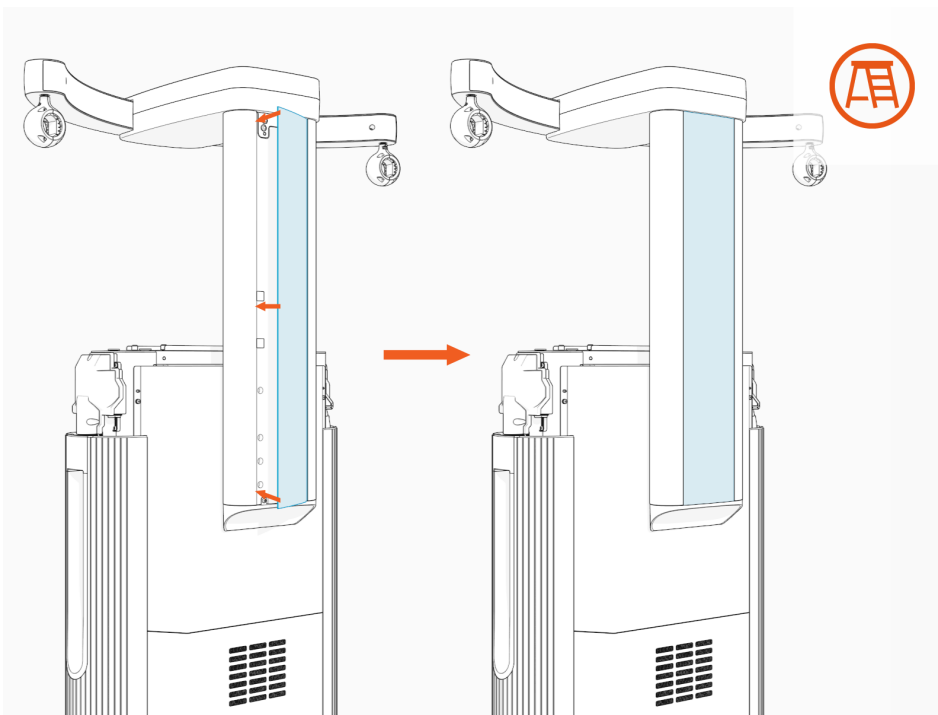

4. Repeat the above steps for the front cover and ensure the following:

- If installing covers on the standard CMK at maximum height, make sure that the front cover is resting on the two shoulder screws on the front side of the CMK mast.

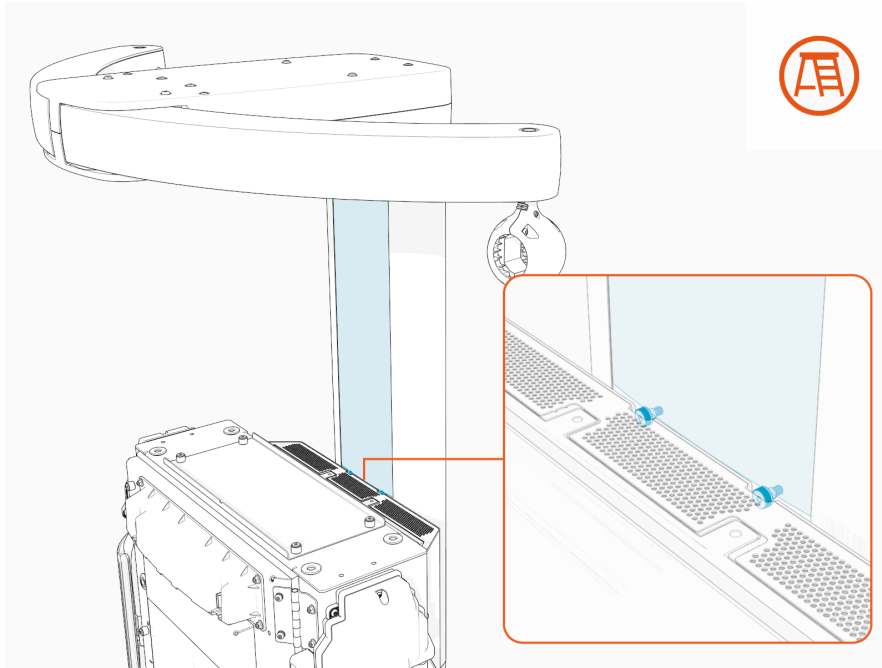

- If the CMK (either standard or tall) is installed at minimum height, cut its front cover to the following height:
 - a. Standard CMK's front cover:

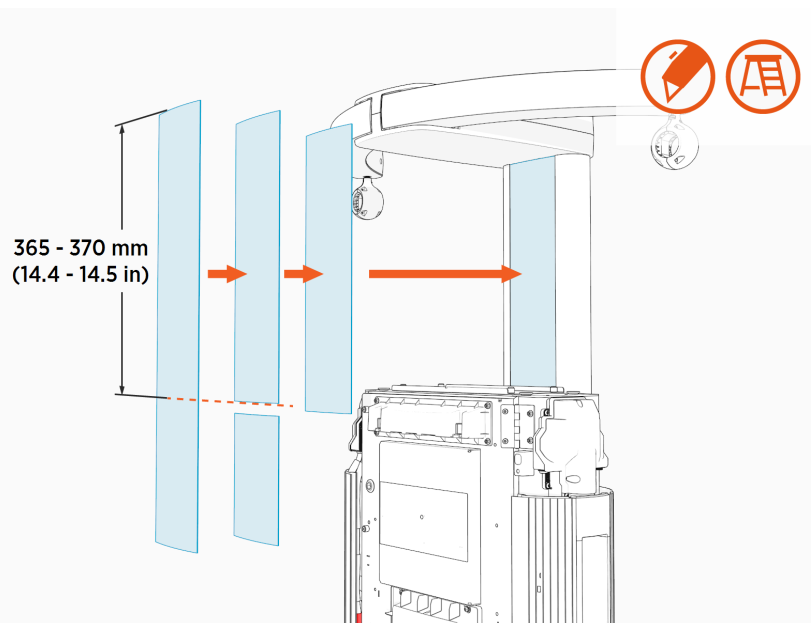

b. Tall CMK's front cover:

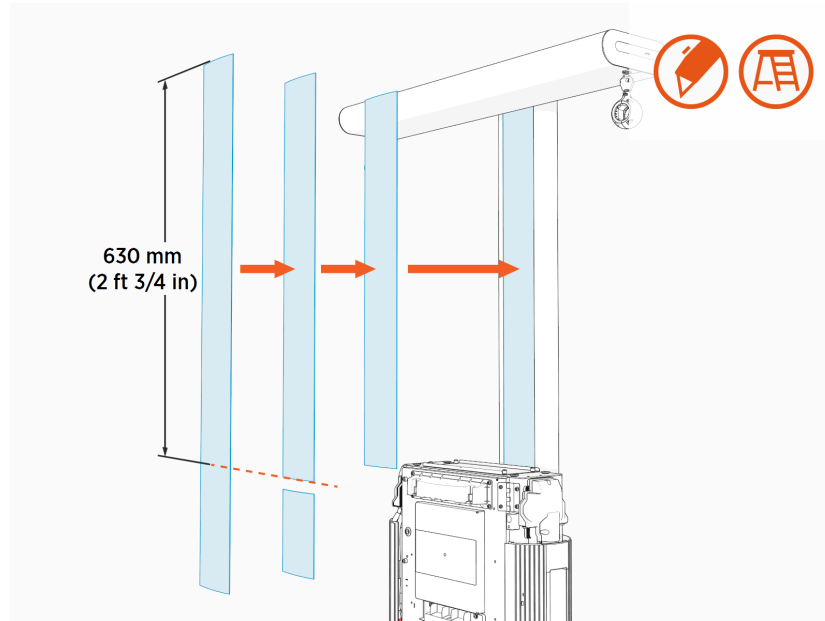

Close and Install Covers 7

To close the station and install covers, carry out the following steps:



IMPORTANT: Do not reconnect the power after completing the installation (after installing the covers). An Authorized Commissioning Partner will commission, power on, pinpoint, and configure Power Link 2000 after installation.

Seal Conduit Openings

To seal conduit openings, complete the following steps:

1. Find the duct seal compound shipped with the Power Link 2000 (see [Power Link 2000 Packages](#)).
2. Vacuum any residue around the conduits.

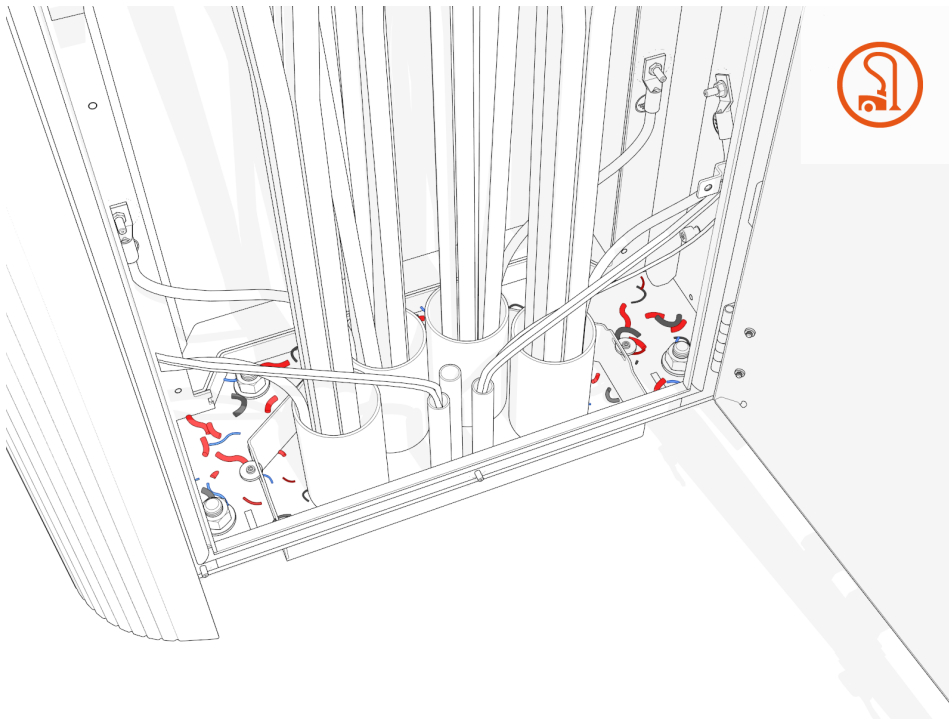

3. Torque the screws (x2) to **4.5 Nm (40 in-lb)**. The conduit sleeve must enclose the conduit opening space.

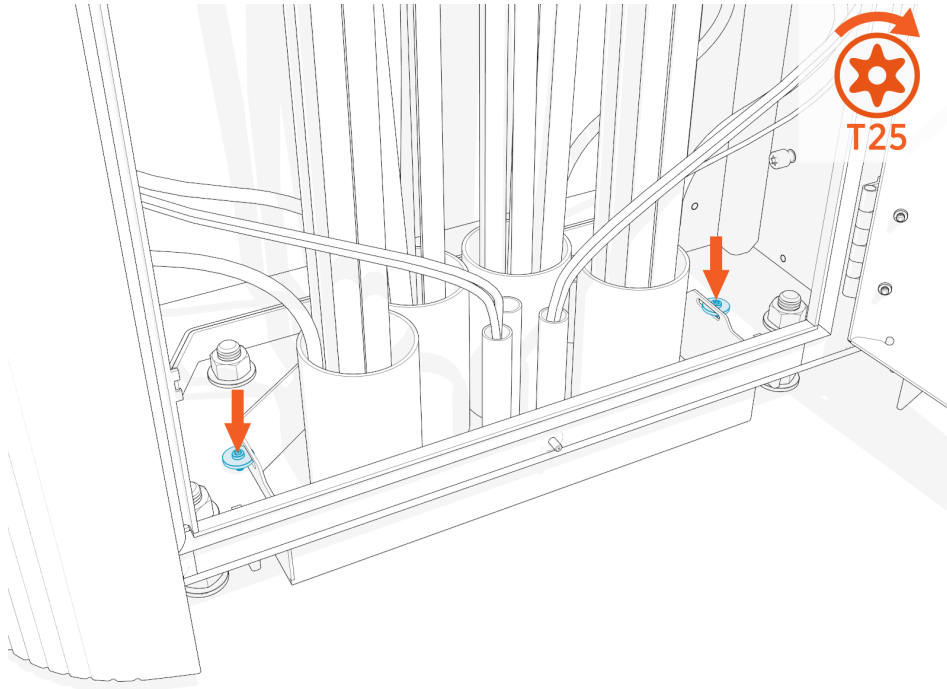

4. Use the duct seal compound and seal the space between the conduit sleeve and the bottom of the Power Link 2000 enclosure.

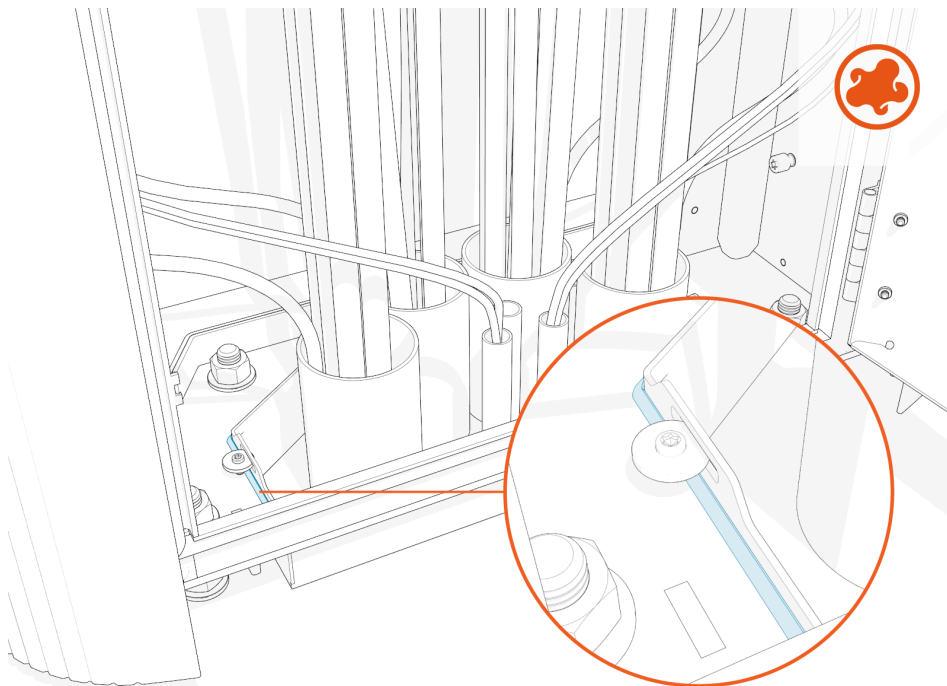

Reinstall Rear Upper Cover

To reinstall the rear upper cover, complete the following steps:



IMPORTANT: Skip this section if rear upper cover was not removed.

1. Align and seat cover onto the alignment pins (x2) on the frame.

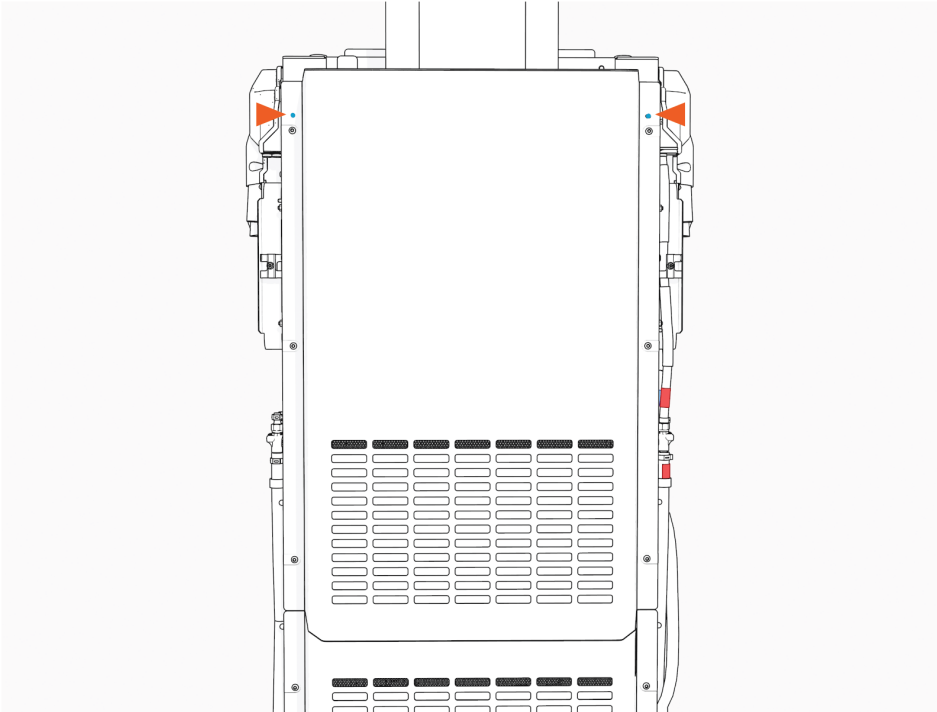

2. Torque the screws (x6) to **4.5 Nm (40 in-lb)**.



Reinstall Side Panels

To reinstall the side panels, complete the following steps:



IMPORTANT: Skip this section if side panels were not removed.

1. Hold the charging cable up and place it into the cable way on the side panel.

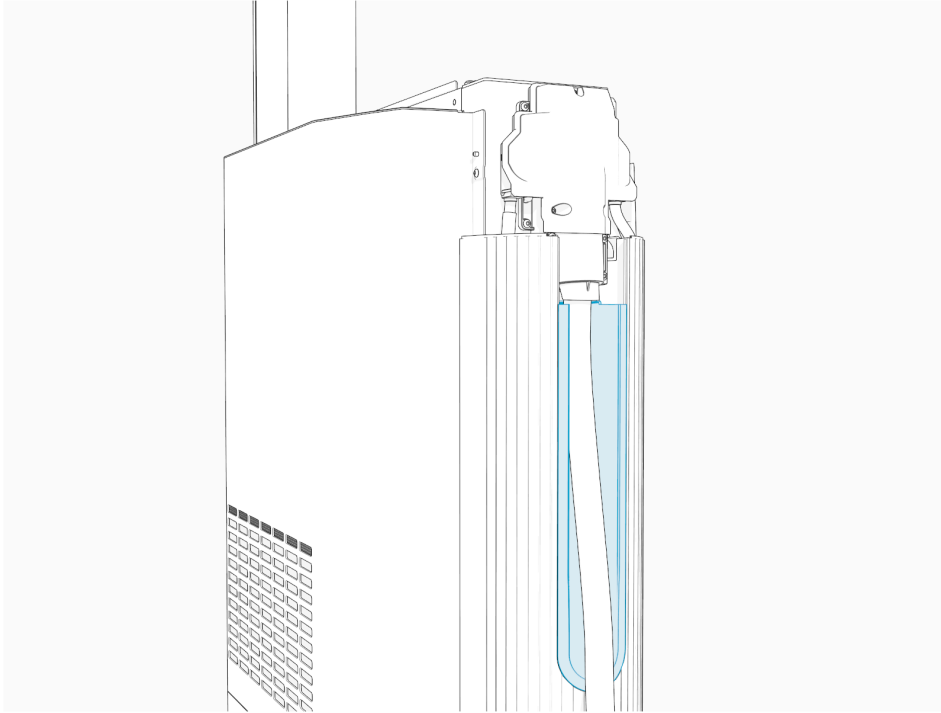

2. Align and install the side panel onto the hooks (x2) and alignment pins (x2) on the frame.

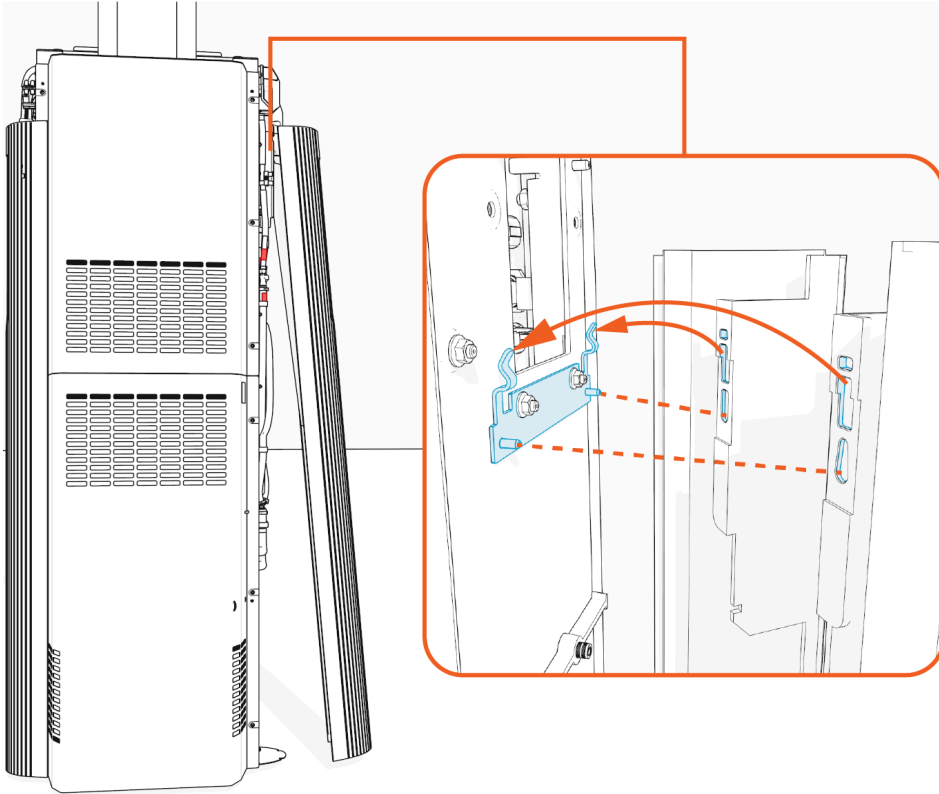

3. Slowly slide the side panel down to engage the hooks (x2) on the frame.

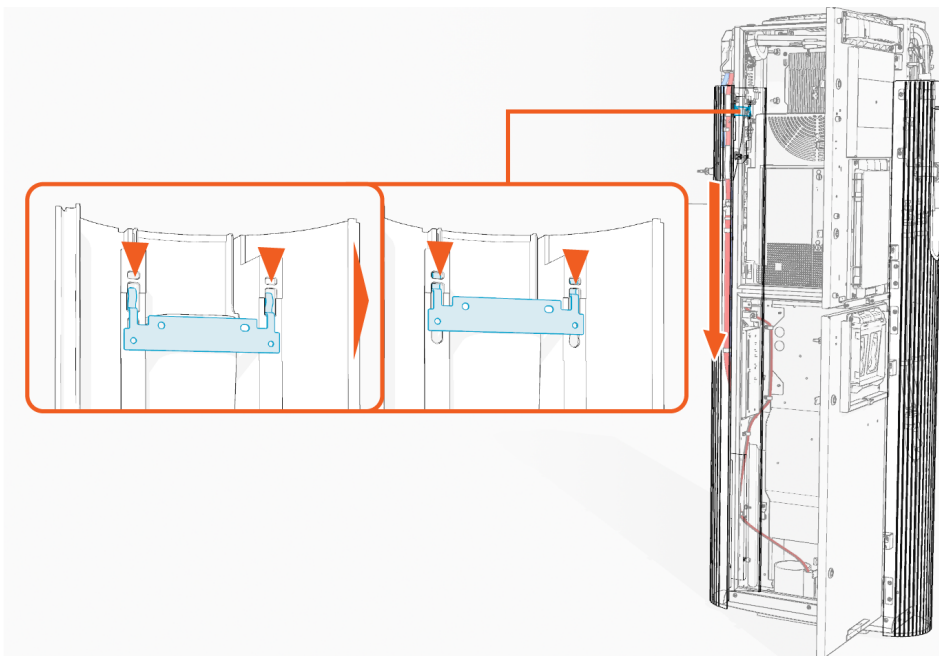

4. Align the screw holes (x2) on the rear side of the side panel with the screws (x2) inside the lower enclosure and torque them to **4.5 Nm (40 in-lb)**.

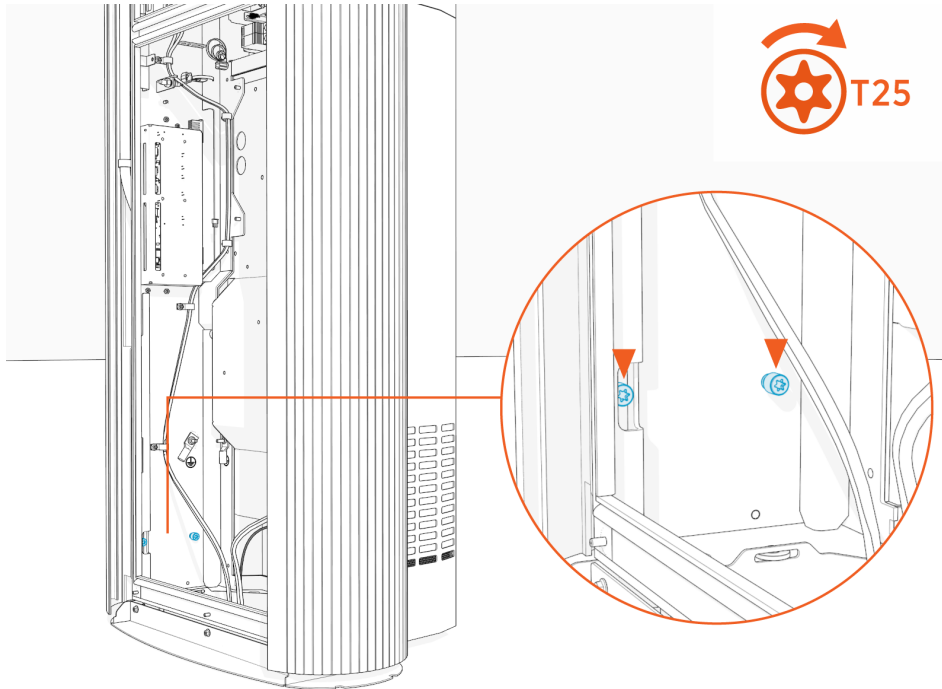

If two charging cables have been installed, repeat the procedure to install the other side panel.

Reinstall Cable Cap

To reinstall the cable cap, complete the following steps:

1. Align and slide the cable cap down to reinstall.

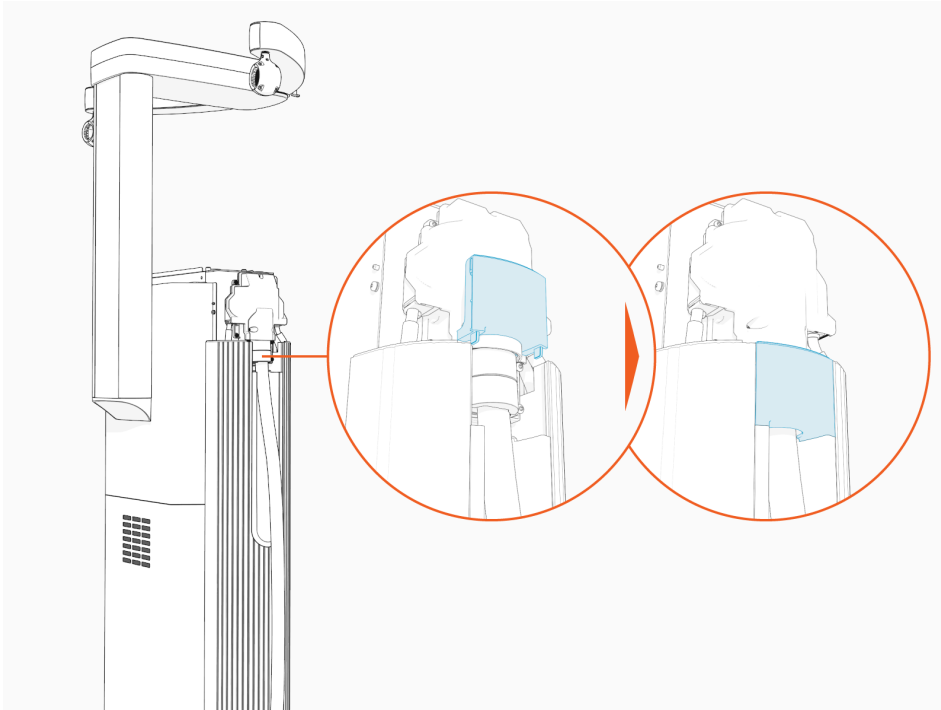

2. If two charging cables have been installed, repeat for the other side.

Reinstall DC Power Path Bus Bar Safety Cover

Install cover onto the hooks (x2) and brackets (x2) and then slide it down.

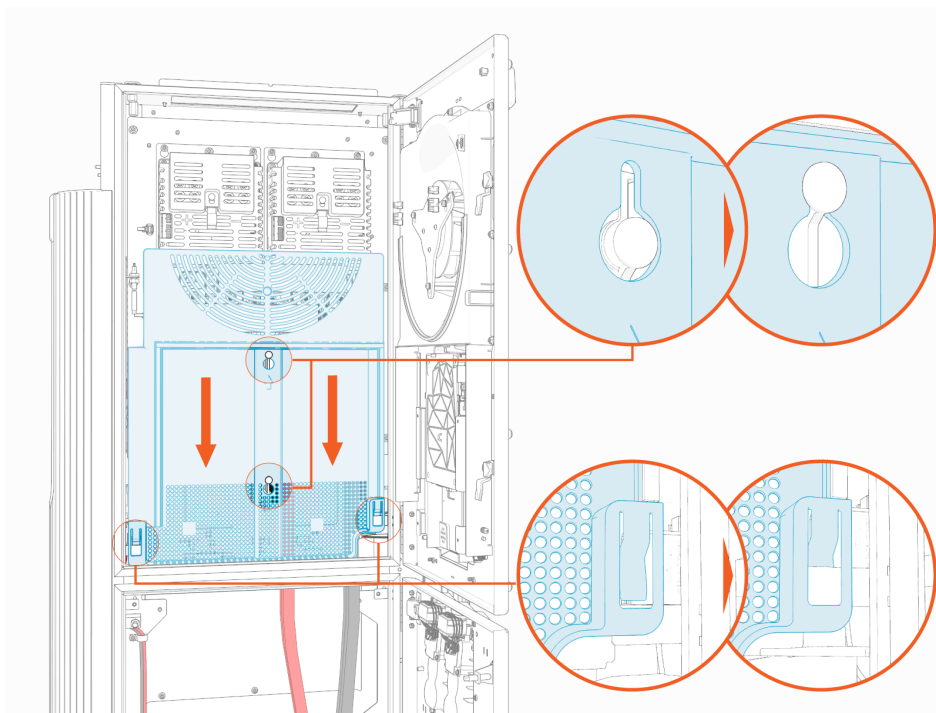

Record MAC Address

Take a photograph of the Power Link 2000 activation QR code and MAC address, which can be found on the label affixed to the top of the Control and Communications Module (CCOM). This information is used at Power Link 2000 setup.

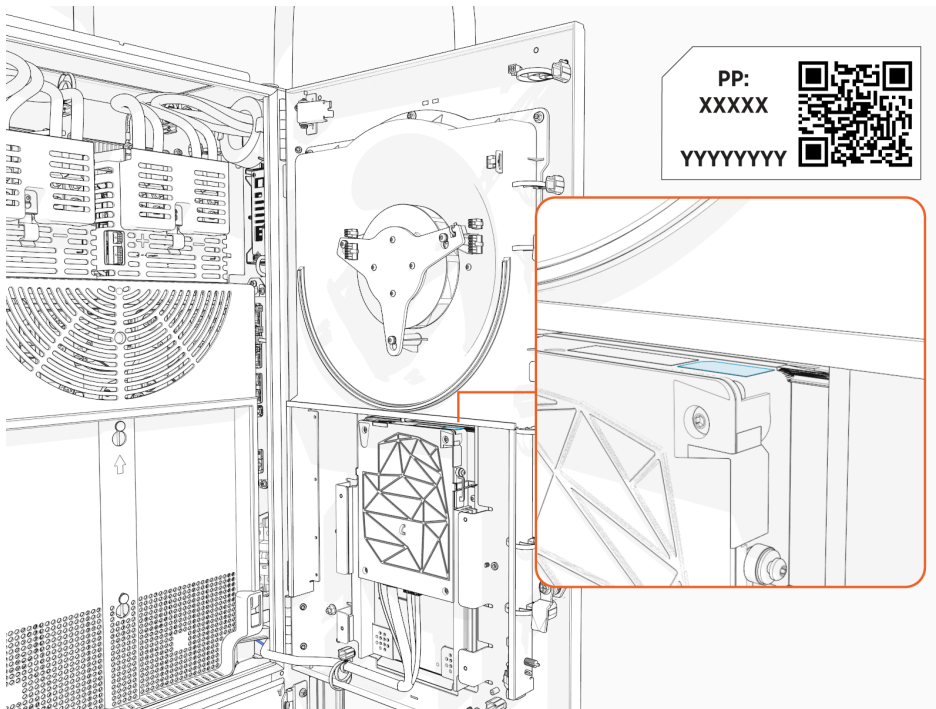

Close Enclosure Doors

To close enclosure doors, complete the following steps:

1. Disengage the door stopper (x1 per upper and lower enclosure door).

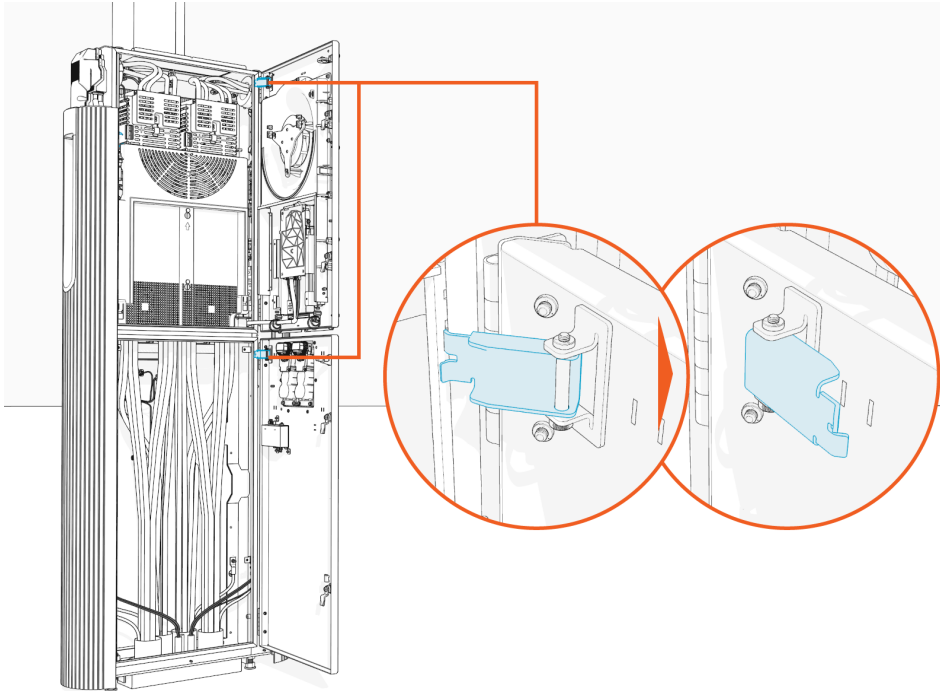

2. Quarter turn the door latches (x2 per upper and lower enclosure door).

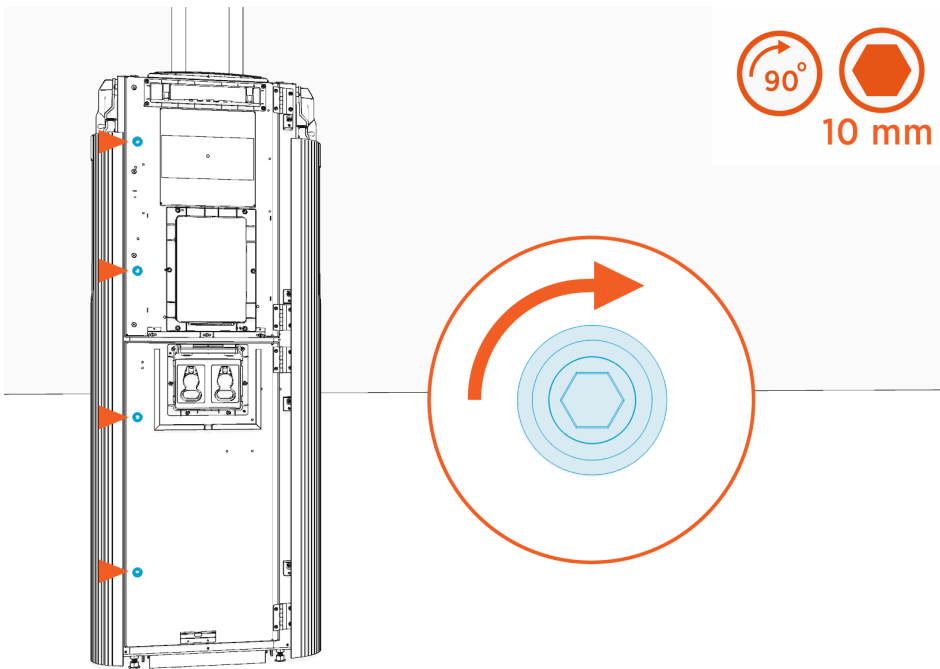

Install Front Upper Cover

To install the front upper cover, complete the following steps:

1. Insert any one side of the cover into the groove on the side panel.

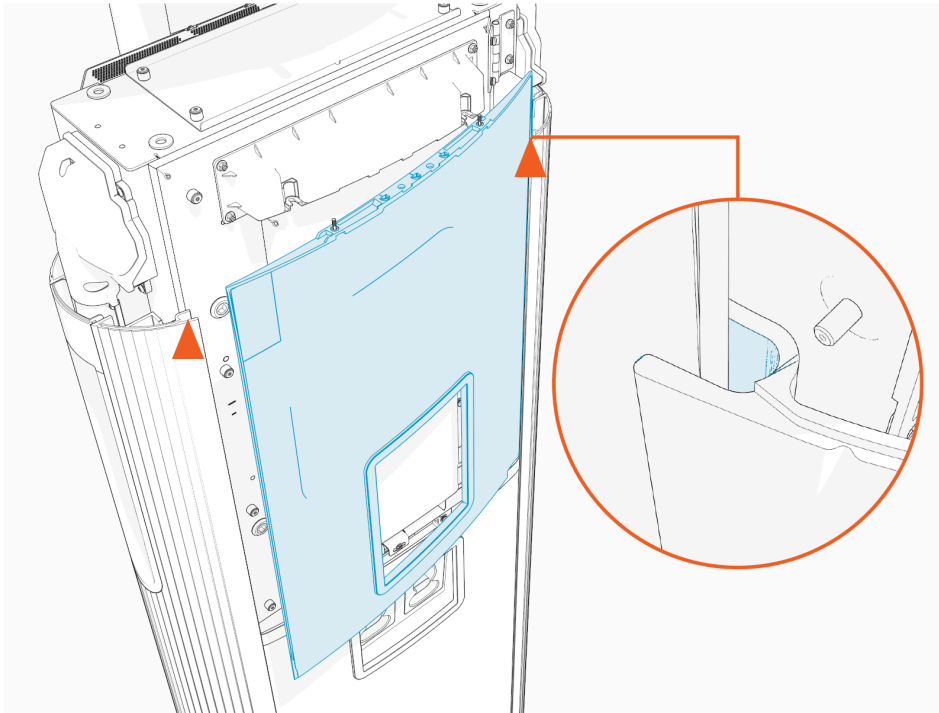

2. Gently flex the cover to insert its other side into the groove on the other side panel. At the same time, align and hook the ball studs (x3) behind the cover into the holes (x3) in a bracket on the upper door.

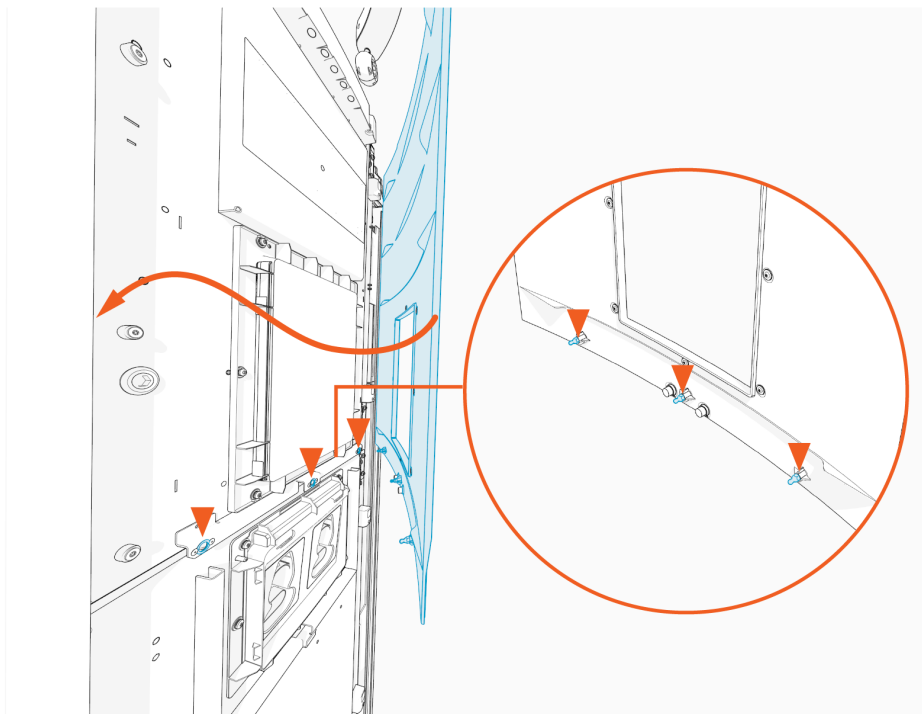

3. Alternatively, you can hold and flex the lower side of the cover slightly outward. While flexed, align the ball studs (x3) behind the cover with the holes (x3) in the bracket on the upper door and press in.

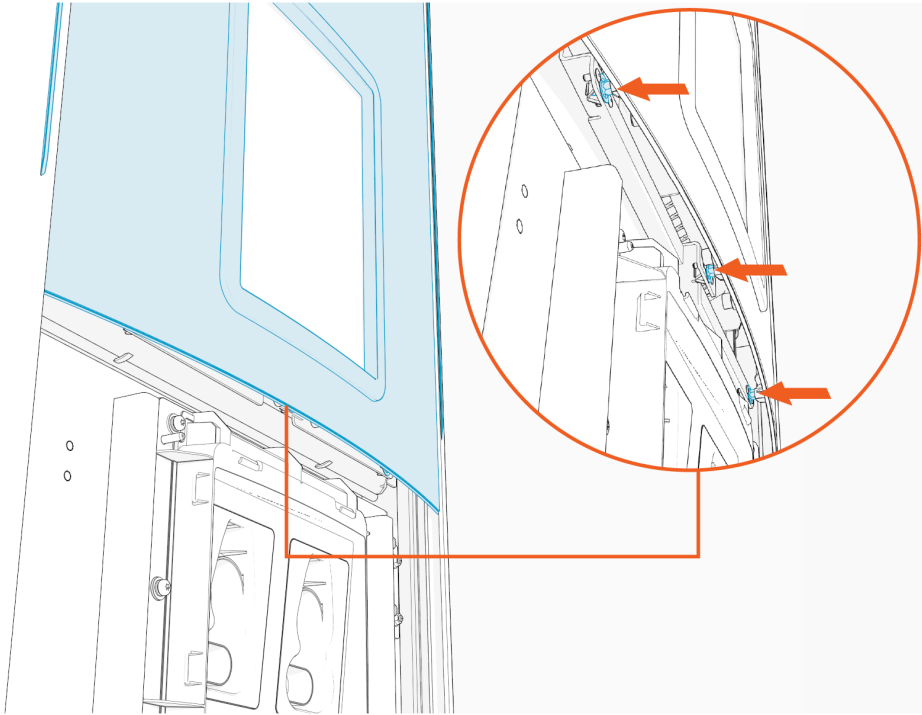

4. Make sure that the screws (x2) on the front upper cover are seated in their slots in the area light housing.

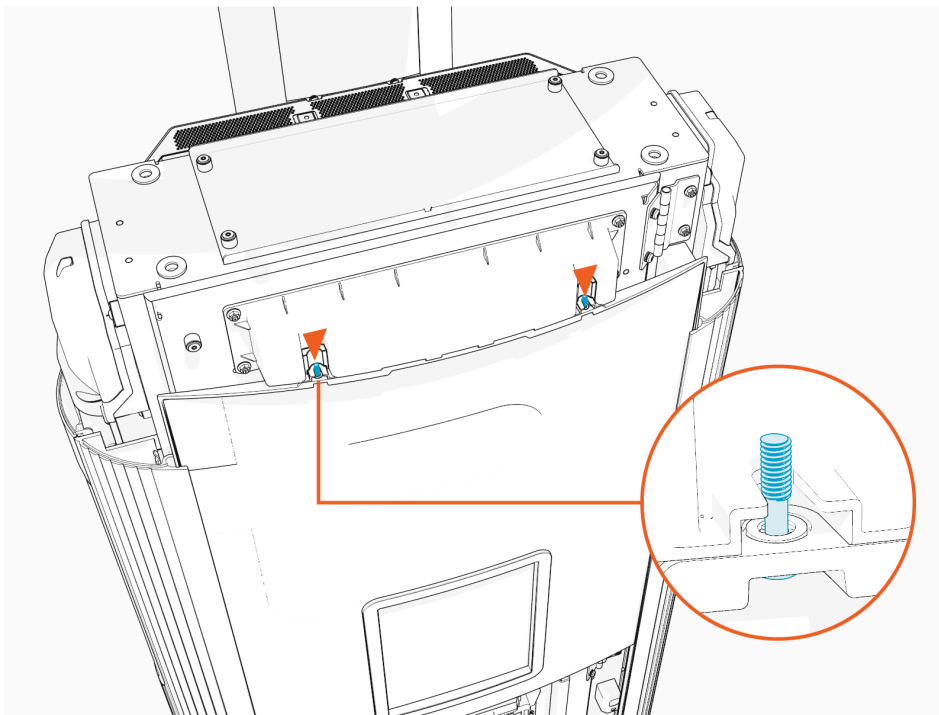

Install Front Lower Cover

To install front lower cover, complete the following steps:

1. Align top edge of the lower cover with the lower edge of the Control and Communication Module (CCOM) trim.

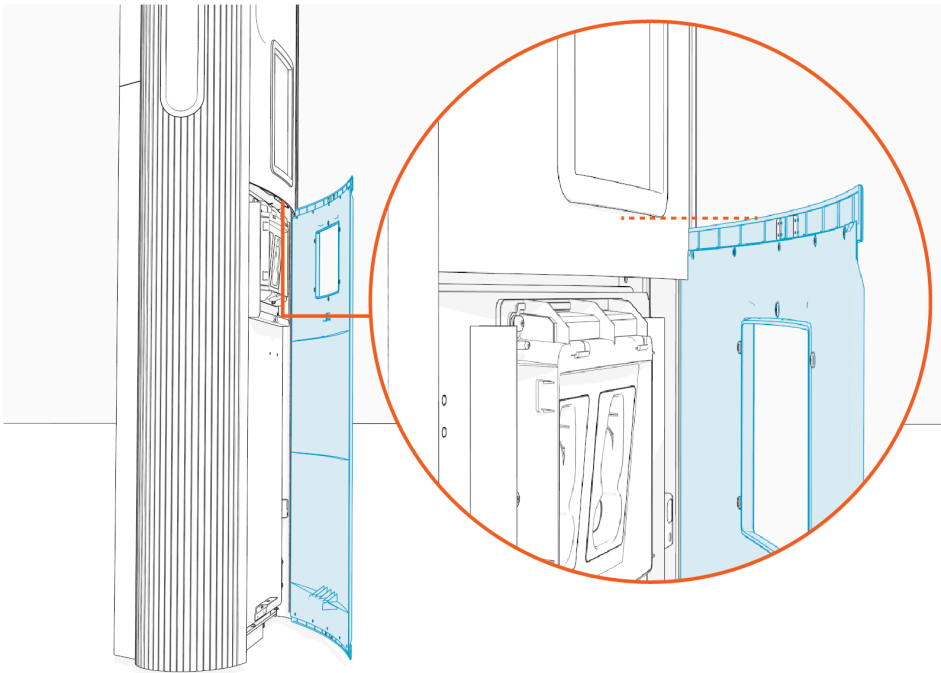

2. While overlapped with the upper cover, insert any one side of the cover into the groove on the side panel.

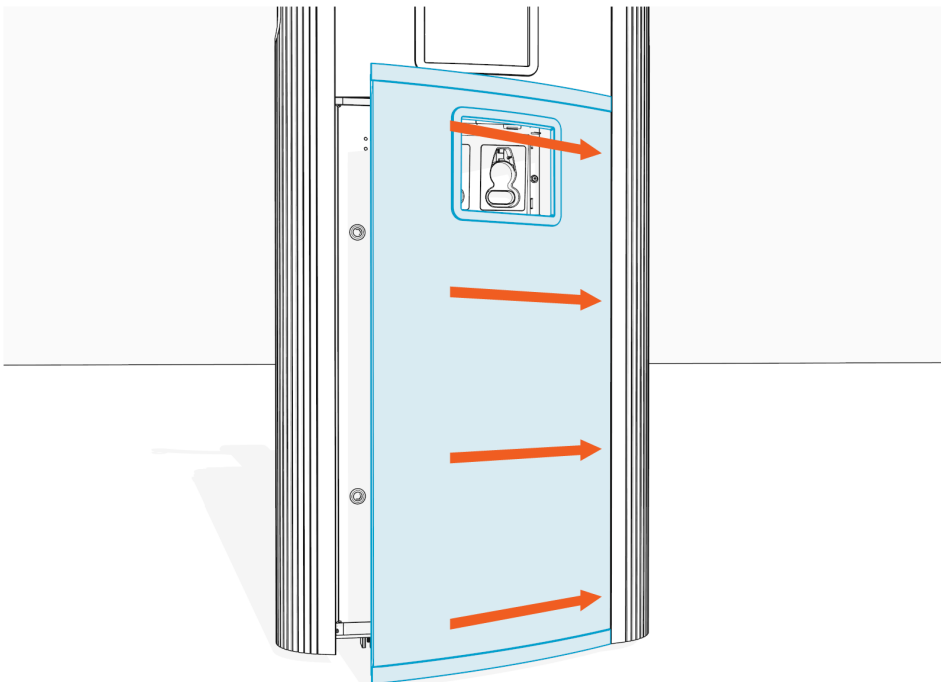

3. Gently flex the cover to insert its other side into the groove on the other side panel. Make sure that the top and bottom corners of the cover are seated in the groove.

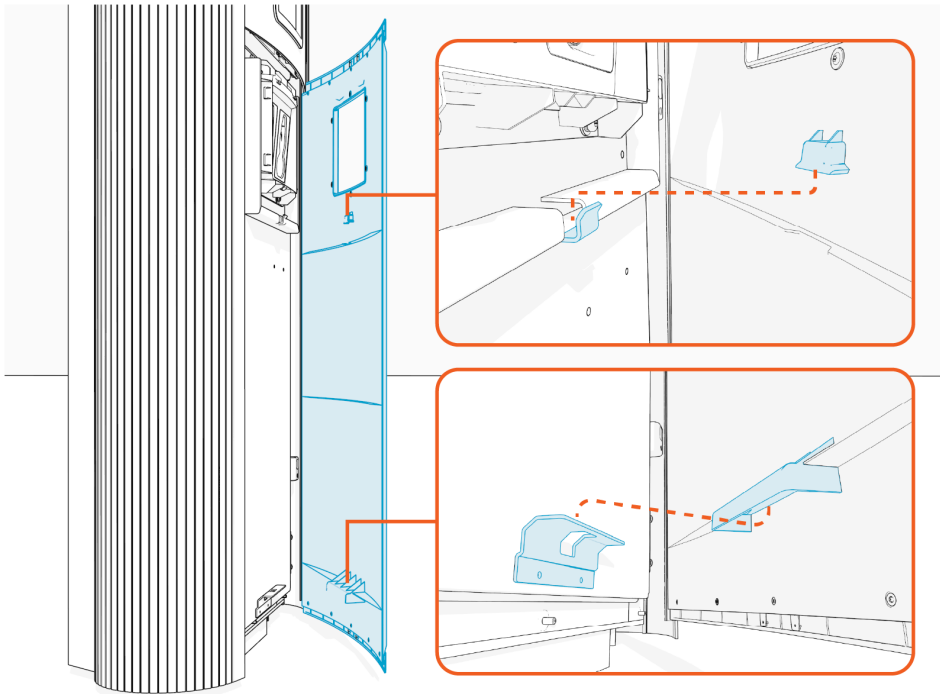

4. Press in below the holster trim and lower side of the cover; while pressed in, slide the cover down to engage the hooks (x2) behind the cover. See the previous step for the exact location of the hooks.

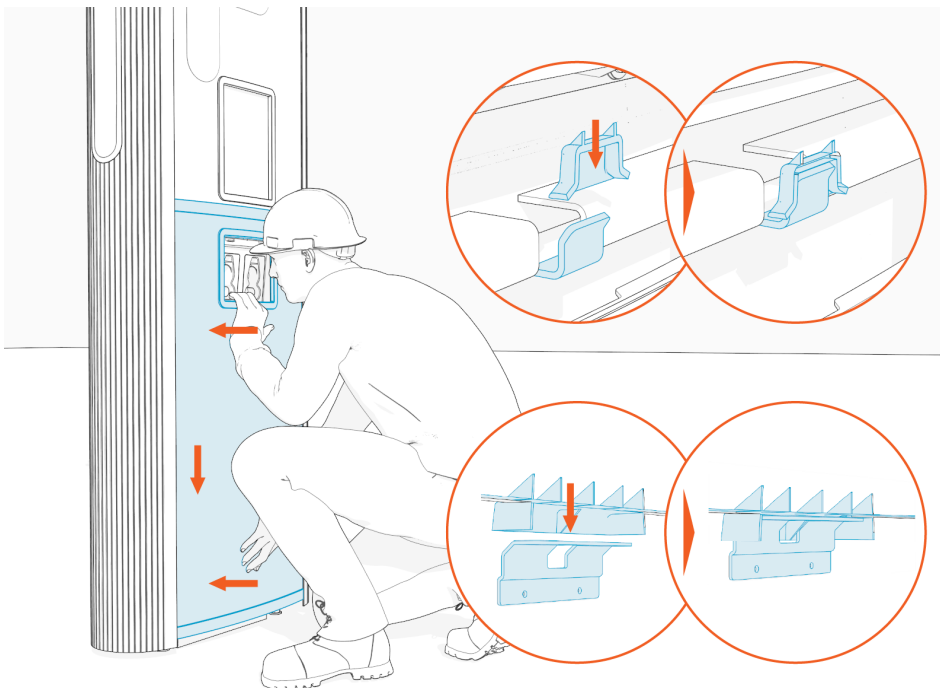

5. Make sure that the lower edge of the holster bracket and holster trim are aligned.

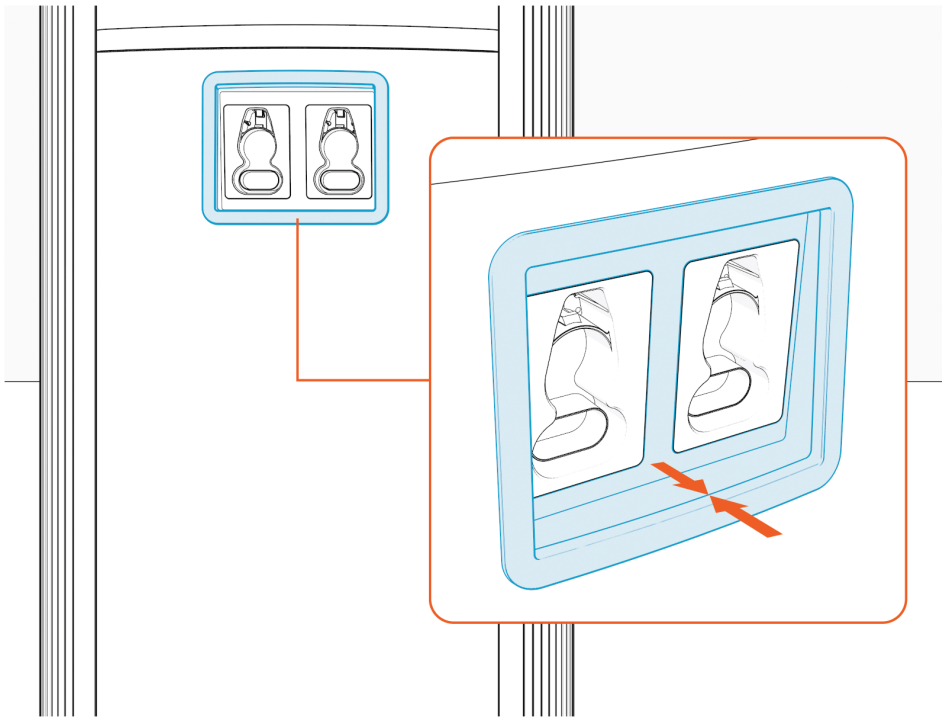

6. Place charging cable connectors into the holsters.

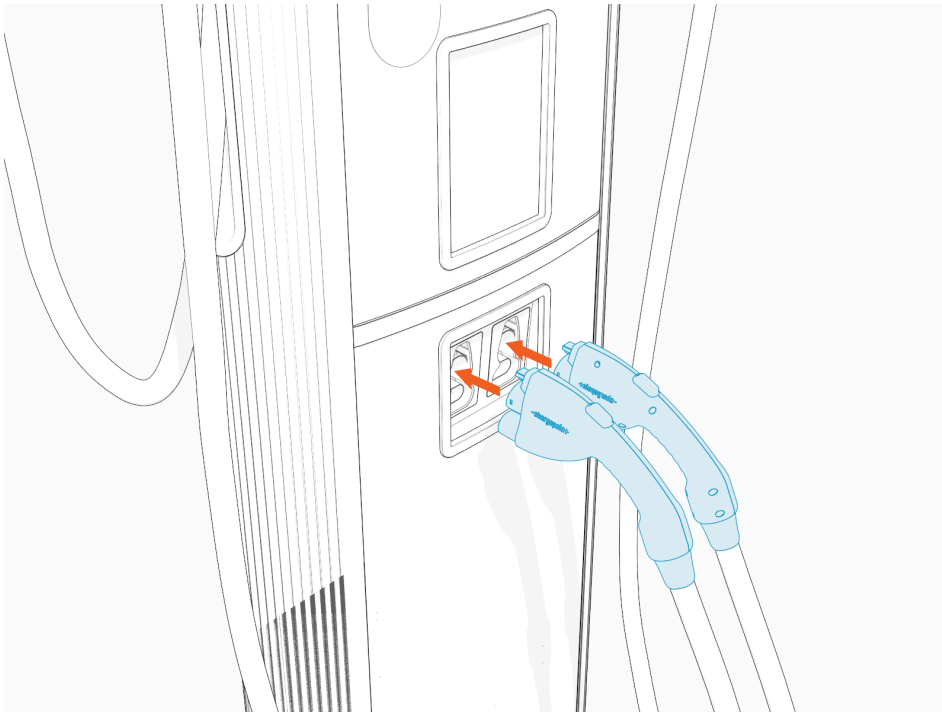

Install Top Cap

To install the top cap, complete the following steps:

1. Align the screws (x4) and install the top cap.

- Front screws (x2)

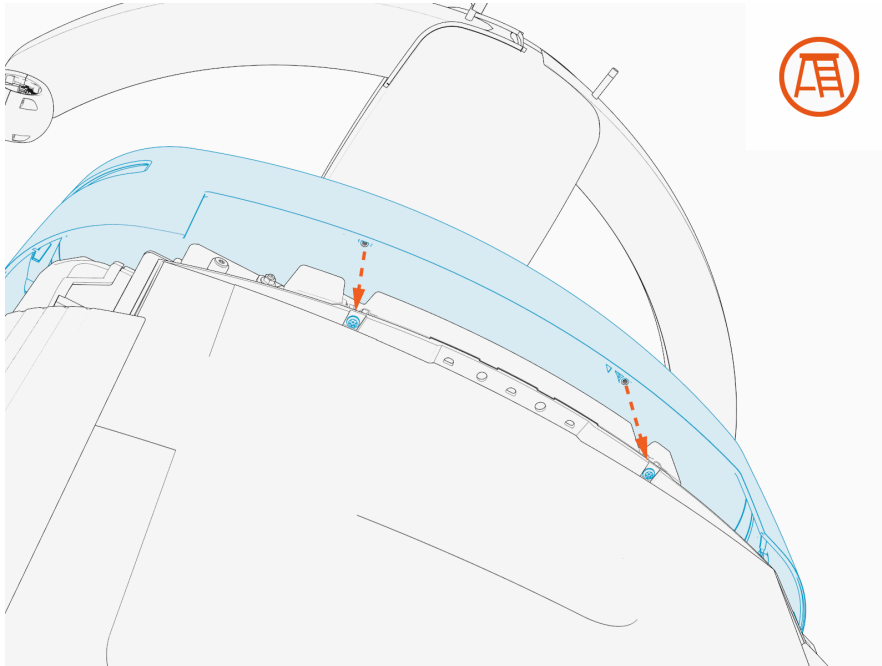

- Rear screws (x2)

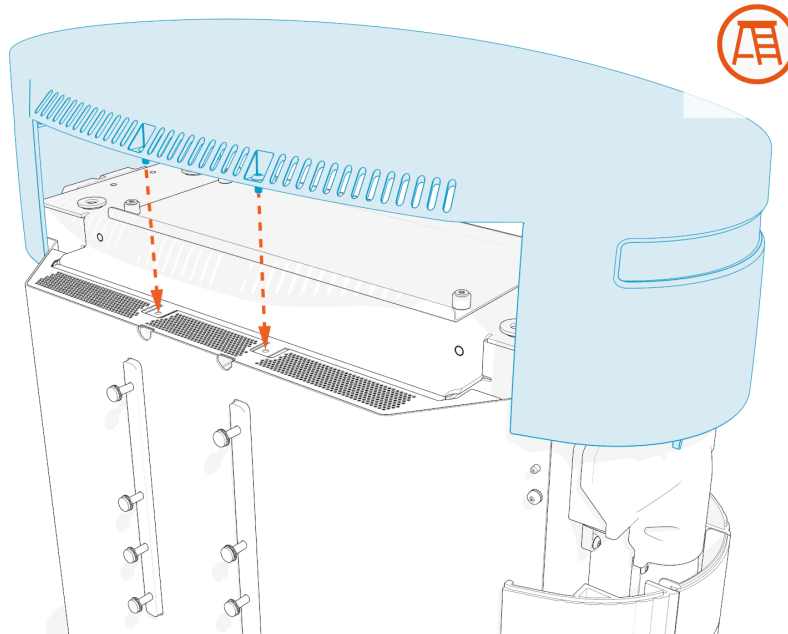

2. Make sure that the top cap sides are seated on edges on top of the side panels (x2).

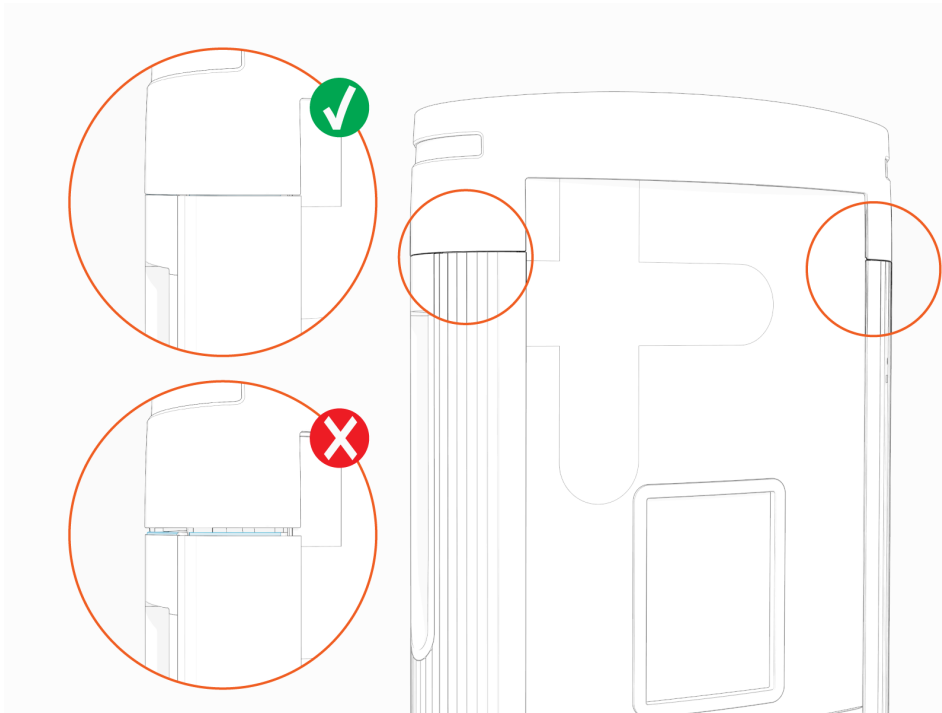

3. Torque the rear screws (x2) to **2.8 Nm (25 in-lb)** and front screws (x2) to **1.7 Nm (15 in-lb)**.

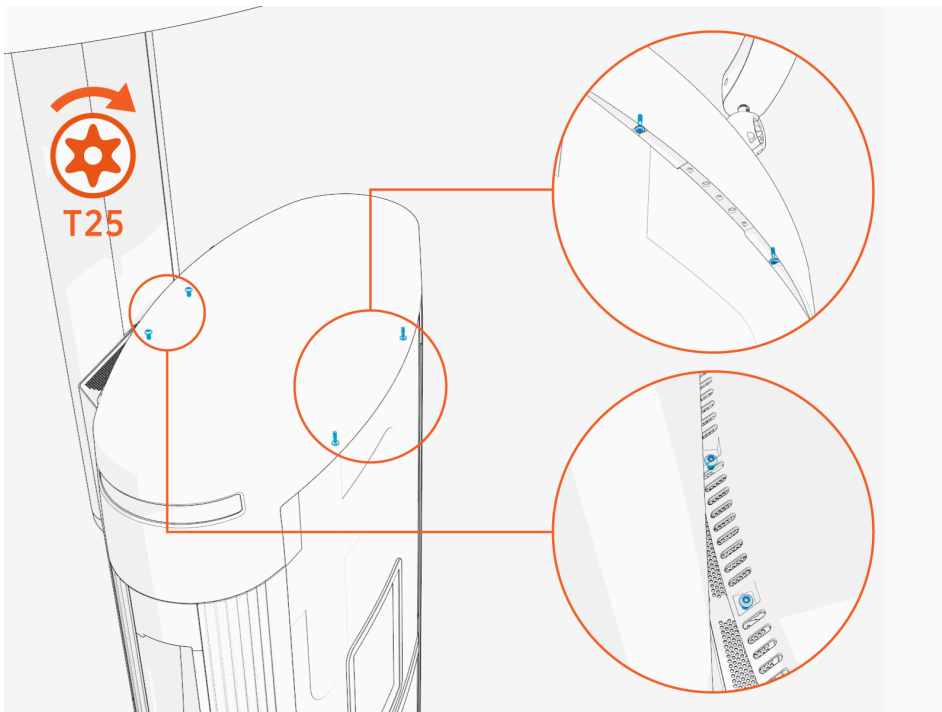

Complete Installation Checklist 8

To adhere to ChargePoint best practices, complete the [installation checklist](#) before leaving the installation site.

Provide the completed checklist and any spare parts (activation labels, and so on) to the person responsible for activating the stations. This completes the installation of the Power Link 2000 charging station.

Appendix: Surface Conduit Entry A Kit Installation

The Surface Conduit Entry (SCE) kit can be used at sites where the wires cannot be laid underground or when the site is not using stub-up entry through Concrete Mounting Template (CMT) embedded in a concrete pad.



NOTE: This SCE kit is only for the pedestal-mount variant of Power Link 2000.

Required Tools and Materials

In addition to the tools and materials required for installing Power Link 2000, the installer must bring the following tools and materials for the installation of SCE kit.

Tools



Power drill (with level feature recommended)



Sheet metal hole saw with pilot drill bit for conduit sizes listed on site drawings

Concrete drill bits

- 20 mm (13/16 in) or per epoxy manufacturer's recommendation for M16 (5/8 in) anchor bolts
- 6 mm (1/4 in) to drill pilot hole



24 mm hex socket or open ended wrench

750 ml of epoxy with bonding strength of 11.7 MPa minimum, compressive strength of 82.7 MPa minimum, and tensile strength of 49.3 MPa minimum, such as Hilti HIT-RE 500 V3 (normal cure time), Hilti HIT-HY 200-A (fast curing), or similar.



NOTE: Different epoxy types have different cure times at various temperatures. Check local temperatures for the site in advance to help choose an appropriate epoxy.

Materials

IMPORTANT:



- Refer to the site drawings for the actual quantity and size of conduits required for the site.
- Use LB conduit bodies to route wires into Power Link 2000 from rear left or rear right.
- Use suitable conduit fittings to secure and seal the conduits and/or conduit bodies.

Refer to the *Express Distro Power Link 2000 Site Design Guide* for the maximum quantity and size of conduits that can be installed on Power Link 2000 using the SCE kit.

Kit Components

SCE Kit For LCC Power Link 2000

Check the package for the following components:



NOTE: For any missing component, contact ChargePoint support at chargepoint.com/support.

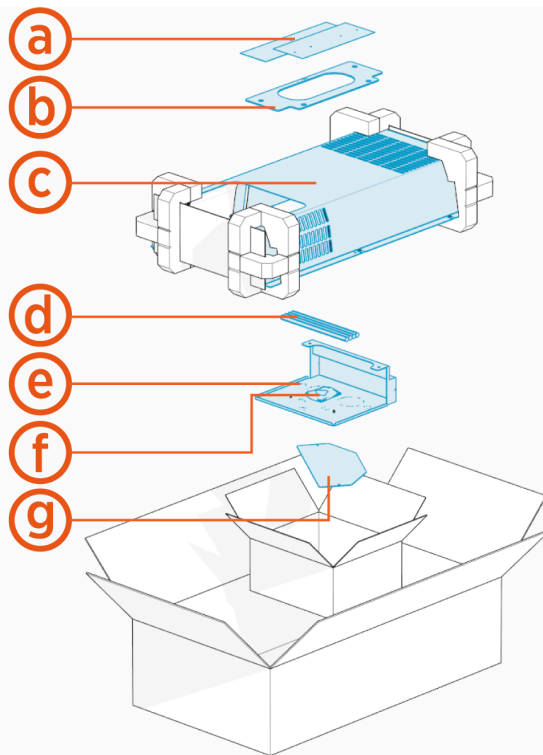

(a) Templates for marking and drilling conduit holes.

(b) Surface mount template for marking and drilling holes into concrete surface.

- (c) Rear lower cover replacement for SCE.
- (d) M16 anchor bolts (x4) for mounting Power Link 2000.
- (e) Mounting bracket for conduits.
- (f) Hardware bag, which contains the following components:
 - M16 nuts, washers, and protective caps for anchor bolts (d).
 - M5 nuts (x4) for mounting bracket (e).
 - M5 screws (x2) for gland plate (g).
- (g) Gland plate for closing the conduit opening.



NOTE: The SCE kit for LCC also contains the nameplate plate to affix to the SCE rear lower cover (c).

SCE Kit For non-LCC Power Link 2000

Check the package for the following components:



NOTE: For any missing component, contact ChargePoint support at chargepoint.com/support.

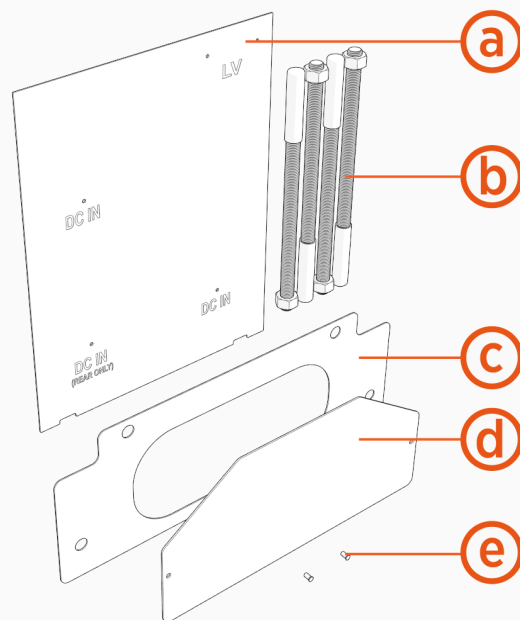

- (a) Template for marking and drilling conduit holes.
- (b) M16 anchor bolts and nuts with protective caps (x4) for mounting Power Link 2000.
- (c) Surface mount template for marking and drilling holes into concrete surface.
- (d) Gland plate for closing the conduit opening.
- (e) M5 screws (x2) to install gland plate.

Install Anchor Bolts

To install anchor bolts, complete the following steps:

1. Refer to the site drawings and place surface mount template at the proposed location.



NOTE: Make sure to leave enough clearance at the rear side (610 mm or 2 ft) for surface conduit entry and servicing.

2. Use a marker to mark the locations for the anchor bolts and remove the surface mount template.

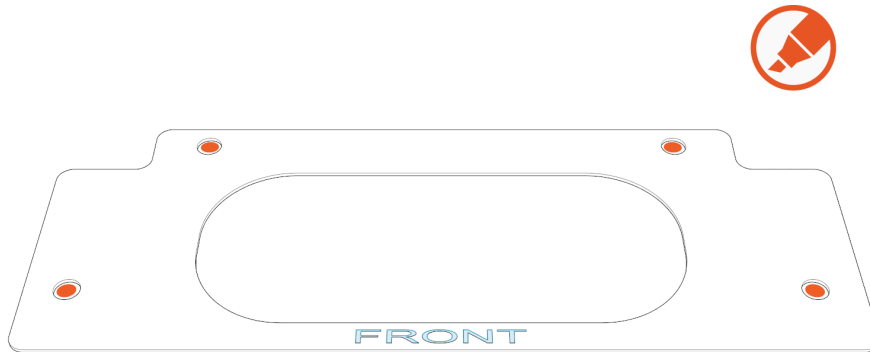

3. Use the 6 mm (0.25 in) concrete drill bit to drill a pilot hole about 51 mm (2 in) deep at each marked location. The holes must be parallel to each other and perpendicular to the surface.
4. Use the 25 mm (1 in) concrete drill bit to drill an anchor hole a minimum of 229 mm (9 in) deep. Anchor bolts must have 76 mm +/- 12.7 mm (3 in +/- 0.5 in) above surface.



5. Use a vacuum to clean the concrete residue.



6. Place surface mount template on the surface again. Verify that the anchor holes align with the holes in the surface mount template.
7. Prepare the epoxy. Ensure the applicator is dispensing correctly mixed epoxy before beginning work (for example, the Hilti epoxy is white when unmixed and gray when mixed).
8. Fill the first anchor hole with epoxy until the epoxy is about 44.5 mm (1.75 in) from the top of the hole.



IMPORTANT: Continue immediately to the next step because the epoxy sets within about eight minutes.



9. Insert anchor bolt into the hole. Rotate the anchor bolt as you insert it to draw epoxy into the threads. If needed, add more epoxy until it fills hole to surface level. Use paper towels to wipe off any excess.

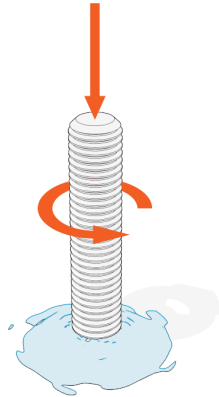

10. Use a level to check that the anchor bolt is plumb. If needed, adjust it while the epoxy is still setting.

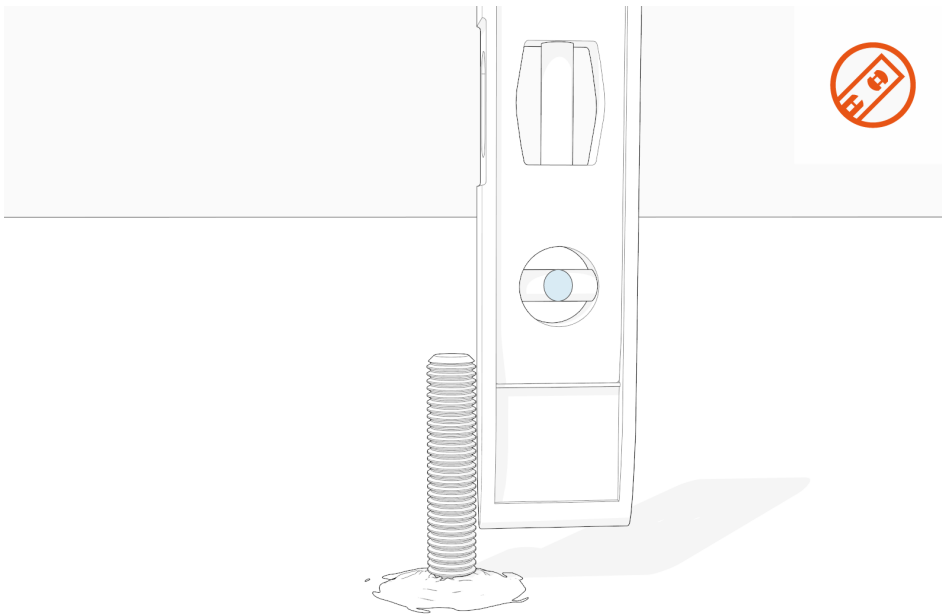

11. Measure the bolt exposed above the surface and it must be 76 mm (3 in).

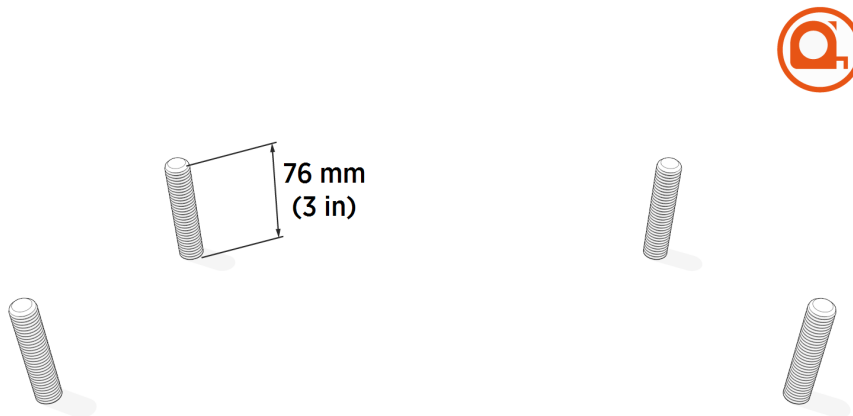

12. Repeat the above epoxy steps for each of the other three anchor bolts.
13. If Power Link 2000 station will not be immediately installed, insert protective caps over the anchor bolts.



14. Allow the epoxy to cure for the initial cure time listed on the epoxy usage instructions before beginning to install Power Link 2000.
15. Install Power Link 2000 onto the anchor bolts (see [Install Power Link 2000](#)).

Install Gland Plate

To install gland plate, complete the following steps:



IMPORTANT: Install gland plate to seal the conduit opening in Power Link 2000's bottom and prevent rodent ingress. If the [SCE kit](#) you received doesn't have a gland plate, apply the duct seal compound supplied in the Power Link 2000 package to fill the conduit opening. Make sure that it is fully sealed.

1. Find the M5 screws (x2) shipped in the SCE kit package.
2. Remove screws (x2) to remove the conduit sleeve.

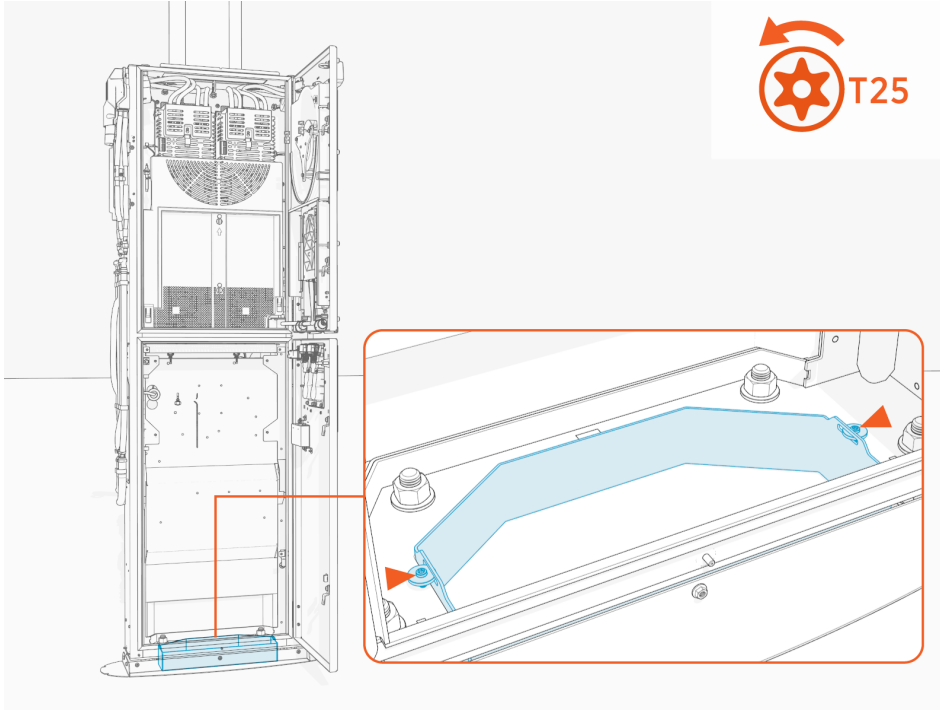

3. Install the gland plate using the M5 screws (x2) and torque the screws to **4.5 Nm (40 in-lb)**.

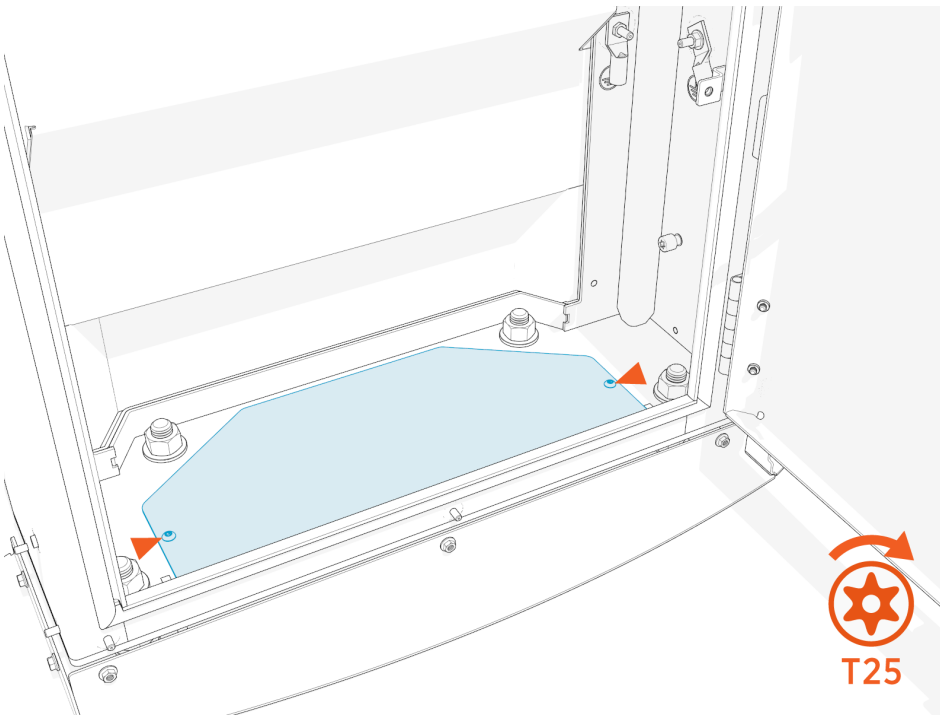

Install Surface Conduits (LCC)

Skip this entire procedure for non-LCC variant of Power Link 2000.

Before you Begin



IMPORTANT: Refer to the site drawings and determine from which side of the Power Link 2000 the wires must enter from.

1. If not already removed, remove the following:
 - a. Cable cap
 - b. Side panels
 - c. Rear upper cover
 - d. Loosen screws (x6) to remove the rear lower cover.

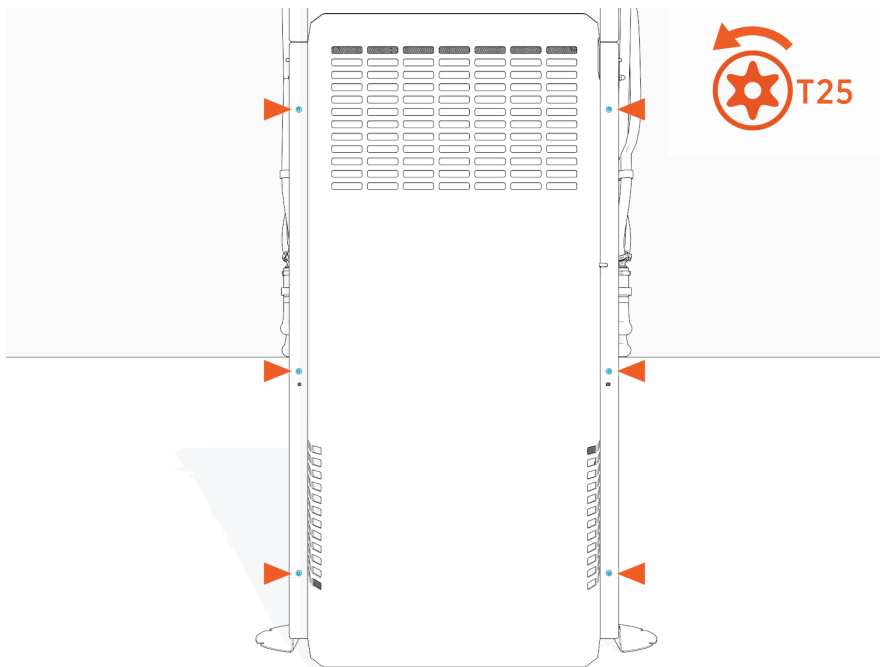

2. Open lower enclosure door.
3. Install gland plate.

Install Conduits

To install conduits, complete the following steps:

1. Align and hold templates against the lower enclosure wall.

IMPORTANT:



- Ensure that the templates are fully laid on the lower enclosure wall and that their edges are in alignment with the upper and side corners.
- The pilot holes marked DC IN are for cutting conduit holes for DC power path wires, and the ones marked LV are for 48 V DC wires and Ethernet cable.

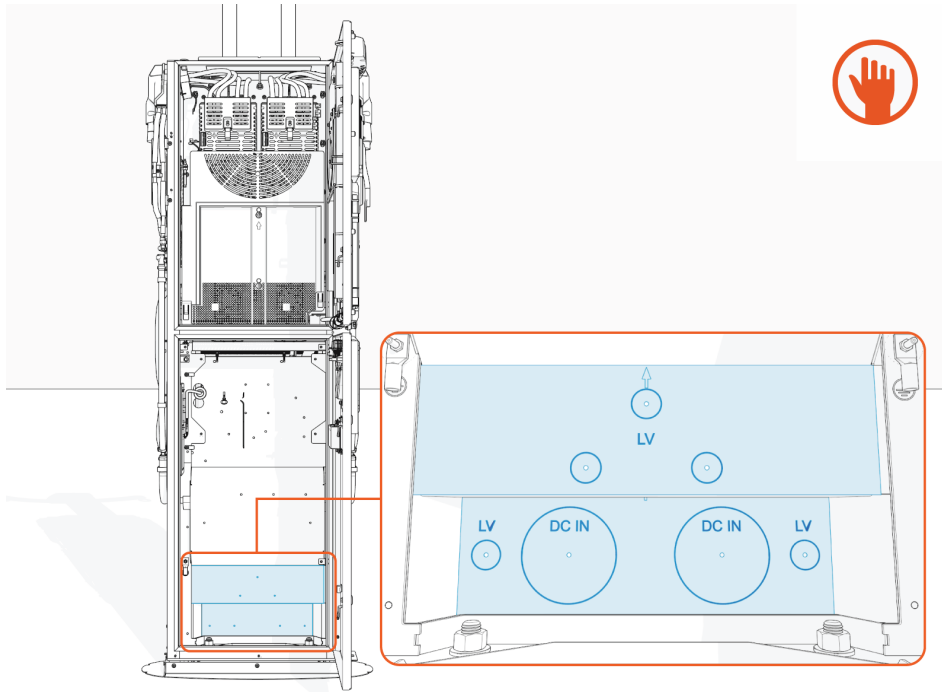

2. Mark pilot hole locations on the lower enclosure wall and remove the templates.

- If wires need to enter from rear left or right side of the Power Link 2000, mark LV holes on the upper template.

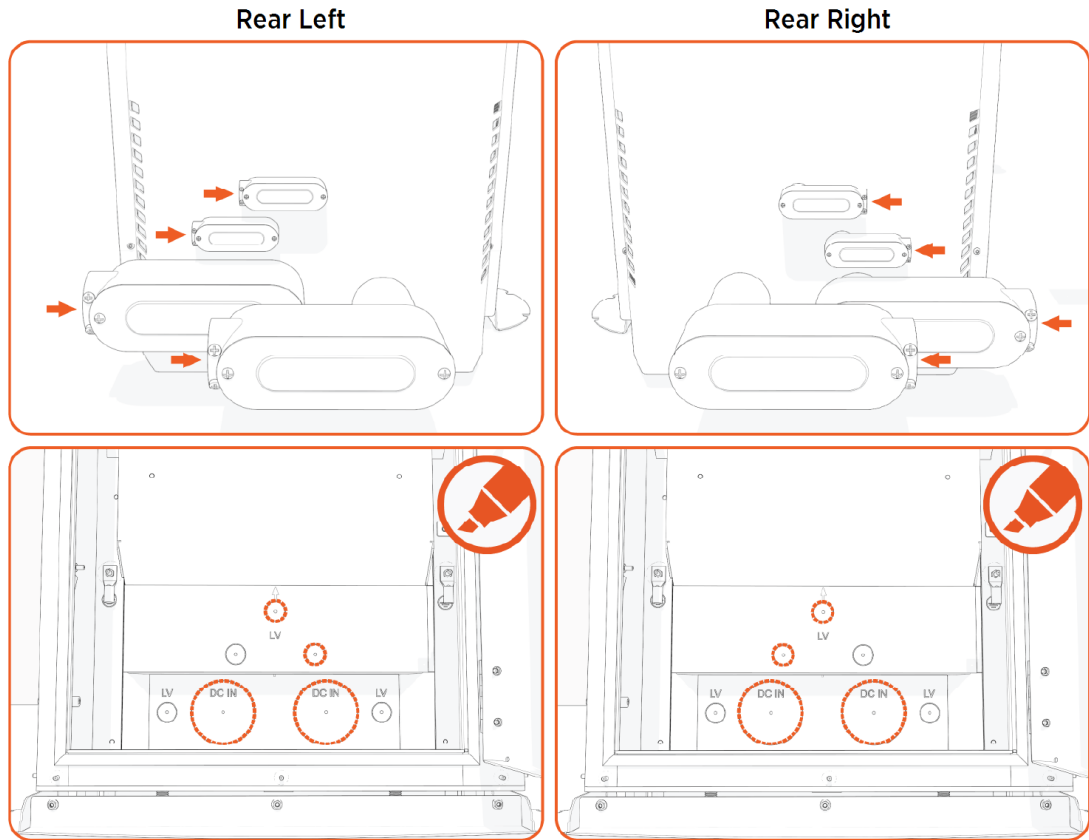

- If the wires need to enter the rear of the Power Link 2000 from straight on or from above the entry point, mark LV holes on the lower template.

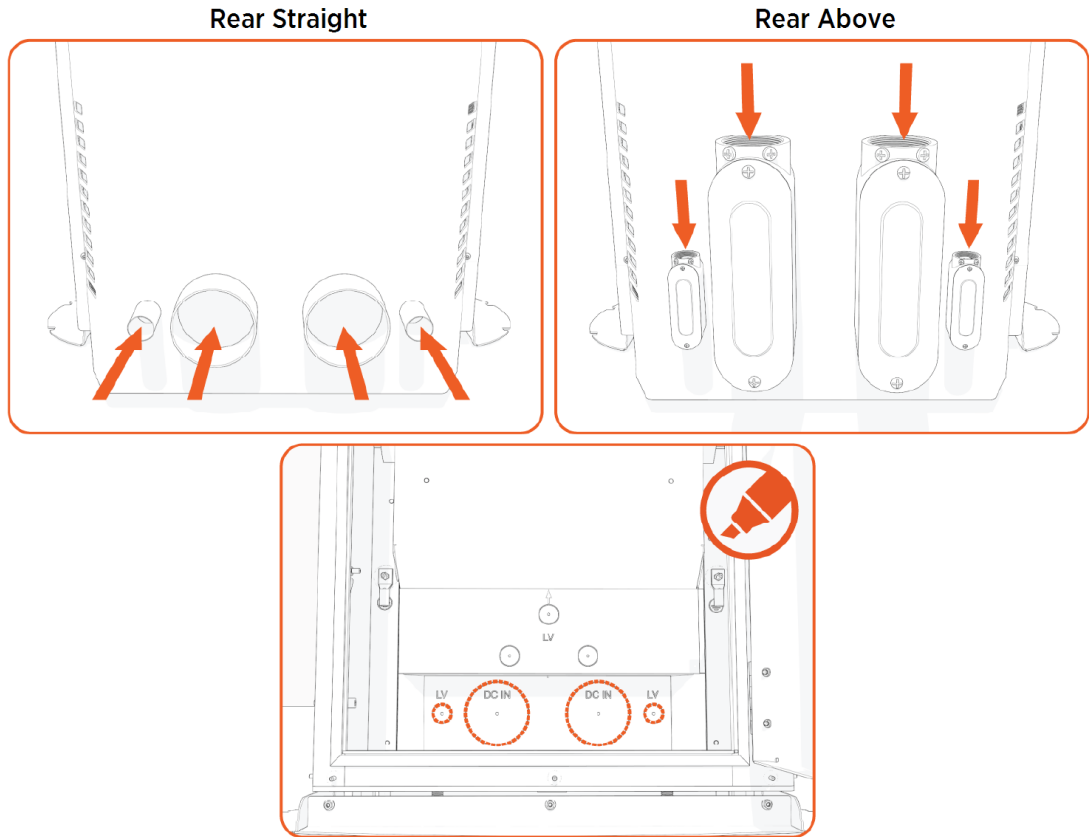

- Using a suitable hole saw, position the hole saw's pilot drill bit on the marked location, and cut a hole into the lower enclosure wall. Repeat for other marked locations.



IMPORTANT: To cut holes to correct size, refer to the site drawings for the actual conduit dimensions. For the maximum conduit size supported by the Power Link 2000, refer to the *Express Distro Power Link 2000 Site Design Guide*, available at [ChargePoint Product Reference Documentation](#).



NOTE: The illustrations shown below are for demonstration purposes only. Make sure to cut holes at suitable locations per wire routing proposed in the site drawings.

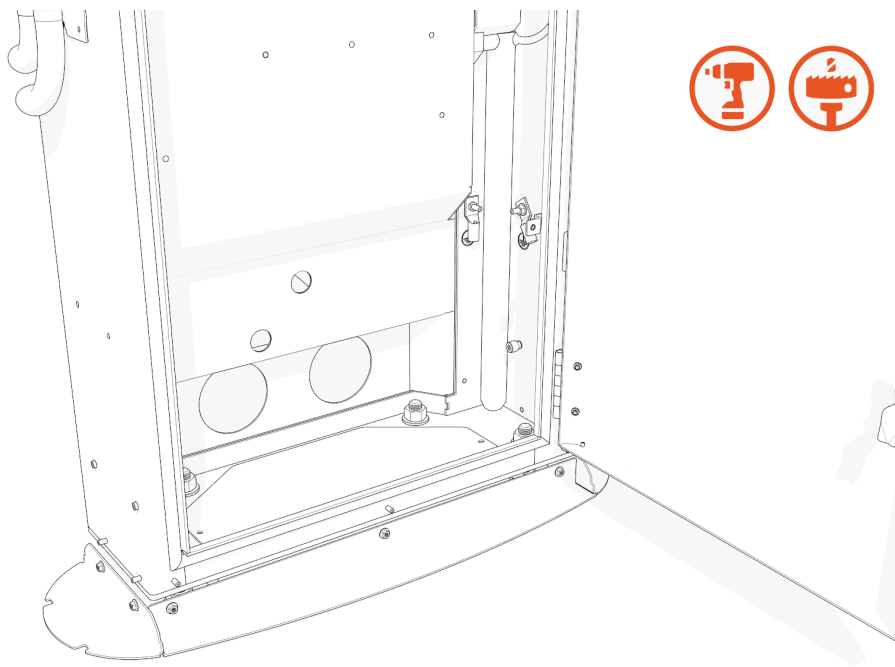

4. Cut corresponding conduit entry locations on the mounting bracket.

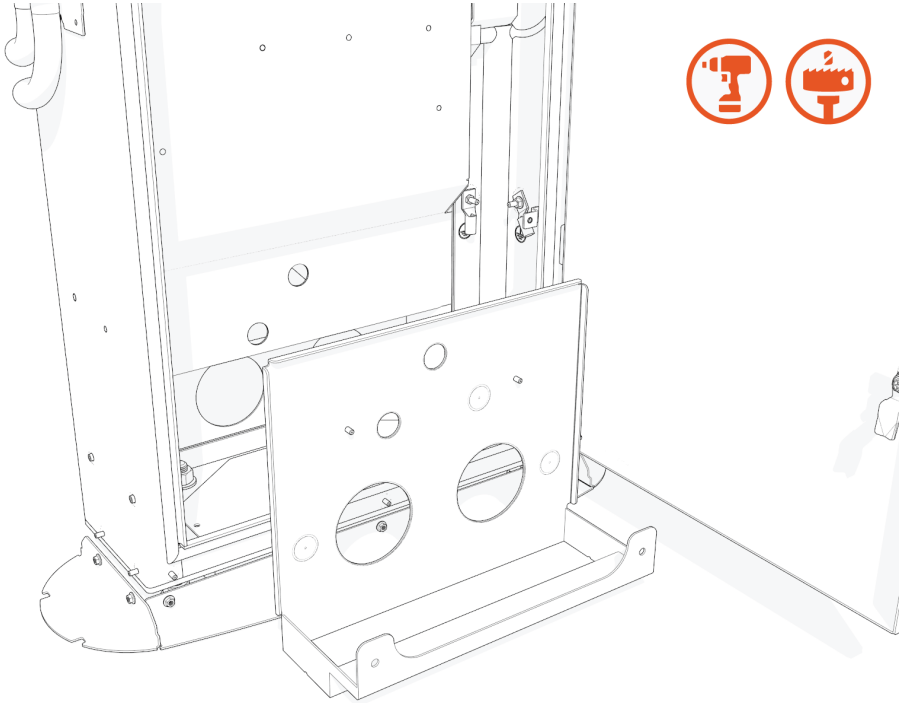

5. Vacuum all metal shavings.

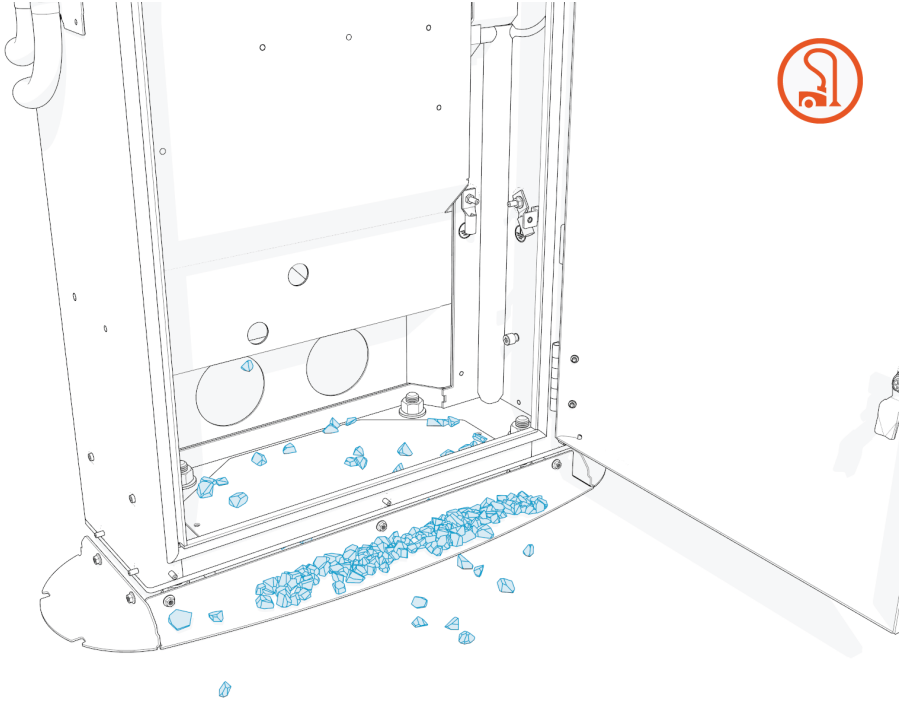

6. Align and install mounting bracket on the back of Power Link 2000. Torque the nuts (x4) to **4.5 Nm (40 in-lb)**.

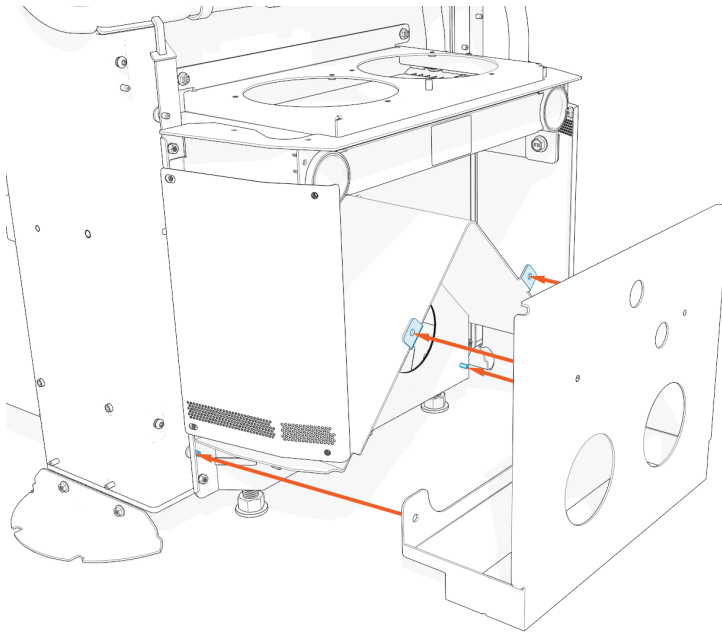

7. Install the new SCE rear lower cover.
 - a. Align and seat cover onto the alignment pins (x2) on the frame.

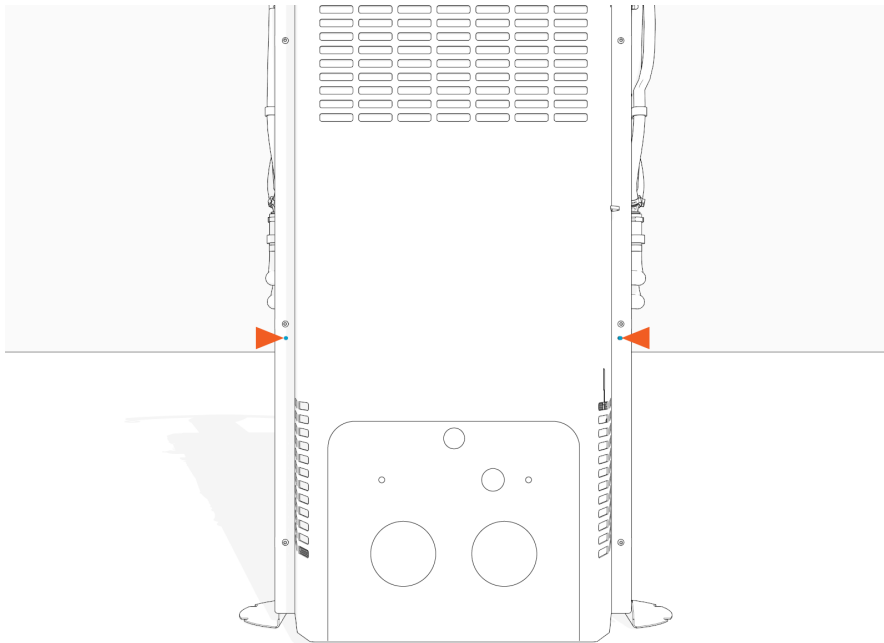

- b. Torque the screws (x6) to **4.5 Nm (40 in-lb)**.

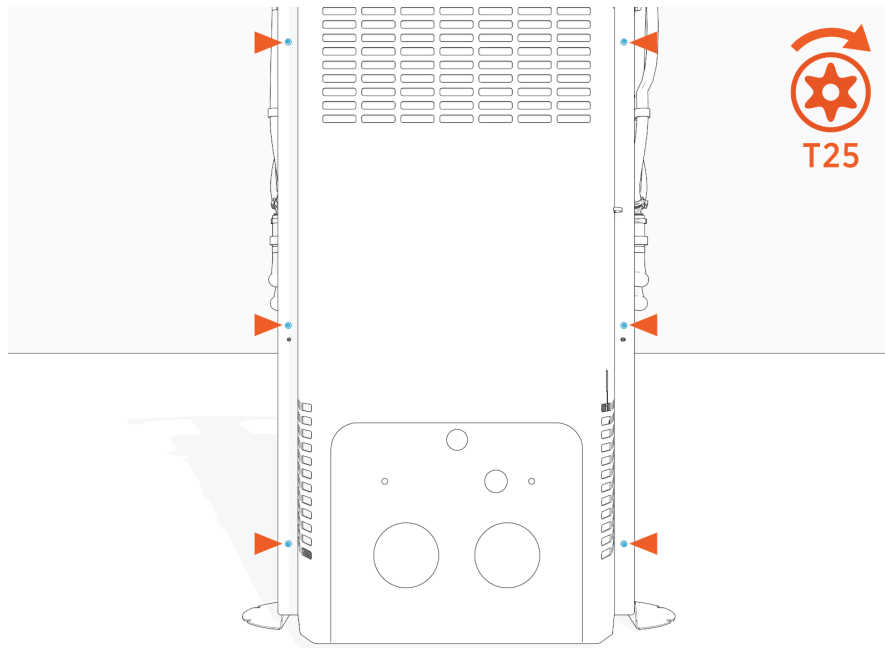

8. Install LB type conduit bodies and/or conduits into the holes.



IMPORTANT: Leave 25 mm (1 in) of clearance between the conduit bodies and the SCE rear lower cover so that the cover can be removed for service without impacting the conduit bodies.

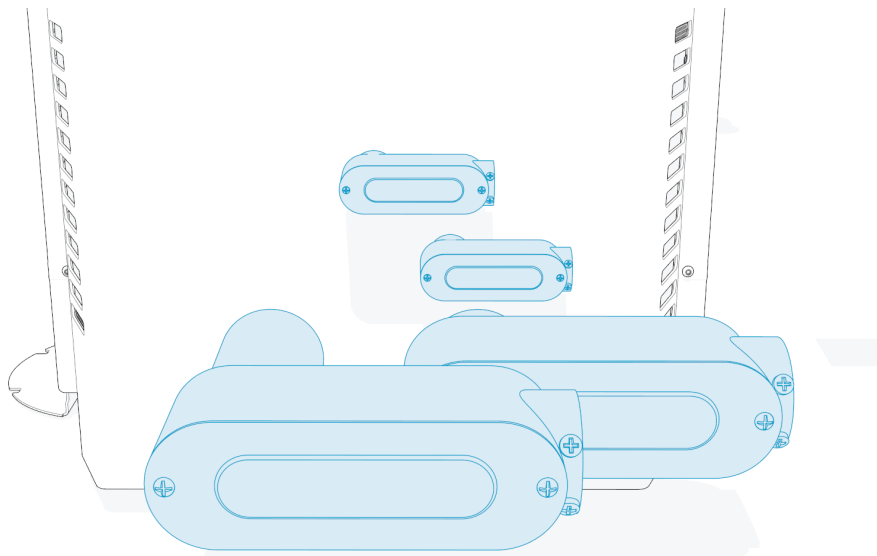

9. Install the remaining components, such as DC power path wires, charging cables, cable management kit (CMK), and covers, and complete the installation (see [Contents](#)).

Install Surface Conduits (Non-LCC)

Skip this entire procedure for LCC variant of Power Link 2000.



IMPORTANT: Refer to the site drawings and determine from which side of the Power Link 2000 the wires must enter from.

1. Open the lower enclosure door.
2. Install the gland plate.
3. Align and hold template against the rear lower cover.

IMPORTANT:



- Ensure that the template is fully laid and is centered on the rear lower cover.
- The pilot holes marked DC IN are for cutting conduit holes for DC power path wires and the ones marked LV are for 48 V DC input wires and Ethernet cable.

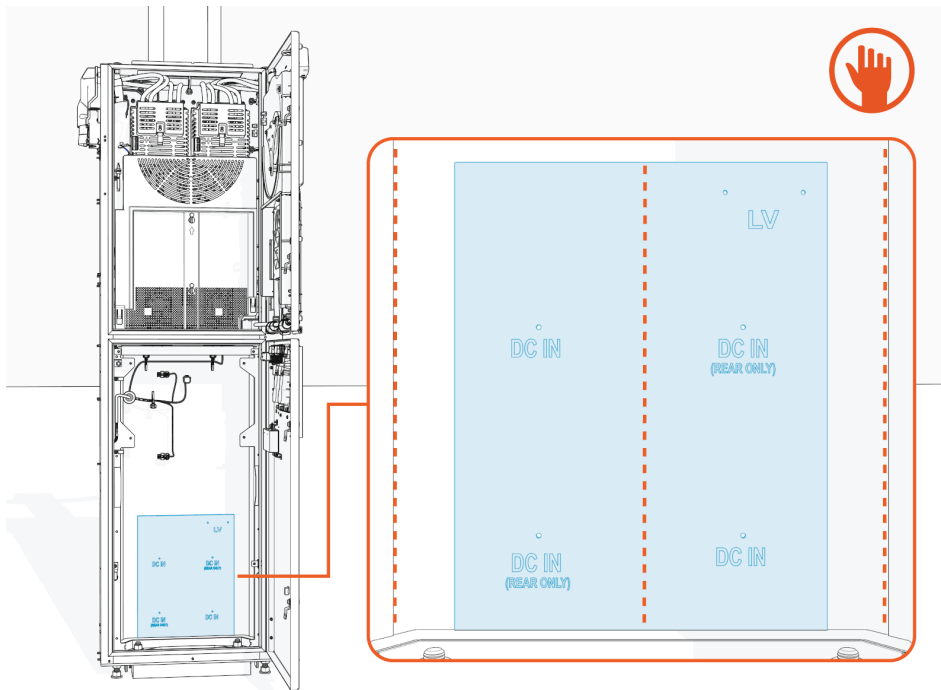

4. Mark pilot hole locations on the rear lower cover and remove the template.

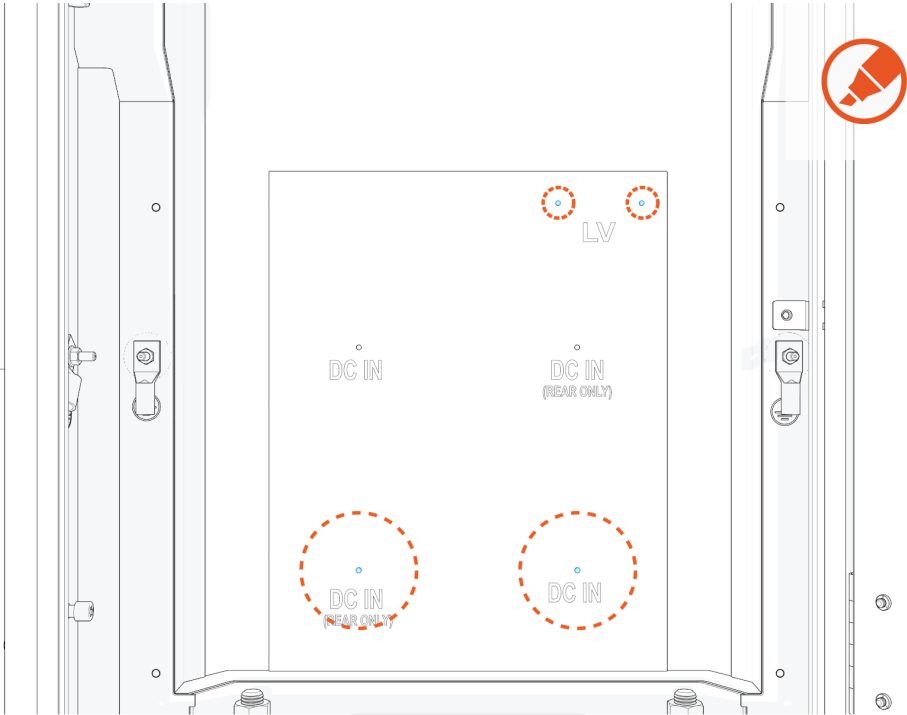

- Using a suitable hole saw, position the hole saw's pilot drill bit on the marked location, and cut a hole into the rear lower cover. Repeat for other marked locations.



IMPORTANT: To cut holes to correct size, refer to the site drawings for the actual conduit dimensions. For the maximum conduit size supported by the Power Link 2000, refer to the *Express Distro Power Link 2000 Site Design Guide*, available at [ChargePoint Product Reference Documentation](#).

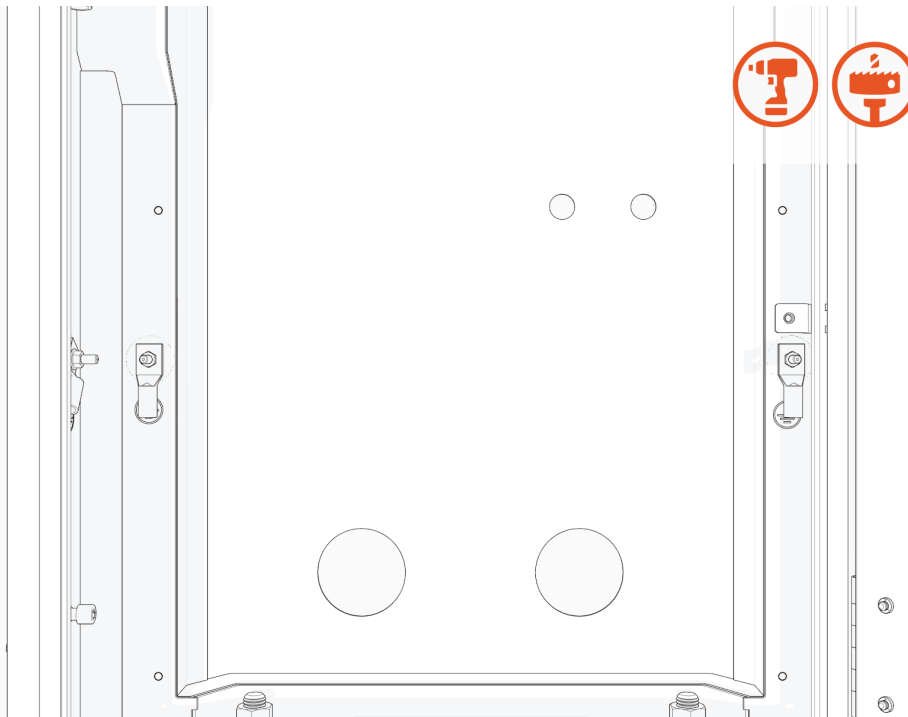

6. Vacuum all metal shavings.

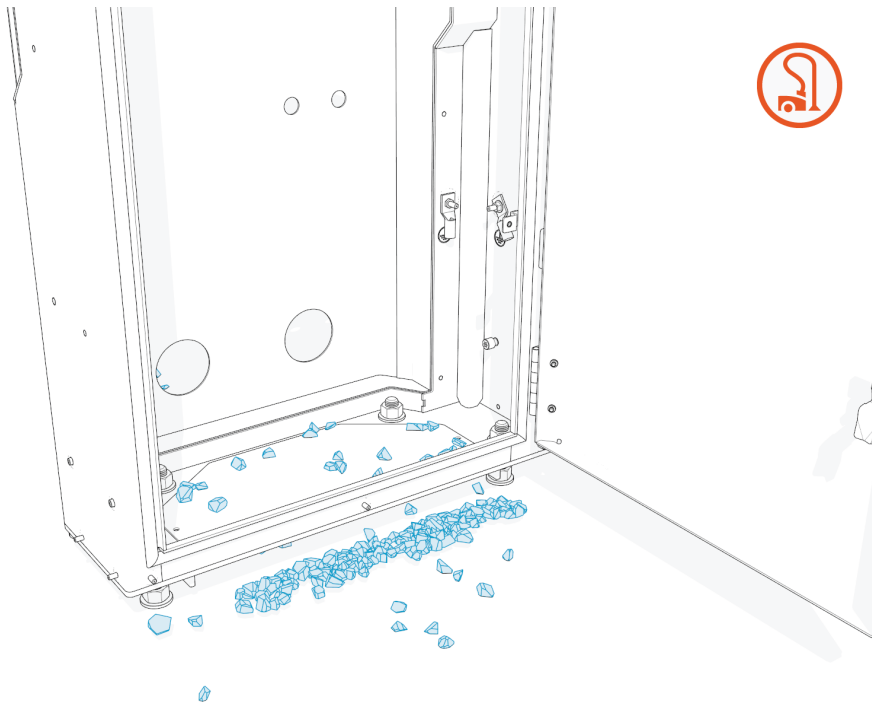

7. Install LB type conduit bodies and/or conduits into the holes.

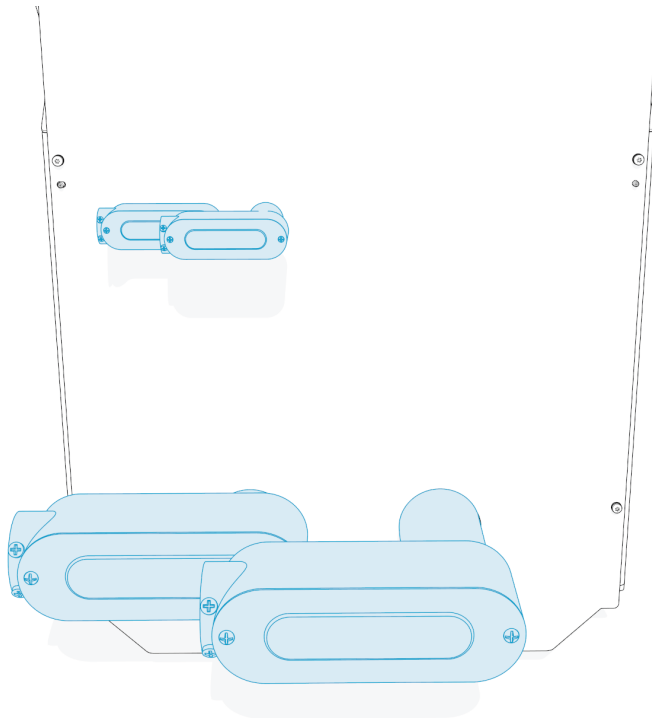

8. Install the remaining components, such as DC power path wires, charging cables, cable management kit (CMK), and covers, and complete the installation (see [Contents](#)).

Appendix: Set Up Power Link B 2000

To set up Power Link 2000, complete the following steps:



IMPORTANT: Do not power on Power Link 2000 immediately after completing the installation (after installing the covers). An Authorized Commissioning Partner must commission the Power Link 2000 after installation and before power on. The Authorized Commissioning Partner will pinpoint and configure the Power Link 2000.

Power On



NOTE: Power Link 2000 must pass commissioning before power on, or warranty limitations apply.

1. Ensure all doors and panels, covers, vinyl signs, and all other parts have been correctly installed and the work is complete.
2. Turn on power at the same points that you turned it off.



NOTE: If the site has a remote shunt trip switch, ensure that the switch is in the operating position.

- Wait for self-diagnostics to run. The system may take several minutes to initiate. You may see messages intermittently until the system fully boots up.





Self-Diagnostic	After Installation	After Service or Power Outage
Electrical safety checks	✓	✓
Lighting checks	✓	✓
Display panel checks	✓	✓
Component operation checks	✓	✓
Network connectivity checks	✓	✓
Installation Wizard (for the installer to complete configuration and pinpoint the station on maps)	✓	—

Set Up Power Link 2000

After you power on the charging station at the breaker panel, set up Power Link 2000. To do so, you need:

- ChargePoint installer login credentials.
- Activation label (QR code label including the MAC address and activation password).
- The exact location (to the parking space) where the Power Link 2000 is installed.
- A smartphone with ChargePoint Installer app, Internet connectivity, and QR code scanner (usually built into the camera app).

Scan the QR code to download the ChargePoint Installer app and sign up if necessary.

Region (Language)	QR Code	Region	QR Code
United States		France	
Canada (French)		Germany	
United Kingdom			

Follow the steps below to set up Power Link 2000:

1. Open the ChargePoint Installer app and log in.
2. Follow the onscreen prompts.



NOTE: To connect to Power Link 2000 and complete setup, you need to scan the QR code provided on the Power Link 2000 display or manually enter the MAC address and password of Power Link 2000.

Limited Warranty Information and Disclaimer

The Limited Warranty you received with your charging station is subject to certain exceptions and exclusions. For example, your use of, installation of, or modification to, the ChargePoint® charging station in a manner in which the ChargePoint® charging station is not intended to be used or modified will void the limited warranty. You should review your limited warranty and become familiar with the terms thereof. Other than any such limited warranty, the ChargePoint products are provided "AS IS," and ChargePoint, Inc. and its distributors expressly disclaim all implied warranties, including any warranty of design, merchantability, fitness for a particular purposes and non-infringement, to the maximum extent permitted by law.

Limitation of Liability

CHARGEPOINT IS NOT LIABLE FOR ANY DIRECT, INDIRECT, INCIDENTAL, SPECIAL, PUNITIVE OR CONSEQUENTIAL DAMAGES, INCLUDING WITHOUT LIMITATION LOST PROFITS, LOST BUSINESS, LOST DATA, LOSS OF USE, OR COST OF COVER INCURRED BY YOU ARISING OUT OF OR RELATED TO YOUR PURCHASE OR USE OF, OR INABILITY TO USE, THE CHARGING STATION, UNDER ANY THEORY OF LIABILITY, WHETHER IN AN ACTION IN CONTRACT, STRICT LIABILITY, TORT (INCLUDING NEGLIGENCE) OR OTHER LEGAL OR EQUITABLE THEORY, EVEN IF CHARGEPOINT KNEW OR SHOULD HAVE KNOWN OF THE POSSIBILITY OF SUCH DAMAGES. IN ANY EVENT, THE CUMULATIVE LIABILITY OF CHARGEPOINT FOR ALL CLAIMS WHATSOEVER RELATED TO THE CHARGING STATION WILL NOT EXCEED THE PRICE YOU PAID FOR THE CHARGING STATION. THE LIMITATIONS SET FORTH HEREIN ARE INTENDED TO LIMIT THE LIABILITY OF CHARGEPOINT AND SHALL APPLY NOTWITHSTANDING ANY FAILURE OF ESSENTIAL PURPOSE OF ANY LIMITED REMEDY.

FCC Compliance Statement

This equipment has been tested and found to comply with the limits for a Class B digital device, pursuant to part 15 of the FCC Rules. These limits are designed to provide reasonable protection against harmful interference when the equipment is operated in a residential installation. This equipment generates, uses, and can radiate radio frequency energy and, if not installed and used in accordance with the instruction manual, may cause harmful interference to radio communications.

Important: Changes or modifications to this product not authorized by ChargePoint, inc., could affect the EMC compliance and revoke your authority to operate this product.

Exposure to Radio Frequency Energy: The radiated power output of the 802.11 b/g/n radio and cellular modem (optional) in this device is below the FCC radio frequency exposure limits for uncontrolled equipment. The antenna of this product, used under normal conditions, is at least 20 cm away from the body of the user. This device must not be co-located or operated with any other antenna or transmitter by the manufacturer, subject to the conditions of the FCC Grant.

ISED (formerly Industry Canada)

This device complies with the licence-exempt RSS standard(s) of Innovation, Science and Economic Development Canada (ISED). Operation is subject to the following two conditions: (1) this device may not cause interference, and (2) this device must accept any interference, including interference that may cause undesired operation of the device.

Cet appareil est conforme aux flux RSS exemptés de licence d'Innovation, Sciences et Développement économique Canada (ISDE). L'exploitation est autorisée aux deux conditions suivantes : (1) l'appareil ne doit pas produire de brouillage, et (2) l'utilisateur de l'appareil doit accepter.

Radiation Exposure Statement: This equipment complies with the IC RSS-102 radiation exposure limits set forth for an uncontrolled environment. This equipment should be installed and operated with a minimum distance of 20 cm between the radiator and your body.

Énoncé d'exposition aux rayonnements: Cet équipement est conforme aux limites d'exposition aux rayonnements ioniques RSS-102 Pour un environnement incontrôlé. Cet équipement doit être installé et utilisé avec un Distance minimale de 20 cm entre le radiateur et votre corps.

FCC/IC Compliance Labels

Visit chargepoint.com/labels.